

## 8" Wet Sharpener



## Operator's Manual

Record the serial number and date of purchase in your manual for future reference.

The serial number can be found on the specification label on the rear of your machine.

Serial Number: \_\_\_\_\_ Date of purchase: \_\_\_\_\_

For technical support or parts questions, email [techsupport@rikontools.com](mailto:techsupport@rikontools.com) or call toll free at (877)884-5167

# TABLE OF CONTENTS

Specifications.....	2
Safety Instructions.....	3-7
Electrical Safety.....	6-7
Carton Contents.....	8
Machine Overview.....	9
Assembly Instructions.....	10-12
Operation.....	11-14
Maintenance.....	14
Wiring Diagram.....	15
Notes.....	15
Parts Diagram.....	16
Parts List.....	17
Troubleshooting.....	18
Warranty.....	19

## SPECIFICATIONS

MOTOR POWER .....	1/4HP, 120V, 1.6A, 60Hz
MOTOR SPEED (no load) .....	1750 RPM
WHEEL SPEED (no load) .....	115 RPM
MOTOR ARBOR .....	1/2" (12MM)
WET WHEEL SIZE .....	8" Dia. x 1-9/16" Wide
WET WHEEL .....	Vitrified Aluminum Oxide, 220 Grit
STROP WHEEL SIZE .....	8" Dia. x 1-1/8" Wide
ON/OFF SWITCH (bilateral) .....	Reverse-On/ Off / Forward-On
POWER CORD .....	6 Feet
WEIGHT .....	GW 26 lbs. / NW 23 lbs.
GRINDER BASE (WxD) .....	11-1/2" x 10"
MOUNTING HOLES (2) .....	7/16" Dia., 10-1/2" Apart
OVERALL SIZE Approx. (LxWxH) .....	17" x 10" x 12"

**This owner's manual is not a teaching aid and is intended to show assembly, adjustments, and general use.**

**NOTE:** The specifications, photographs, drawings and information in this manual represent the current machine model when the manual was prepared. Changes and improvements may be made at any time, with no obligation on the part of Rikon Power Tools to modify previously delivered units. Reasonable care has been taken to ensure that the information in this manual is correct, to provide you with the guidelines for the proper safety, assembly and operation of this machine.

# SAFETY INSTRUCTIONS

## SAVE THESE INSTRUCTIONS Refer to them often.

### GENERAL SAFETY

Operating machinery can be dangerous if safety and common sense are ignored. The user must be familiar with the operation of the tool. Read this manual to understand this Wet Sharpener. **DO NOT** operate this machine if you do not fully understand the limitations of this tool. **DO NOT** modify this Wet Sharpener in any way.

### BEFORE USING THE SHARPENER

#### **WARNING:**

To avoid serious injury and damage to the tool, read and follow all of the Safety and Operating Instructions before operating the Wet Sharpener.

#### **WARNING:**

1. Some dust created by using power tools contains chemicals known to the State of California to cause cancer, birth defects, or other reproductive harm.

Some examples of these chemicals are:

- Lead from lead-based paints.
- Crystalline silica from bricks, cement, and other masonry products.
- Arsenic and chromium from chemically treated lumber.

Your risk from these exposures varies, depending on how often you do this type of work. To reduce your exposure to these chemicals: work in a well ventilated area and work with approved safety equipment, such as those dust masks that are specially designed to filter out microscopic particles.

2. **READ** the entire Owner's Manual. **LEARN** how to use the tool for its intended applications.

3. **GROUND ALL TOOLS.** If the tool is supplied with a 3-prong plug, it must be plugged into a 3-contact electrical receptacle. The 3rd prong is used to ground the tool and provide protection against accidental electric shock. **DO NOT** remove the 3rd prong. See Grounding Instructions on page 7.

4. **AVOID A DANGEROUS WORKING ENVIRONMENT.** **DO NOT** use electrical tools in a damp environment or expose them to rain.

5. **DO NOT** use electrical tools in the presence of flammable liquids or gasses.

6. **ALWAYS** keep the work area clean, well lit, and organized. **DO NOT** work in an environment with floor surfaces that are slippery from debris, grease, and wax.

7. **KEEP VISITORS AND CHILDREN AWAY.** **DO NOT** permit people to be in the immediate work area, especially when the electrical tool is operating.

8. **DO NOT FORCE THE TOOL** to perform an operation for which it was not designed. It will do a safer and higher quality job by only performing operations for which the tool was intended.

9. **WEAR PROPER CLOTHING.** **DO NOT** wear loose clothing, gloves, neckties, or jewelry. These items can get caught in the machine during operations and pull the operator into the moving parts. The user must wear a protective cover on their hair, if the hair is long, to prevent it from contacting any moving parts.

10. **CHILDPROOF THE WORKSHOP AREA** by removing switch keys, unplugging tools from the electrical receptacles, and using padlocks.

11. **ALWAYS UNPLUG THE TOOL FROM THE ELECTRICAL RECEPTACLE** when making adjustments, changing parts or performing any maintenance.

12. **KEEP PROTECTIVE GUARDS IN PLACE AND IN WORKING ORDER.**

13. **AVOID ACCIDENTAL STARTING.** Make sure that the power switch is in the "OFF" position before plugging in the power cord to the electrical receptacle.

# SAFETY INSTRUCTIONS

**14. REMOVE ALL MAINTENANCE TOOLS** from the immediate area prior to turning "ON" the machine.

**15. USE ONLY RECOMMENDED ACCESSORIES.** Use of incorrect or improper accessories could cause serious injury to the operator and cause damage to the tool. If in doubt, check the instruction manual that comes with that particular accessory.

**16. NEVER LEAVE A RUNNING TOOL UNATTENDED.** Turn the power switch to the "OFF" position. **DO NOT** leave the tool until it has come to a complete stop.

**17. DO NOT STAND ON A TOOL.** Serious injury could result if the tool tips over, or you accidentally contact the tool.

**18. DO NOT** store anything above or near the tool where anyone might try to stand on the tool to reach it.

**19. MAINTAIN YOUR BALANCE. DO NOT** extend yourself over the tool. Wear oil resistant rubber soled shoes. Keep floor clear of debris, grease, and wax.

**20. MAINTAIN TOOLS WITH CARE.** Always keep tools clean and in good working order. Keep all blades and tool bits sharp, dress grinding wheels and change other abrasive accessories when worn.

**21. EACH AND EVERY TIME, CHECK FOR DAMAGED PARTS PRIOR TO USING THE TOOL.** Carefully check all guards to see that they operate properly, are not damaged, and perform their intended functions. Check for alignment, binding or breaking of moving parts. A guard or other part that is damaged should be immediately repaired or replaced.

**22. DO NOT OPERATE TOOL WHILE TIRED, OR UNDER THE INFLUENCE OF DRUGS, MEDICATION OR ALCOHOL.**

**23. SECURE ALL WORK.** Use clamps or jigs to secure the work piece. This is safer than attempting to hold the work piece with your hands.

**24. STAY ALERT, WATCH WHAT YOU ARE DOING, AND USE COMMON SENSE WHEN OPERATING A POWER TOOL.**

A moment of inattention while operating power tools may result in serious personal injury.

**25. ALWAYS WEAR A DUST MASK TO PREVENT INHALING DANGEROUS DUST OR AIRBORNE PARTICLES,** including wood dust, crystalline silica dust and asbestos dust.

Direct particles away from face and body.

Always operate tool in well ventilated area and provide for proper dust removal.

Use dust collection system wherever possible.

Exposure to the dust may cause serious and permanent respiratory or other injury, including silicosis (a serious lung disease), cancer, and death.

Avoid breathing the dust, and avoid prolonged contact with dust. Allowing dust to get into your mouth or eyes, or lay on your skin may promote absorption of harmful material.

Always use properly fitting NIOSH/OSHA approved respiratory protection appropriate for the dust exposure, and wash exposed areas with soap and water.

**26. USE A PROPER EXTENSION CORD IN GOOD CONDITION.** When using an extension cord, be sure to use one heavy enough to carry the current your product will draw.

The table on page 8 shows the correct size to use depending on cord length and nameplate amperage rating. If in doubt, use the next heavier gauge. The smaller the gauge number, the larger diameter of the extension cord. If in doubt of the proper size of an extension cord, use a shorter and thicker cord. An undersized cord will cause a drop in line voltage resulting in a loss of power and overheating.

**USE ONLY A 3-WIRE EXTENSION CORD THAT HAS A 3-PRONG GROUNDING PLUG AND A 3-POLE RECEPTACLE THAT ACCEPTS THE TOOL'S PLUG.**

**SEE PAGES 6, 7 AND 15 FOR INFORMATION ON ELECTRICALS AND WIRING OF THIS MACHINE.**

# SAFETY INSTRUCTIONS

## SPECIFIC SAFETY INSTRUCTIONS FOR THE WET SHARPENER

Basic precautions should always be followed when using your wet sharpener. To reduce the risk of injury, electrical shock, or fire, comply with the safety rules listed below:

1. The operation of any sharpener or power tool can result in debris being thrown into your eyes, which can result in severe and permanent eye damage. **ALWAYS WEAR EYE PROTECTION.** Everyday eyeglasses are **NOT** safety glasses. **ALWAYS** wear Safety Goggles (that comply with ANSI standard Z87.1) when operating power tools. Using a respirator is also recommended
2. **DO NOT** operate this machine until it is completely assembled and installed according to the instructions. A machine incorrectly assembled can cause serious injury.
3. **FOLLOW ALL WIRING CODES** and recommended electrical connections to prevent shock or electrocution.
4. **SECURE THE BENCH GRINDER** to a stand or workbench to prevent sliding or tipping during start up or use. See page 14.
5. **INSPECT WHEELS** for cracks or fragments before starting the machine . **REPLACE DAMAGED WHEELS** immediately. Parts of the wheel can be thrown at high speeds causing injury.
6. **REPLACE A CRACKED OR DAMAGED GRINDING WHEEL IMMEDIATELY.** A damaged wheel can discharge debris at a high velocity towards the operator. Carefully handle the grinding wheels since they are abrasive. Prior to replacing a grinding wheel, check it for cracks. **DO NOT** remove the blotter or label on both sides of the grinding wheel. Tighten the spindle nut just enough to hold the grinding wheel firmly to the Grinder. **DO NOT** over-tighten the nut. Excessive clamping force can damage the grinding wheel. Only use the wheel flanges provided with the grinder. Use only properly sized wheels (diameter, width and bore) and verify that the grinding wheel has a higher R.P.M. rating than the maximum R.P.M. of the machine.
7. **DO NOT USE A WHEEL THAT VIBRATES.** Dress the grinding wheel, replace it, or replace the bearings of the shaft. Unsuitable grinding wheels can come apart, throwing fragments that may cause injury to you or the machine.
8. **THE DIAMETER OF THE GRINDING WHEELS WILL DECREASE WITH USE.** Adjust the tool rests and any jigs to maintain a safe distance of 1/8" or less from the wheel.
9. **DO NOT STAND IN FRONT OF THE BENCH GRINDER WHEN STARTING IT.** Stand to one side of the Grinder and turn it "ON". Wait at the side until the grinder comes up to full speed. There is always a possibility that debris from a damaged grinding wheel may be discharged towards the operator.
10. **ALLOW THE GRINDER TO ATTAIN FULL SPEED BEFORE BEGINNING WORK.**
11. **NEVER START THE MACHINE with the workpiece against the grinding wheel.** The workpiece can be drawn into the wheel, causing damage to the machine and/or serious injury.
12. **NEVER GRIND ON A COLD WHEEL.** Run the sharpener for one full minute before applying the workpiece. A cold wheel has a tendency to chip. Those fragments could fly from the wheel at high speeds.
13. **NEVER FORCE THE WORK PIECE AGAINST A GRINDING WHEEL,** especially if the wheel is cold. Apply the work piece slowly, allowing the grinding wheel an opportunity to warm up. This will minimize the chance of wheel breakage.
14. **GRIND A WORKPIECE** using the face of the grinding wheel only. **DO NOT** grind using the sides of the grinding wheels. Damage to the wheel and a loss of control of the workpiece can cause serious injury.
15. **NEVER GRIND NEAR FLAMMABLE GAS OR LIQUIDS.** Sparks can create a fire or an explosion.
16. **KEEP THE TOOL RESTS FIRMLY IN PLACE AND TIGHTENED.** Use them along with any tool-holding jigs to safely hold and position your material for grinding.

# SAFETY INSTRUCTIONS

17. **CLEAN THE MACHINE** thoroughly when processing different types of workpieces (steel, aluminum, etc.). Combining metal and wood dust can create an explosion or fire hazard. **DO NOT GRIND** or polish magnesium. Fire will result.

18. **ALWAYS USE a tool rest or tool-holding jigs**, and grasp the workpiece firmly with both hands when grinding. Loss of control of the workpiece can cause serious injury. **AVOID** awkward operations and hand positions. A sudden slip could cause a hand to move into the grinding wheel. The abrasive surfaces can cause injury.

19. **PROPERLY SUPPORT LONG OR WIDE** workpieces. Loss of control of the workpiece can cause serious injury.

20. **NEVER GRIND SMALL STOCK** without it being properly supported on the tool rests, and held by pliers or clamps.

21. **DO NOT TOUCH** the ground portion of a workpiece until it has cooled sufficiently. Grinding creates heat and may burn you if touched.

22. **DO NOT FORCE THE TOOL** to perform an operation for which it was not designed. It will do a safer and higher quality job by only performing operations for which the tool was intended.

23. **DRESS THE GRINDING WHEEL OFTEN.** This will keep the wheel surface flat and free of nicks and residue/glaze. **RESURFACE ONLY THE FACE OF THE GRINDING WHEEL.** Dressing the side of the wheel could cause it to become too thin for safe use.

24. **NEVER STOP THE GRINDER BY FORCING MATERIAL INTO THE WHEEL.** Let the grinder stop rotating on its own.

25. **TURN THE MACHINE OFF**, disconnect the machine from the power source, empty the water from the tray so that the stone will not rest in the water for long periods which can weaken the bonding strength of the grinding wheel and cause it to fail, and clean the table/work area before leaving the machine.

18. **ADDITIONAL INFORMATION** regarding the safe and proper operation of grinders is available from:

- Power Tool Institute  
1300 Summer Avenue  
Cleveland, OH 44115-2851  
[www.powertoolinstitute.org](http://www.powertoolinstitute.org)
- National Safety Council  
1121 Spring Lake Drive  
Itasca, IL 60143-3201  
[www.nsc.org](http://www.nsc.org)
- American National Standards Institute  
25 West 43rd Street, 4th Floor  
New York, NY 10036  
[www.ansi.org](http://www.ansi.org)
- ANSI 01.1 Safety Requirements for Woodworking Machines and the U.S. Department of Labor regulations  
[www.osha.gov](http://www.osha.gov)

19. **SAVE THESE INSTRUCTIONS.** Refer to them frequently and use them to instruct others.

---

## ELECTRICAL SAFETY



**WARNING:** THIS TOOL MUST BE GROUNDED WHILE IN USE TO PROTECT THE OPERATOR FROM ELECTRIC SHOCK.

**IN THE EVENT OF A MALFUNCTION OR BREAKDOWN**, grounding provides the path of least resistance for electric current and reduces the risk of electric shock. This tool is equipped with an electric cord that has an equipment grounding conductor and a grounding plug. The plug **MUST** be plugged into a matching electrical

receptacle that is properly installed and grounded in accordance with **ALL** local codes and ordinances.

**DO NOT MODIFY THE PLUG PROVIDED.**

If it will not fit the electrical receptacle, have the proper electrical receptacle installed by a qualified electrician.

**IMPROPER ELECTRICAL CONNECTION** of the equipment grounding conductor can result in risk of electric shock. The conductor with the green insulation (with or without yellow stripes) is the equipment grounding conductor. **DO NOT**

# SAFETY INSTRUCTIONS

connect the equipment grounding conductor to a live terminal if repair or replacement of the electric cord or plug is necessary.

**CHECK** with a qualified electrician or service personnel if you do not completely understand the grounding instructions, or if you are not sure the tool is properly grounded.

**USE ONLY A 3-WIRE EXTENSION CORD THAT HAS A 3-PRONG GROUNDING PLUG AND A 3-POLE RECEPTACLE THAT ACCEPTS THE TOOL'S PLUG. REPLACE A DAMAGED OR WORN CORD IMMEDIATELY.**

This tool is intended for use on a 120V circuit that has an electrical receptacle as shown in **FIGURE A**. It shows a 3-wire electrical plug and receptacle that has a grounding conductor. If a properly grounded electrical receptacle is not available, an adapter, as shown in **FIG. B**, can be used to temporarily connect this plug to a 2-contact ungrounded receptacle. The adapter has a rigid lug extending from it that **MUST** be connected to a permanent earth ground, such as a properly grounded receptacle box. **THIS ADAPTER IS PROHIBITED IN CANADA.**

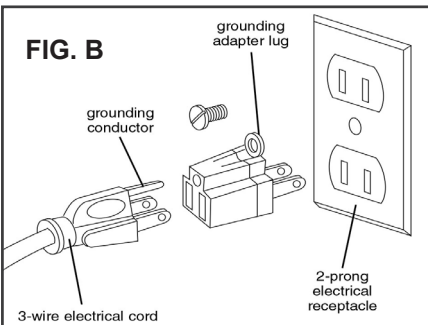
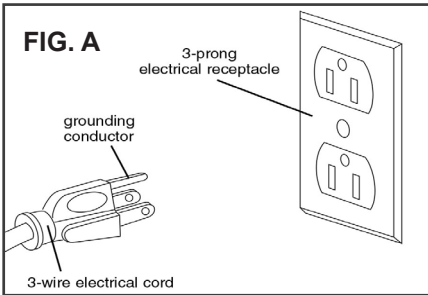

## EXTENSION CORDS

**WARNING:** Keep the extension cord clear of the working area. Position the cord so that it will not get caught on lumber, tools or other obstructions while you are working with a power tool.

**WARNING:** Check extension cords before each use. If damaged replace immediately. Never use a tool with a damaged cord, since touching the damaged area could cause electrical shock, resulting in serious injury.

Use a proper extension cord. Only use cords listed by Underwriters Laboratories (UL). Other extension cords can cause a drop in line voltage, resulting in a loss of power and overheating of tool. When operating a power tool outdoors, use an outdoor extension cord marked "W-A" or "W". These cords are rated for outdoor use and reduce the risk of electric shock.

### MINIMUM RECOMMENDED GAUGE FOR EXTENSION CORDS (AWG)

120 VOLT OPERATION ONLY				
	25' LONG	50' LONG	100' LONG	150' LONG
0 to 6 Amps	18 AWG	16 AWG	16 AWG	14 AWG
6 to 10 Amps	18 AWG	16 AWG	14 AWG	12 AWG
10 to 12 Amps	16 AWG	16 AWG	14 AWG	12 AWG

**WARNING:** THE MACHINE MUST NOT BE PLUGGED IN AND THE POWER SWITCH MUST BE IN THE OFF POSITION UNTIL ASSEMBLY OF THE PARTS AND ALL ADJUSTMENTS ARE COMPLETE.

See page 15 for the Wet Sharpener's wiring diagram

# CARTON CONTENTS

## UNPACKING AND CHECKING CONTENTS

1. Report any shipping damage to your local distributor. Take photographs for any possible insurance claims.
2. Remove parts from all of the cartons and lay them on a clean work surface.
3. Remove any protective materials and coatings from all of the parts and the bench grinder. The protective coatings can be removed by spraying WD-40 on them and wiping it off with a soft cloth. This may need to be redone several times before all of the protective coatings are removed completely.

**CAUTION: DO NOT** use acetone, gasoline or lacquer thinner to remove any protective coatings.

4. Compare the items to Figure 1; verify that all items are accounted for before discarding the shipping box.

**WARNING:**

If any parts are missing, do not attempt to plug in the power cord and turn "ON" the machine. The Sharpener can only be turned "ON" after all the parts have been obtained and installed correctly.

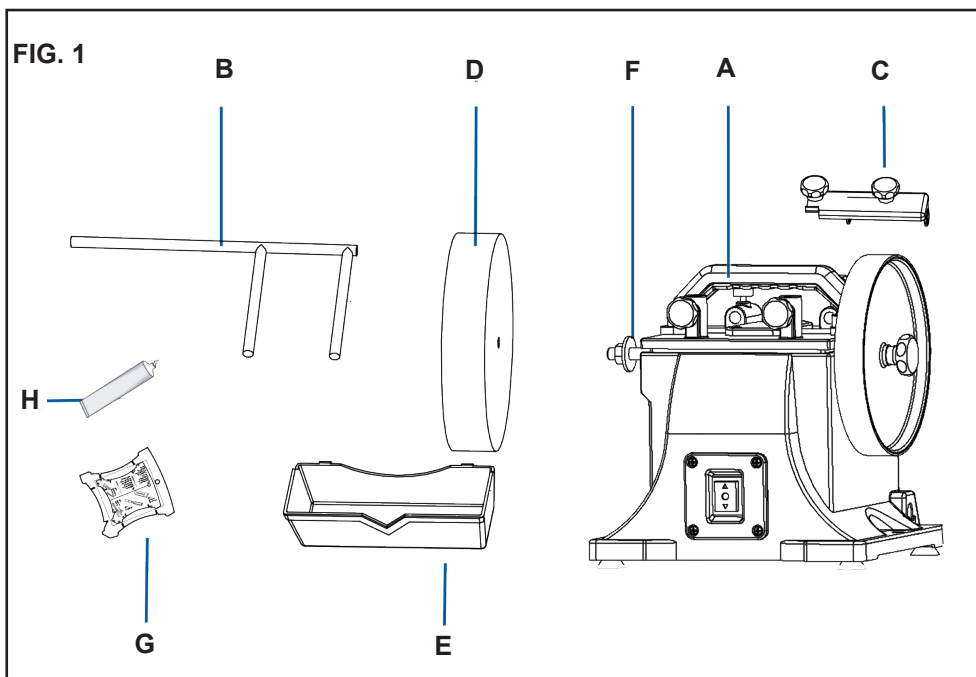

The following items are provided in the shipping box:

- |   |                     |
|---|---------------------|
| A. Sharpener and 4 knobs for the tool rest mounts | E. Water Reservoir  |
| B. Universal 'F' Support Tool Rest                | F. Bolt Flat Washer |
| C. Tool Holder Jig                                | G. Angle Guide      |
| D. Wet Grinding Wheel                             | H. Honing Compound  |

**NOTE:** Full Parts Diagram and Parts List are listed on pages 16 and 17.



# MACHINE OVERVIEW

## 82-100 8" WET SHARPENER OVERVIEW

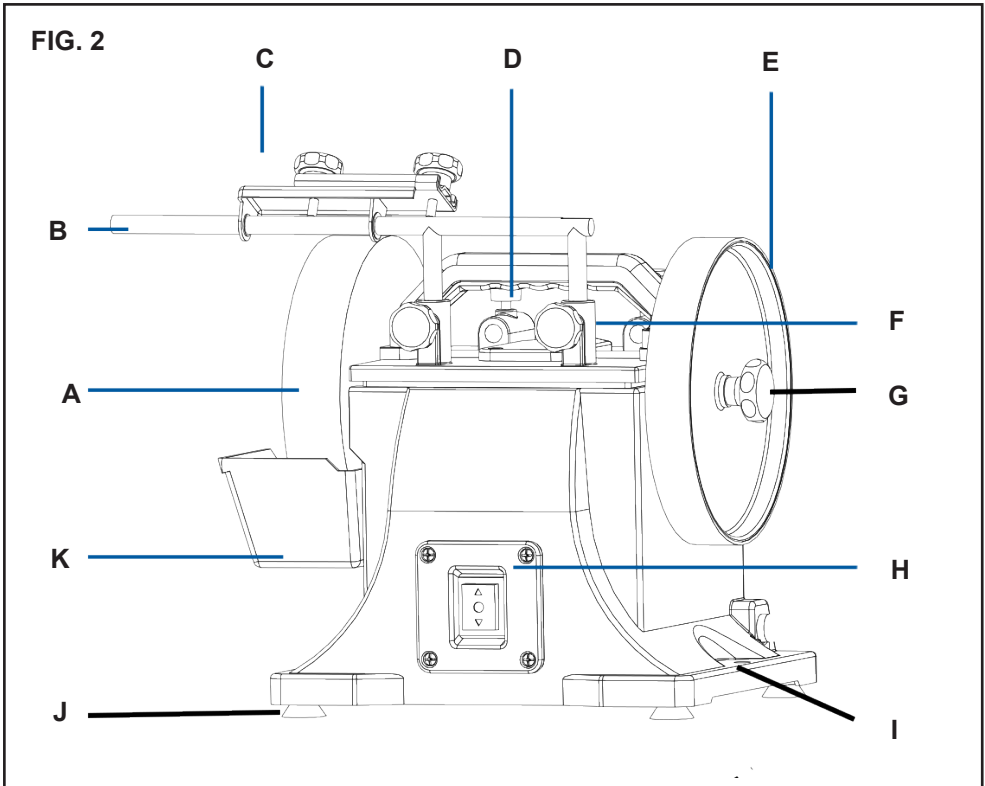

- |                                    |                                       |
|------------------------------------|---------------------------------------|
| A. 8" Wet Grinding Wheel, 220 Grit | G. Wheel Lock Knob                    |
| B. Universal 'F' Support Tool Rest | H. On/Off Switch with Forward/Reverse |
| C. Tool Holder Jig                 | I. Mounting Hole                      |
| D. Horizontal Mounts with Knobs    | J. Rubber Feet                        |
| E. Leather Stropping Wheel         | K. Water Reservoir                    |
| F. Vertical Mounts with Knobs      |                                       |

**NOTE:** Full Parts Explosion and Parts List are listed on pages 16 and 17.



**WARNING:** THE MACHINE MUST NOT BE PLUGGED IN AND THE POWER SWITCH MUST BE IN THE OFF POSITION UNTIL ASSEMBLY OF THE PARTS AND ALL ADJUSTMENTS ARE COMPLETE.

# ASSEMBLY

## PLACEMENT & PREPARATION

See Figure 3 for the minimum working clearance in the set-up shown. Remember that the sharpener has no specific front or back side and must be repositioned depending on the desired grinding/sharpening/honing action.

## MOUNT THE WET STONE

The sharpener is shipped with the Wet Stone off of the machine. Make sure that the machine is not plugged in before assembling the stone onto the sharpener.

Remove the nut and outer flange from the main shaft, slide the wet stone onto the shaft, then reinstall the flange and nut to secure the stone in place.

See pages 11 - 13 for information on proper use, maintenance and storing of the stone.

## MOUNT THE WATER TANK

The Water Tank has two tabs which serve as hooks to attach it to the mounting slots that are in the machine's side, by the wet stone.

See page 12 and Figure 7 for additional information on the use of the water tank.

## POSITIONING THE UNIVERSAL SUPPORT

The wet sharpener is equipped with a universal support that serves as a tool rest and as an attachment point for the sharpener jig. It can be attached in two positions - at the front of the machine in the vertical holders, or at the rear in the horizontal holders. These positions allow for grinding with or against the rotation direction of the grinding wheel.

- The tightening knobs on each attachment point allow the universal support to be adjusted and locked in position, depending on the specific task required.
- *Working against the rotation* removes large amounts of materials quickly, but does not yield precise results. Use this method for coarse tools such as axes.
- *Working with the rotation* yields much more precise results and removes less material. Use this method for finer tools, such as knives or carving tools.

Page 10

**⚠ WARNING:** THE MACHINE MUST NOT BE PLUGGED IN AND THE POWER SWITCH MUST BE IN THE OFF POSITION UNTIL ASSEMBLY OF THE PARTS AND ALL ADJUSTMENTS ARE COMPLETE.

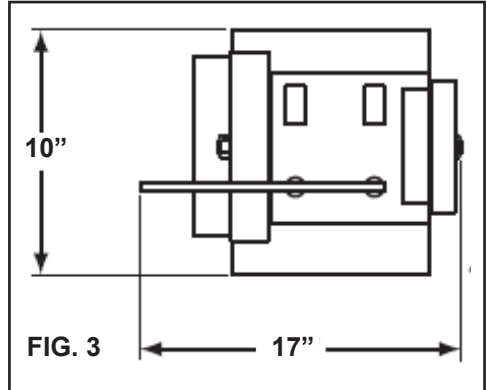

See page 14 for information on mounting the wet sharpener to a workbench or stand.

## GRINDING TIPS

- Always be sure the grinding wheel is fully wet before grinding. Have the reservoir filled with luke-warm water and attached onto the machine under the stone.
  - Wear the proper protective clothing. Safety glasses/face shield and a dust mask should be worn at all times.
  - Grasp the workpiece firmly and properly support it on the universal support or grinding jig during operation. Maintain even pressure and control of the workpiece when grinding.
  - Grind the workpiece using the face of the wheel only. **DO NOT** grind using the sides of the grinding wheels. Damage to the wheel and a loss of control of the workpiece can cause serious injury.
  - Concentrate on the task at hand. STOP grinding if other people are distracting you or your mind is on something else.
- \* See the Safety Instructions on pages 5 & 6 for vital information on proper use of the machine.

# ASSEMBLY & OPERATION

## GRINDING AGAINST WHEEL ROTATION

The sharpener has been outfitted with a power switch that permits the grinding wheel to rotate in the front/forward or the back/reverse direction.

- DISCONNECT SHARPENER FROM POWER!
- Position the machine with the ON/OFF switch facing you.
- Attach the universal support (A) in the vertical mounts (B), as shown in Figure 4. Be sure it is securely positioned and will not move during the grinding process.
- Rest your workpiece on the universal support with the sharpened edge pointing away from you. Grind your workpiece on the face of the wet wheel. Use the whole width of the stone so that the face remains flat and does not get worn in only one spot.

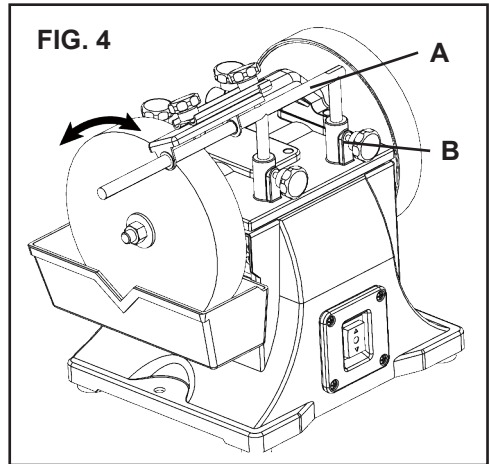

## GRINDING WITH WHEEL ROTATION

- DISCONNECT SHARPENER FROM POWER!
- Position the machine with the ON/OFF switch facing away from you.
- Attach the universal support in the horizontal mounts as shown in Figure 5. Be sure it is securely positioned and will not move during use.
- Rest your workpiece on the universal support with the sharpened edge pointing away from you. Grind your workpiece in the indicated grinding area.

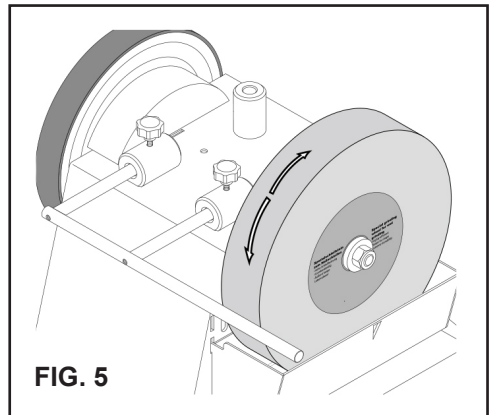

## GRINDING JIG

The grinding jig provided with the wet sharpener is used for securing a variety of tools, and can be positioned to grind with and against the wheel rotation.

To mount the grinding jig:

- DISCONNECT SHARPENER FROM POWER!
- Slide the grinding jig (A) onto the universal support (B), as illustrated in Figure 6.
- Insert the tool into the jig clamp, then use the angle guide, as described in the manual, to set the grinding angle.
- Once the grinding angle is set, tighten both lock knobs to secure the tool in place.



# ASSEMBLY & OPERATION

## WATER RESERVOIR

The wet sharpener is designed for wet grinding and should never be used without water. Before filling the water reservoir, identify the reservoir mounting slots on the machine sides (A), as shown in Figure 7. These slots allow the reservoir to be mounted during grinding and lowered when not in use. The mounting tabs on the reservoir serve as hooks to attach to the mounting slots.

To fill and position the reservoir:

- Remove the reservoir and fill it with water to just below the V-shaped notch.
- Attach the reservoir to the sharpener.
- If the sharpener is not going to be used immediately, remove the reservoir from the machine. This reduces the likelihood of damage to the wheel and potential hazards from the stone being stored in water.

Tips for using the sharpener water reservoir:

- Check the water level before every use and be sure the wheel is wet before you begin grinding. **DO NOT** use the sharpener without water.
- Leaving the grinding wheel stored in water will cause damage to the wheel and create potential hazards because the wheel will become unbalanced. Never leave the wheel in water or store it when wet if shop temperatures drop to where water freezes.
- Once any grinding process is complete, return the reservoir to the storage position to prevent prolonged water exposure to the wheel.

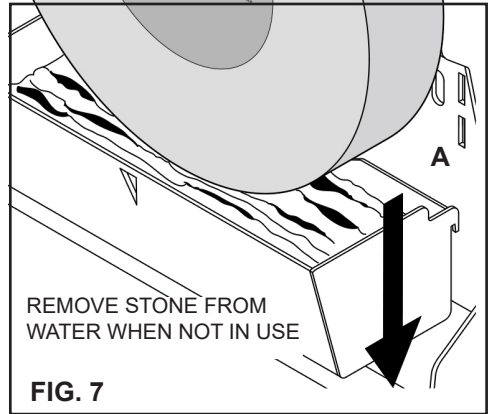

- Empty, rinse, and refill the reservoir regularly. This prevents metal and stone debris from accumulating in the reservoir.
- Place a magnet in the reservoir to catch and collect metal filings. This will help prevent excessive metal accumulation on the grinding wheel.

## CAUTION !

Always keep the switch "OFF" and unplug the machine when the sharpener is not in use. In the event of a power failure, blown fuse, or tripped circuit breaker, turn the switch "OFF" and unplug the machine to prevent accidental start-up when the power comes back on.

## ANGLE GUIDE

The sharpener comes with an angle guide to help identify and maintain the cutting angle on a variety of tools.

To use the angle guide:

- The wet sharpener must not be running for the following steps!
- Locate the eight measuring notches on the angle finder.
- Find the angle notch that best fits the tool you wish to grind by placing the sharpened edge of the workpiece into each notch.
- Adjust the positioning of the tool and the universal support height as necessary so that the sharpened edge of the tool is flat against both the

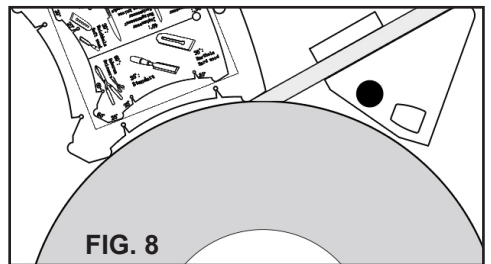

grinding wheel and the angle edge on the angle guide. Figure 8.

- Once the tool rest is properly positioned, and the angle guide is removed from the wheel & tool, the wet sharpener can be started so that the grinding can begin.

# OPERATION

## WHEEL DRESSING

Depending on the type of grinding you do, the grinding wet wheel may require periodic dressing. A variety of dressing tools are available separately (abrasive stones, diamond tipped dressers, etc.) and can be used to restore the abrasive quality of the wheel.

Dressing will remove buildup up of material on the grinding wheel, remove imperfections and make the corners of the grinding wheel square. Refer to the instructions that accompany your dressing accessory for complete details on how to properly dress a wheel.

Typical wheel dressing steps:

1. Adjust tool rest until it is in the flat, horizontal position and about 1/16" away from the grinding wheel.
2. Turn "ON" the machine and after the wheel has gotten to a steady speed, place the wheel dresser head flat on the tool rest.
3. Firmly hold onto the dresser so that it will not slip at any time during the dressing process.

4. Move the wheel dresser forward until it makes light contact with the wet wheel. After contact has been made, slide the wheel dresser side to side across the tool rest to dress the grinding wheel until the edges of the grinding wheel are square and the surface is clean.

5. After the dressing the grinding wheel, turn "OFF" the machine and let the grinding wheel come to a complete stop. Inspect the grinding wheel for any irregularities that still need to be dressed, or for any damage. If there is damage to the wheel (cracks, major chips missing), replace the wheel immediately.

6. The grinding wheel may now be slightly smaller in diameter after dressing. Re-adjust the tool rest to maintain a 1/16" clearance to the grinding wheel, and re-dress the stone if necessary.

---

**NOTE:** When grinding, metal objects become heated quickly. It is important to keep moving the object back and forth across the face of the grinding wheel and to cool the object frequently using the coolant tray.

---

## SHARPENING

The leather stropping wheel on the sharpener and the included abrasive stropping paste can be used to obtain a razor sharp edge on many tools. Before use, the stropping wheel must be properly prepared. Figure 9.

To prepare the stropping wheel:

- DISCONNECT SHARPENER FROM POWER!
- Evenly apply a light machine oil to the leather wheel. Use enough oil to provide a thorough coating, but not so much as to saturate the leather and result in dripping.
- Apply a thin coat of abrasive honing paste to the leather wheel using a wooden spreader or similar device. Distribute the paste evenly over the whole surface of the wheel.
- Connect the machine to power, then turn the machine on and continue to distribute the paste, still using the wooden spreader. Move the spreader lightly in a circular motion across the wheel.
- Once the paste is evenly distributed, begin sharpening.

FIG. 9

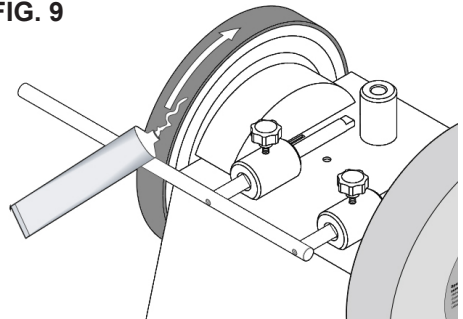

- These preparations will be sufficient for sharpening five to ten tools. If you notice a drop in sharpening performance or have sharpened more than ten tools, repeat the above steps.

**NOTE:** A slight wobble of the stropping wheel when it is rotating is normal and does not affect the performance.

# OPERATION

## PERMANENT MOUNTING

To avoid serious injury, use the mounting holes in the base of the wet sharpener to firmly attach it to a solid work surface or stand (mounting hardware and stand not included). Figure 10.

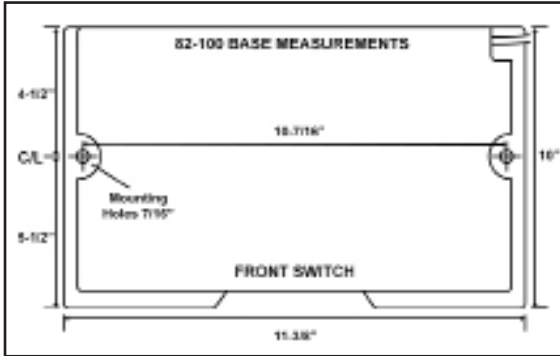

If the sharpener is not permanently mounted to a work surface, and remains portable, the machine's base should be temporarily clamped to a table or board/plywood. Make sure that the clamps do not interfere with machine parts or hinders the movement of the user and the material being ground during use.

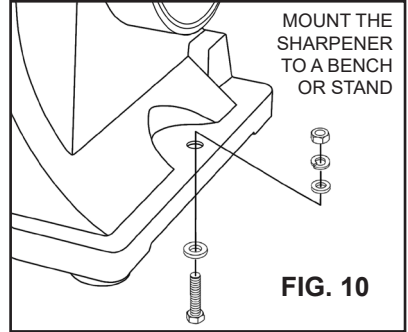

# MAINTENANCE

## **WARNING:**

Turn the power switch "OFF" and unplug the power cord from its power source prior to any maintenance.

## LUBRICATION

The Wet Sharpener has sealed lubricated bearings in the motor housing that do not require any additional lubrication from the operator.

## CLEANING

With the Wet Sharpener unplugged, rotate the abrasive wheel slowly and inspect for any damage or trapped debris. Periodically clean the areas in and around the grinder to keep the machine, water reservoir and work area clean.

## WATER RESERVOIR

Be sure to periodically empty, rinse and refill the water reservoir with clean water depending on frequency of use. Failing to do so can lead to a build-up of sediment on the wheel itself, reducing grinding performance.

## CAUTION: DO NOT USE FLAMMABLE

**MATERIALS** to clean the machine. A clean dry rag or brush is all that is needed to remove dust and debris buildup.

## GRINDING WHEEL

The grinding wheel should be inspected before every use. Take care in storing grinding wheels to keep them free from potential damage from moisture, freezing, from being dropped, or from having other items drop on them.

REPLACE the abrasive wheel if there is any damage at all. **FAILURE** to replace a damaged wheel can cause serious injury to the operator. Periodically check all nuts and fasteners to make sure that they are secure.

## Wheel Replacement

To replace the grinding or stropping wheel:

- Disconnect the machine from power!
- Hold the wheel to stop it from turning, and remove the arbor nut or knob which holds the wheel on.
- Remove the outer washer and wheel.
- Install the new wheel, then replace the washer and nut or knob.

## **WARNING:**

Repairs to the Wet Sharpener should be performed by trained personnel only. Unauthorized repairs or replacement with non-factory parts could cause serious injury to the operator and damage to the machine.

# WIRING DIAGRAM

**⚠ WARNING:**

This machine must be grounded. Replacement of the power supply cable should only be done by a qualified electrician. See pages 6 and 7 for additional electrical information.

This tool is intended for use on a circuit that has a 120 volt electrical receptacle. The illustration on page 7 shows the type of the 120v, 3-wire electrical plug and electrical receptacle that has a grounding conductor that is required.

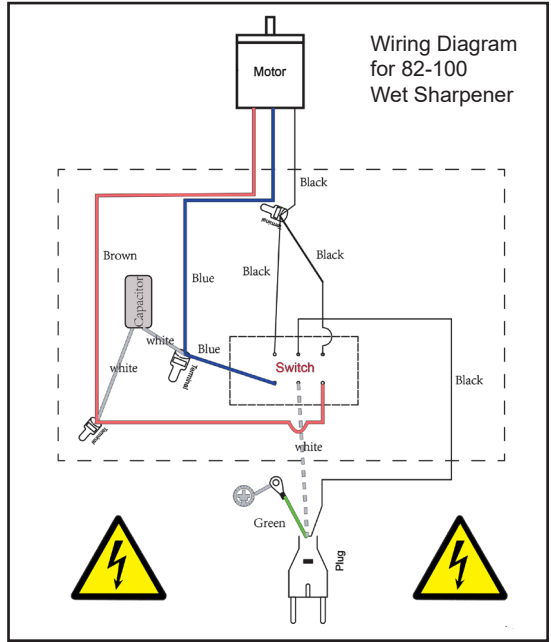

## NOTES

# PARTS DIAGRAM

## 82-100 8" WET GRINDER

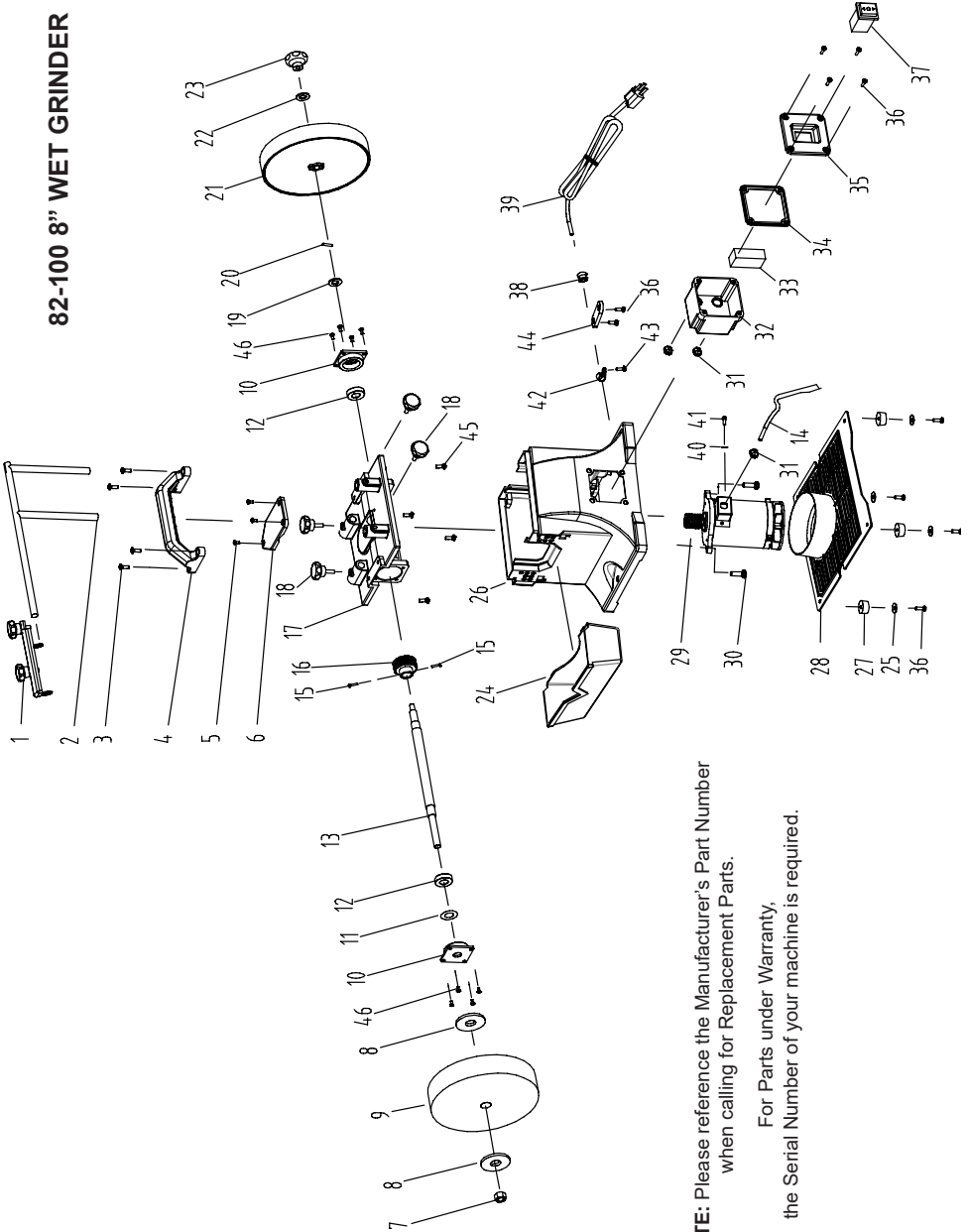

**NOTE:** Please reference the Manufacturer's Part Number when calling for Replacement Parts.

For Parts under Warranty, the Serial Number of your machine is required.



# PARTS LIST

KEY NO.	DESCRIPTION	QTY	MFG. PART NO.	KEY NO.	DESCRIPTION	QTY	MFG. PART NO.
1	Blade holder assembly	1	P82-100-1	24	Water tank	1	P82-100-24
2	Tool rest 'F' support $\phi$ 12mm	1	P82-100-2	25	Hex flange facing nut	4	P82-100-25
3	Phillips screw, flat+sprng washers M6x16	4	P82-100-3	26	Base assembly	1	P82-100-26
4	Handle	1	P82-100-4	27	Rubber foot	4	P82-100-27
5	Phillips screw M4x8	3	P82-100-5	28	Base plate	1	P82-100-28
6	Worm gear case cover	1	P82-100-6	29	Motor assembly	1	P82-100-29
7	Nut M12	1	P82-100-7	30	Phillips screw, flat+sprng washers M8x35	2	P82-100-30
8	Flange	2	P82-100-8	31	Strain relief 6P4	3	P82-100-31
9	Grinding wheel $\phi$ 200x40x $\phi$ 12mm	1	P82-100-9	32	Wire connection box	1	P82-100-32
10	Bearing block	2	P82-100-10	33	Capacitor	1	P82-100-33
11	Wave washer D32	1	P82-100-11	34	Rubber mat	1	P82-100-34
12	Bearing 6002RZ	2	P82-100-12	35	Switch plate	1	P82-100-35
13	Main shaft	1	P82-100-13	36	Tapping Screw ST4.2x16	10	P82-100-36
14A	Power cable	1	P82-100-14A	37	Bilateral on/off switch	1	P82-100-37
15A	Phillips screw + spring washer M5x12	2	P82-100-15A	38	Wire bushing	1	P82-100-38
16	Worm gear	1	P82-100-16	39	Cord & plug	1	P82-100-39
17	Worm gear case	1	P82-100-17	40	Tooth locking washer	1	P82-100-40
18	Knob M6x10	4	P82-100-18	41	Phillips screw, flat+sprng washers M4x8	1	P82-100-41
19	Washer D12	1	P82-100-19	42	Power cord clip	1	P82-100-42
20	Round pin $\phi$ 5x22	1	P82-100-20	43	Phillips tapping screw ST4.2x8	1	P82-100-43
21	Polishing wheel $\phi$ 200x30x $\phi$ 12.5mm	1	P82-100-21	44	Strain relief fix plate	1	P82-100-44
22	Big flat washer $\phi$ 8	1	P82-100-22	45	Phillips screw, flat+sprng washers M6x20	4	P82-100-45
23	Lock knob M8	1	P82-100-23	46A	Phillips screw M4x10	8	P82-100-46A

**NOTE:** Please reference the Manufacturer's Part Number when calling for Replacement Parts.

For Parts under Warranty, the Serial Number of your machine is required.

# TROUBLESHOOTING

TO PREVENT INJURY TO YOURSELF or damage to the Wet Grinder, turn the switch to the “OFF” position and unplug the power cord from the electrical receptacle before making any adjustments.

Symptom	Probable Cause	Corrective Action
Motor will not start	Low voltage	Check power source for proper voltage
	Open circuit in motor or loose connections	Inspect motor for loose or open connections. Send motor for servicing if necessary
	Blown fuse or breaker	Replace fuse or reset breaker
Motor overheats	Motor overloaded	Reduce load on motor
	Extension cord too long and/or of insufficient gauge (weight)	Use an extension cord of appropriate gauge and length or plug the sharpener directly into a correct wall outlet
Motor stalls (resulting in blown fuses or tripped breakers)	Shot circuit in motor or loose connections	Inspect motor for loose or shorted terminals or worn insulation. Send motor for servicing if necessary
	Low voltage	Correct low voltage condition (for example: improper extension cord length or gauge)
	Incorrect fuses or circuit breakers in power line	Install correct fuses or circuit breakers or plug sharpener into a circuit with correct fuses or breakers
	Motor overload	Reduce load on motor
Polishing wheel loses performance	Insufficient wheel preparations	Properly prepare wheel
	Wheel is damaged	Replace wheel
Wavy surface of work piece	Sharpener vibrating	Make sure the sharpener is securely positioned on a level surface
	Work piece is not held firmly	Check the knobs of the tool holder and tool support bar and tighten is necessary. If a knob is stripped, replace it.
	Wheel face is uneven	Dress the grinding wheel
Machine runs w/ noises	Short of lubricating	Added lubricating grease on the gear

# WARRANTY

## **RIKON** **POWER TOOLS**

### **2-Year Limited Warranty**

RIKON Power Tools Inc. ("Seller") warrants to only the original retail consumer/purchaser of our products that each product be free from defects in materials and workmanship for a period of two (2) years from the date the product was purchased at retail. This warranty may not be transferred.

This warranty does not apply to defects due directly or indirectly to misuse, abuse, negligence, accidents, repairs, alterations, lack of maintenance or normal wear and tear. Under no circumstances will Seller be liable for incidental or consequential damages resulting from defective products. All other warranties, expressed or implied, whether of merchantability, fitness for purpose, or otherwise are expressly disclaimed by Seller. This warranty does not cover products used for commercial, industrial or educational purposes.

This limited warranty does not apply to accessory items such as blades, drill bits, sanding discs, grinding wheels or belts and other related items.

Seller shall in no event be liable for death, injuries to persons or property, or for incidental, contingent, special, or consequential damages arising from the use of our products.

To take advantage of this warranty proof of purchase documentation, which includes date of purchase and an explanation of the complaint, must be provided.

The Seller reserves the right to effect at any time, without prior notice, those alterations to parts, fittings, and accessory equipment which they may deem necessary for any reason whatsoever.

To register your machine online, visit RIKON at [www.rikontools.com/warranty](http://www.rikontools.com/warranty)

To take advantage of this warranty, or if you have any questions, please contact us at 877-884-5167 or email [warranty@rikontools.com](mailto:warranty@rikontools.com)



For more information:  
16 Progress Road  
Billerica, MA 01821

877-884-5167 / 978-528-5380  
techsupport@rikontools.com

