

Air Filtration System 1100 CFM



Operator's Manual

Record the serial number and date of purchase in your manual for future reference.
The serial number can be found on the specification label on the rear of your machine.

Serial Number: _____ Date of purchase: _____

For technical support or parts questions, email techsupport@rikontools.com or call toll free at (877)884-5167

TABLE OF CONTENTS

Specifications.....	2
Safety Warnings.....	2-6
Air Filtration Safety Rules.....	7
Unpacking and Contents.....	7
Getting to Know Your Air Filtration System.....	8
Assembly.....	8-10
Operation.....	10-11
Maintenance.....	12-13
Troubleshooting.....	14
Wiring Diagram.....	15
Notes.....	15
Parts Diagrams.....	16-17
Parts List.....	18
Accessories.....	19
Warranty.....	19

SPECIFICATIONS

Model Number.....	62-1100
Cubic Feet Per Minute (max).....	1100 CFM
Motor	1/2HP, 120V, 4.2 A, 60 Hz, 1Ph
Speeds (3)	560, 750, 1100 CFM
Timer (3)	1Hr, 2Hr, 4Hr
Cycles per Hour	20' x 20' x 8' Room 13 / 17 / 22 Times per Hr
Filter Ratings	Outer = 5 Microns / Inner = 1 Micron
Filter Size Outer	12" x 24" x 1" (304.80 x 609.60 x 25.40 mm)
Filter Size Inner	12" x 24" x 7" (304.80 x 609.60 x 117.80 mm)
Blower Wheel Material	Steel
Blower Wheel Type	Squirrel Cage
Sound Ratings (L/M/H @3Ft)	66 / 70 / 73dB
Cabinet Size (LxWxH)	27.75" x 24.5" x 12.5" (704.85 x 622.30 x 317.50 mm)
Net Weight	61 lbs (27.5 kg)

California Proposition 65 Warning

 **WARNING:** Some dust created by power sanding, sawing, grinding, drilling, and other construction activities contains chemicals known to the State of California to cause cancer and birth defects or other reproductive harm.

Your risk from exposure to these chemicals varies, depending on how often you do this type of work.



To reduce your exposure, work in a well-ventilated area and with approved safety equipment, such as dust masks that are specially designed to filter out microscopic particles.

For more information go to www.P65Warnings.ca.gov/wood.

NOTE: The specifications, photographs, drawings and information in this manual represent the current model when the manual was prepared. Changes and improvements may be made at any time, with no obligation on the part of Rikon Power Tools, Inc. to modify previously delivered units. Reasonable care has been taken to ensure that the information in this manual is correct, to provide you with the guidelines for the proper safety, assembly and operation of this machine.

SAFETY SYMBOLS

The purpose of safety symbols is to attract your attention to possible dangers. The safety symbols and the explanations with them deserve your careful attention and understanding. The symbol warnings do not, by themselves, eliminate the danger. The instructions and warnings they give are no substitutes for proper accident prevention measures.

Symbol	Name	Designation / Explanation
V	Volts	Voltage
A	Amperes	Current
Hz	Hertz	Frequency (cycles per second)
W	Watts	Power
~	Alternating current	Type of current
—	Direct current	Type of characteristic of current
n _o	No-load speed	Rotational speed at no load
	Class II construction	Double insulated construction
.../min	Per minute	Revolutions, strokes, surface speed orbits, etc., per minute
	Wear safety goggles	⚠ WARNING: The operation of any power tool can result in foreign objects being thrown into your eyes, which can result in severe eye damage. Before beginning power tool operation, always wear safety goggles or safety glasses with side shields and a full-face shield when needed. We recommend a Wide Vision Safety Mask for use over eye-glasses or standard safety glasses with side shields. Always use eye protection which is marked to comply with ANSI Z87.1.

⚠ WARNING: To ensure safety and reliability, all repairs should be performed by a qualified service technician.

⚠ WARNING: Be sure to read and understand all safety instructions in this manual, including all safety alert symbols such as “DANGER,” “WARNING,” and “CAUTION” before using this tool. Failure to following all instructions listed below may result in electric shock, fire, and/or serious personal injury.

SYMBOL MEANING

⚠ SAFETY ALERT SYMBOL: Indicates DANGER, WARNING, OR CAUTION. May be used in conjunction with other symbols or pictographs.

⚠ DANGER: Indicates an imminently hazardous situation, which, if not avoided, will result in death or serious injury.

⚠ WARNING: Indicates a potentially hazardous situation, which, if not avoided, could result in death or serious injury.

⚠ CAUTION: Indicates a potentially hazardous situation, which, if not avoided, could result in minor or moderate injury.

NOTICE: (Without Safety Alert Symbol) Indicates a situation that may result in property damage.



THIS SYMBOL DESIGNATES THAT THIS TOOL IS LISTED BY THE INTERTEK TESTING SERVICES, TO UNITED STATES AND CANADIAN STANDARDS

SAFETY INSTRUCTIONS

IMPORTANT! Safety is the single most important consideration in the operation of this equipment. **The following instructions must be followed at all times.**

There are certain applications for which this tool was designed. We strongly recommend that this tool not be modified and/or used for any other application other than that for which it was designed. If you have any questions about its application, do not use the tool until you have contacted us and we have advised you.

GENERAL SAFETY

KNOW YOUR POWER TOOL. Read the owner's manual carefully. Learn the tool's applications, work capabilities, and its specific potential hazards.

BEFORE USING THE AIR FILTRATION SYSTEM

To avoid serious injury and damage to the tool, read and follow all of the Safety and Operating Instructions before operating the machine.

1. Some dust created by using power tools contains chemicals known to the State of California to cause cancer, birth defects, or other reproductive harm.

Some examples of these chemicals are:

- Lead from lead-based paints.
- Crystalline silica from bricks, cement, and other masonry products.
- Arsenic and chromium from chemically treated lumber.

Your risk from these exposures varies, depending on how often you do this type of work. To reduce your exposure to these chemicals: work in a well ventilated area and work with approved safety equipment, such as those dust masks that are specially designed to filter out microscopic particles.

2. **READ** the entire Owner's Manual. **LEARN** how to use the tool for its intended applications.

3. **GROUND ALL TOOLS.** If the tool is supplied with a 3-prong plug, it must be plugged into a 3-contact electrical receptacle. The 3rd prong is used to ground the tool and provide protection against accidental electric shock. **DO NOT** remove the 3rd prong. See Grounding Instructions on page 6.

4. **AVOID A DANGEROUS WORKING ENVIRONMENT.** **DO NOT** use electrical tools in a damp environment or expose them to rain.

5. **DO NOT** use electrical tools in the presence of flammable liquids or gasses.

6. **ALWAYS** keep the work area clean, well lit, and organized. **DO NOT** work in an environment with floor surfaces that are slippery from debris, grease, and wax.

7. **KEEP VISITORS AND CHILDREN AWAY. DO NOT** permit people to be in the immediate work area, especially when the electrical tool is operating.

8. **DO NOT FORCE THE TOOL** to perform an operation for which it was not designed. It will do a safer and higher quality job by only performing operations for which the tool was intended.

9. **WEAR PROPER CLOTHING. DO NOT** wear loose clothing, gloves, neckties, or jewelry. These items can get caught in the machine during operations and pull the operator into the moving parts. The user must wear a protective cover on their hair, if the hair is long, to prevent it from contacting any moving parts.

10. **CHILDPROOF THE WORKSHOP AREA** by removing switch keys, unplugging tools from the electrical receptacles, and using padlocks.

11. **ALWAYS UNPLUG THE TOOL FROM THE ELECTRICAL RECEPTACLE** when making adjustments, changing parts or performing any maintenance.

12. **KEEP PROTECTIVE GUARDS IN PLACE AND IN WORKING ORDER.**

13. **AVOID ACCIDENTAL STARTING.** Make sure that the power switch is in the "OFF" position before plugging in the power cord to the electrical receptacle.

14. **REMOVE ALL MAINTENANCE TOOLS** from the immediate area prior to turning "ON" the machine.

15. **USE ONLY RECOMMENDED ACCESSORIES.** Use of incorrect or improper accessories could cause serious injury to the operator and cause damage to the tool. If in doubt, check the instruction manual that comes with that particular accessory.

SAFETY INSTRUCTIONS

16. NEVER LEAVE A RUNNING TOOL UNATTENDED.

Turn the power switch to the "OFF" position. **DO NOT** leave the tool until it has come to a complete stop.

17. **DO NOT STAND ON A TOOL.** Serious injury could result if the tool tips over, or you accidentally contact the tool.

18. **DO NOT** store anything above or near the tool where anyone might try to stand on the tool to reach it.

19. **MAINTAIN YOUR BALANCE. DO NOT** extend yourself over the tool. Wear oil resistant rubber soled shoes. Keep floor clear of debris, grease, and wax.

20. **MAINTAIN TOOLS WITH CARE.** Always keep tools clean and in good working order. Keep all blades and tool bits sharp, dress grinding wheels and change other abrasive accessories when worn.

21. **EACH AND EVERY TIME, CHECK FOR DAMAGED PARTS PRIOR TO USING THE TOOL.** Carefully check all guards to see that they operate properly, are not damaged, and perform their intended functions. Check for alignment, binding or breaking of moving parts. A guard or other part that is damaged should be immediately repaired or replaced.

22. **DO NOT OPERATE TOOL WHILE TIRED, OR UNDER THE INFLUENCE OF DRUGS, MEDICATION OR ALCOHOL.**

23. **SECURE ALL WORK.** Use clamps or jigs to secure the workpiece. This is safer than attempting to hold the workpiece with your hands.

24. **STAY ALERT, WATCH WHAT YOU ARE DOING, AND USE COMMON SENSE WHEN OPERATING A POWER TOOL.** A moment of inattention while operating power tools may result in serious personal injury.

25. **ALWAYS WEAR A DUST MASK TO PREVENT INHALING DANGEROUS DUST OR AIRBORNE PARTICLES,** including wood dust, crystalline silica dust and asbestos dust. Direct particles away from face and body. Always operate tool in well ventilated area and provide for proper dust removal. Use dust collection system wherever possible. Exposure to the dust may cause serious and permanent respiratory or other injury, including silicosis (a serious lung disease), cancer, and death. Avoid breathing the dust, and avoid prolonged contact with dust. Allowing dust to get into your mouth or eyes, or lay on your skin may promote absorption of harmful material. Always use properly fitting NIOSH/OSHA approved respiratory protection appropriate for the dust exposure, and wash exposed areas with soap and water.

26. **USE A PROPER EXTENSION CORD IN GOOD CONDITION.** When using an extension cord, be sure to use one heavy enough to carry the current your product will draw. The table on page 6 shows the correct size to use depending on cord length and nameplate amperage rating. If in doubt, use the next heavier gauge. The smaller the gauge number, the larger diameter of the extension cord. If in doubt of the proper size of an extension cord, use a shorter and thicker cord. An undersized cord will cause a drop in line voltage resulting in a loss of power and overheating. **USE ONLY A 3-WIRE EXTENSION CORD THAT HAS A 3-PRONG GROUNDING PLUG AND A 3-POLE RECEPTACLE THAT ACCEPTS THE TOOL'S PLUG.**

27. **ADDITIONAL INFORMATION** regarding the safe and proper operation of this product is available from:

- Power Tool Institute
1300 Summer Avenue
Cleveland, OH 44115-2851
www.powertoolinstitute.org
- National Safety Council
1121 Spring Lake Drive
Itasca, IL 60143-3201
www.nsc.org
- American National Standards Institute
25 West 43rd Street, 4th Floor
New York, NY 10036
www.ansi.org
- ANSI 01.1 Safety Requirements for
Woodworking Machines and the
U.S. Department of Labor regulations
www.osha.gov

28. **SAVE THESE INSTRUCTIONS.** Refer to them frequently and use them to instruct others.

ELECTRICAL SAFETY

 **WARNING:** THIS TOOL MUST BE GROUNDED WHILE IN USE TO PROTECT THE OPERATOR FROM ELECTRIC SHOCK.

IN THE EVENT OF A MALFUNCTION OR BREAKDOWN, grounding provides the path of least resistance for electric current and reduces the risk of electric shock. This tool is equipped with an electric cord that has an equipment grounding conductor and a grounding plug. The plug **MUST** be plugged into a matching electrical receptacle that is properly installed and grounded in accordance with **ALL** local codes and ordinances.

ELECTRICAL SAFETY (Continued on Pg.6)

SAFETY INSTRUCTIONS

ELECTRICAL SAFETY (Continued from Pg.5)

DO NOT MODIFY THE PLUG PROVIDED.

If it will not fit the electrical receptacle, have the proper electrical receptacle installed by a qualified electrician.

IMPROPER ELECTRICAL CONNECTION of the equipment grounding conductor can result in risk of electric shock. The conductor with the green insulation (with or without yellow stripes) is the equipment grounding conductor. **DO NOT** connect the equipment grounding conductor to a live terminal if repair or replacement of the electric cord or plug is necessary.

CHECK with a qualified electrician or service personnel if you do not completely understand the grounding instructions, or if you are not sure the tool is properly grounded.

USE ONLY A 3-WIRE EXTENSION CORD THAT HAS A 3-PRONG GROUNDING PLUG AND A 3-POLE RECEPTACLE THAT ACCEPTS THE TOOL'S PLUG. REPLACE A DAMAGED OR WORN CORD IMMEDIATELY.

This tool is intended for use on a circuit that has an electrical receptacle as shown in **FIGURE 1**. **FIGURE 1** shows a 3-wire electrical plug and electrical receptacle that has a grounding conductor. If a properly grounded electrical receptacle is not available, an adapter as shown in **FIGURE 2** can be used to temporarily connect this plug to a 2-contact ungrounded receptacle. The adapter has a rigid lug extending from it that **MUST** be connected to a permanent earth ground, such as a properly grounded receptacle box. **THIS ADAPTER IS PROHIBITED IN CANADA.**

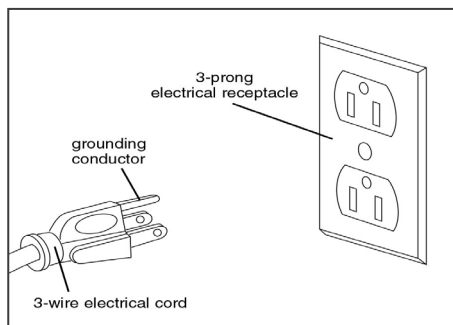

Figure 1

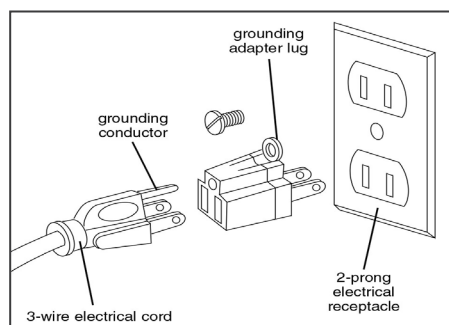

Figure 2

EXTENSION CORDS

WARNING: Keep the extension cord clear of the working area. Position the cord so that it will not get caught on lumber, tools or other obstructions while you are working with a power tool.

WARNING: Check extension cords before each use. If damaged replace immediately. Never use a tool with a damaged cord, since touching the damaged area could cause electrical shock, resulting in serious injury.

Use a proper extension cord. Only use cords listed by Underwriters Laboratories (UL). Other extension cords can cause a drop in line voltage, resulting in a loss of power and overheating of tool. When operating a power tool outdoors, use an outdoor extension cord marked "W-A" or "W". These cords are rated for outdoor use and reduce the risk of electric shock.

MINIMUM RECOMMENDED GAUGE FOR EXTENSION CORDS (AWG)				
120 VOLT OPERATION ONLY				
	25' LONG	50' LONG	100' LONG	150' LONG
0 to 6 Amps	18 AWG	16 AWG	16 AWG	14 AWG
6 to 10 Amps	18 AWG	16 AWG	14 AWG	12 AWG
10 to 12 Amps	16 AWG	16 AWG	14 AWG	12 AWG

To Reduce The Risk Of Fire Or Electric Shock, Do Not Use This Fan With Any Solid-State Speed Control Device.

Do not operate any fan with a damaged cord or plug. Discard fan or return to an authorized service facility for examination and/or repair.

Do not run cord under carpeting. Do not cover cord with throw rugs, runners, or similar coverings. Do not route cord under furniture or appliances. Arrange cord away from traffic area and where it will not be tripped over.

SAFETY INSTRUCTIONS

SPECIFIC SAFETY INSTRUCTIONS FOR AIR FILTRATION SYSTEMS

This machine is intended for the capture of airborn particles to keep the air clean in your woodworking shop. The permissible room dimensions must be observed (see Technical Specification). Any other use not as specified, including modification of the machine or use of parts not tested and approved by the equipment manufacturer can cause unforeseen damage and invalidate the warranty.

ATTENTION: Use of this air filtration system still presents risks that cannot be eliminated by the manufacturer. Therefore, the user must be aware that all machines are dangerous if not used with care, and all safety precautions are adhered to.

1. Do not operate this machine until you have read all of the following instructions.
2. Do not attempt to operate this machine until it is completely assembled.
3. Do not turn ON this machine if any pieces are missing.
4. If you are not familiar with the operation of the machine, obtain assistance from a qualified person.
5. Make sure that the System is secured in a horizontal position if hanging from the ceiling or positioned on a work surface.
6. Do not place System near an open ignition source - open flames, pilot lights, or grinding areas producing sparks.
7. Do not expose System to rain or dampness.
8. Use System for filtering wood dust only. Not for use filtering sheet rock dust, silica, lead paint dust, asbestos, biohazards, smoke, toxic fumes, spray paint or flammable liquids.
9. Do not use without filters in place.
10. Never duct a machine directly into the air filtration system.
11. Do not leave the System running unattended.
12. Always make sure the power switch is in the OFF position prior to plugging in the machine.
13. Always, disconnect (unplug) and make sure the power switch is in the OFF position when doing any assembly, setup, or when cleaning or changing filters.
14. Always wear a dust mask when cleaning or working near an air filtration system.
15. This machine must be properly grounded.
16. Always keep your face and hands clear of moving parts such as impellers and fans.

Contents of Package

Unpacking and Checking Contents

Carefully unpack your air filtration system from its carton and check to see that you have all of the following items. If any parts are missing or broken, please call RIKON Customer Service (877-884-5167) as soon as possible for replacements. Do not turn your machine ON if any of these items are missing. You may cause injury to yourself or damage to your machine.



A



B



C



D

- A . Air Filtration Unit
- B . Remote Control
- C . Hardware Bag
- D . Manual

GETTING TO KNOW YOUR AIR FILTRATION



Item Description

- A. Outlet
- B. Control Panel/Receiver
- C. Fuse
- D. Power Cord
- E. Outer Filter (1), Inner Filter (1)



Item Description

- F. Carrying Handle (x2)
- G. Remote Control
- H. Hanging Chains (4)
- I. Hangers and Locknuts (4)
- J. Wood Screw Hooks (4)



ASSEMBLY

The machine must not be plugged in and the power switch must be in the OFF position until assembly is complete.

Tools Required for Assembly



#2 Phillips Screwdriver



10mm Wrench

Unpacking and Clean-up

1. Carefully remove all contents from the shipping carton. Compare the contents with the list of contents to make sure that all of the items are accounted for, before discarding any packing material. Place parts on a protected surface for easy identification and assembly. If any parts are missing or broken, please call RIKON Customer Service (877- 884-5167) as soon as possible for replacements. **DO NOT** turn your machine ON if any of these items are missing. You may cause injury to yourself or damage to the machine.
2. Report any shipping damage to your local distributor. Take photographs for any possible insurance claims.
3. Clean all rust protected surfaces. **Do not use**; gasoline, paint thinner, mineral spirits, etc. These may damage painted surfaces.
4. Set packing material and shipping carton to the side. **Do not discard** until machine has been set up and is running properly.

ASSEMBLY

The air filter is designed to circulate air and filter wood and other non-metallic dust. The unit requires only minimal assembly. However, it is important to consider how and where to place the unit in your shop. When selecting a site, make sure there is a suitable power source.

Air Filtration System Placement:

The ideal location for an air filtration system is centered in the shop ceiling, mounted approximately 7-8 feet in the air away from corners, tall cabinets or heating/cooling vents that would restrict air flow. Another good location is above an area where a lot of sanding is done. Example; if you do lathe work and have a sanding center nearby, hang the air filtration unit between both areas. Depending on your shop size, you may need more than one air filtration system, or may have to choose a larger size. (Fig.03)

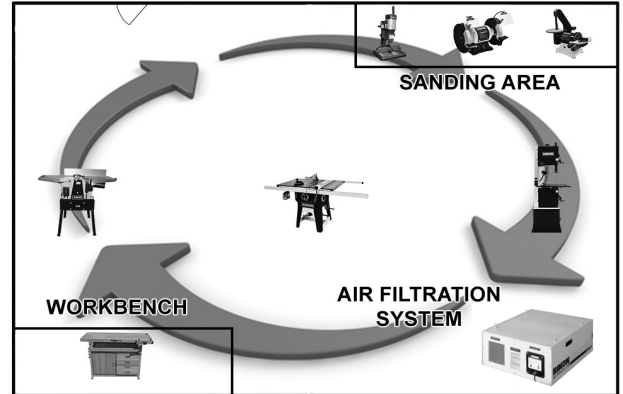

Fig.03

If hanging the unit is not an option, it can be mounted on a bench. Again, near an area that produces the most dust. The air filtration unit has 4 rubber feet installed for this purpose.

NOTE: Before installing the Air Filtration System in a ceiling location, test run the unit to make sure that it runs properly.

Hanger Installation (Fig.04 and Fig.05)

1. Thread the locknuts (A) almost all the way up the hangers (B).
2. Thread a hanger into each of the four mounting holes (C) on the top of the air filter cabinet.
3. Tighten each locknut against the cabinet top (A), securing the hanger in place. Hold the hanger so that it does not spin while tightening the locknut.

NOTICE: Make sure the unit will be situated at least 7' (2.1 m) above the floor and at least 3' (1 m) away from a corner and from any heating or air vents.

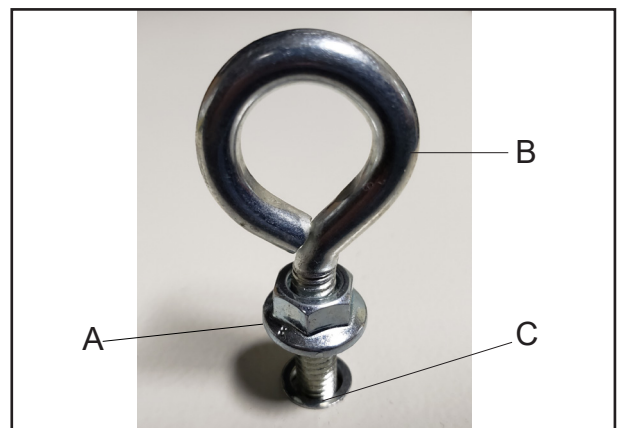

Fig.04



Fig.05

ASSEMBLY

Ceiling Placement (Fig.06)

4. Install the wood screw hooks (D) into the building's wooden ceiling joists (E). Do not mount the air filter to non-structural surfaces such as dry wall or false ceiling grids. The hooks are rated for this air filter system, and can support a maximum of 100 lbs (45 kg).

5. Place a chain (F) on each ceiling hook (D).

6. Attach the hangers (B) on each chain (F).

7. Make sure the unit is level horizontally, and is at least 7' (2.1 m) above the floor. If it is not, remove the air filter and adjust the length of the chain as needed. Then remount the unit.

8. Plug the air filter's power cord directly into a grounded power source.

NOTE: Do not place unit close to or directly under a light source. Doing so may result in poor operation or reduced range of the remote control.

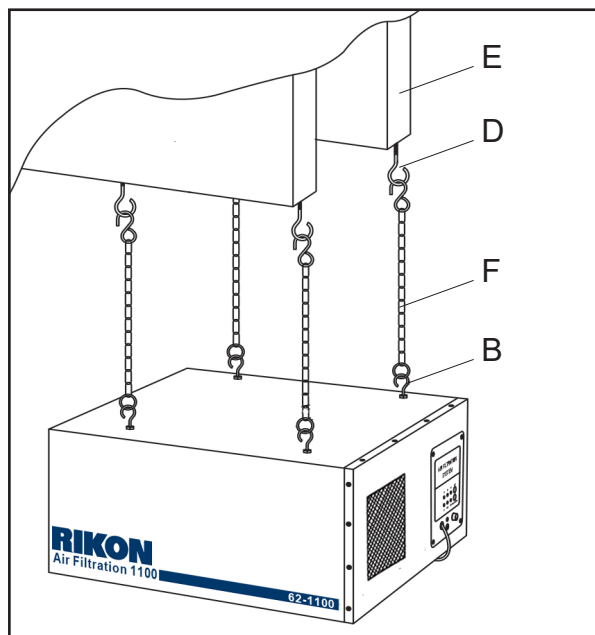
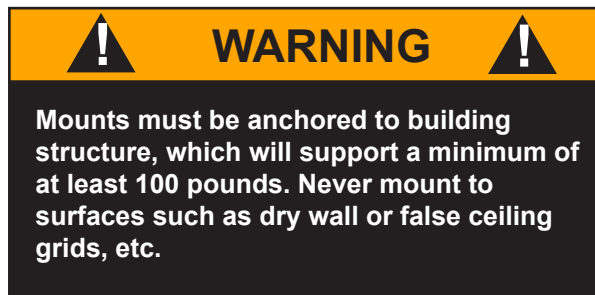

Fig.06

OPERATION

The air filter can be operated directly using the control panel or with the remote control. Note: The remote control and control panel must be in direct view of each other for the infrared signals to work.

Turn on the air filter and speed setting (Fig.07 and Fig.08)

1. Plug the power cord into an appropriate grounded power source.

2. Press the ON/SPEED button (A) on the control panel or the remote control to power on the air filter. The air filter will be running at low speed. The LOW LED will light, indicating that the unit has been worked at low speed.

(Continued on Pg.11)

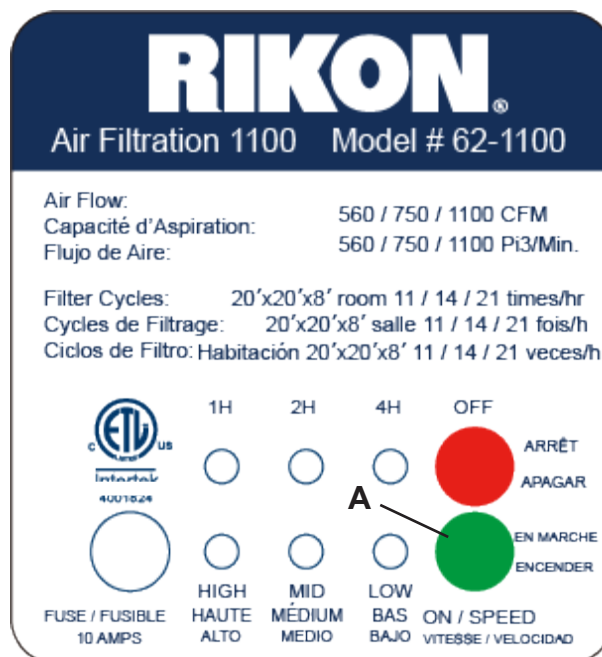

Fig.07

OPERATION

(Continued from Pg.10)

3. Press the ON/SPEED button (A) again to change the speed. The LEDs (B) next to the ON/SPEED button on the control panel will indicate the selected speed - Low, Medium, or High.

Set the timer (Fig.08 and Fig.09)

A timer allows you to set the length of time (1, 2, 4 hours and clear the timer) that the air filter will operate before shutting off automatically. The timer can be set ONLY with the remote control.

1. Press the TIME button (C) on the remote control (Fig.09) to start the timer.

2. Press the TIME button (C) on the remote control again to set the length of operation. The LEDs (D-Fig.08) on the control panel indicate the amount of time selected - 1 hour, 2 hours, 4 hours. Press a fourth time to clear the timer.

NOTE: The unit will shut off automatically after the selected time interval elapses. When you choose 'clear the timer', the air filter will keep running until you turn it off.

Turn off the Air Filter

To turn off the Air Filter, press the OFF button (E-Fig.08) on the control panel or (A-Fig.09) on the remote control.

Remote Control (Fig.09)

The air filtration system can also be operated with the supplied infrared remote control. The infrared receiver is located on the main control panel. The remote control has the same functions as the main control panel above in Fig.08. However; the timer can be set ONLY with the remote control. Fig.09, (C).

- ON / OFF button (A)
- SPEED button (B)
- TIMER button (C)

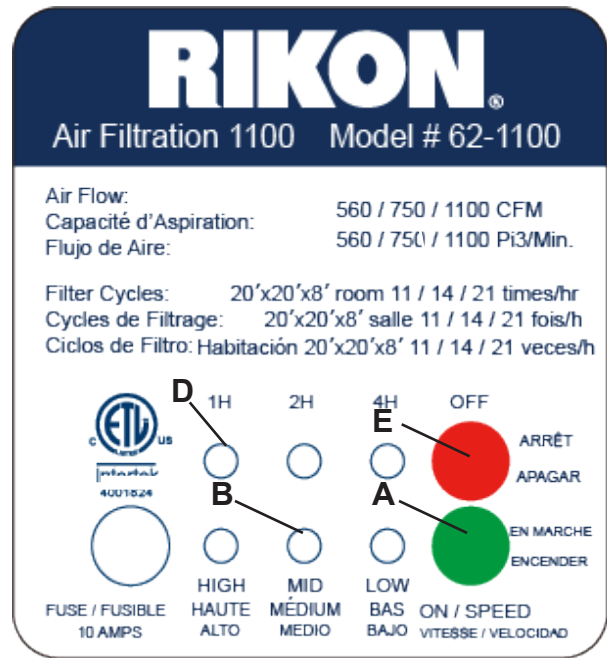

Fig.08

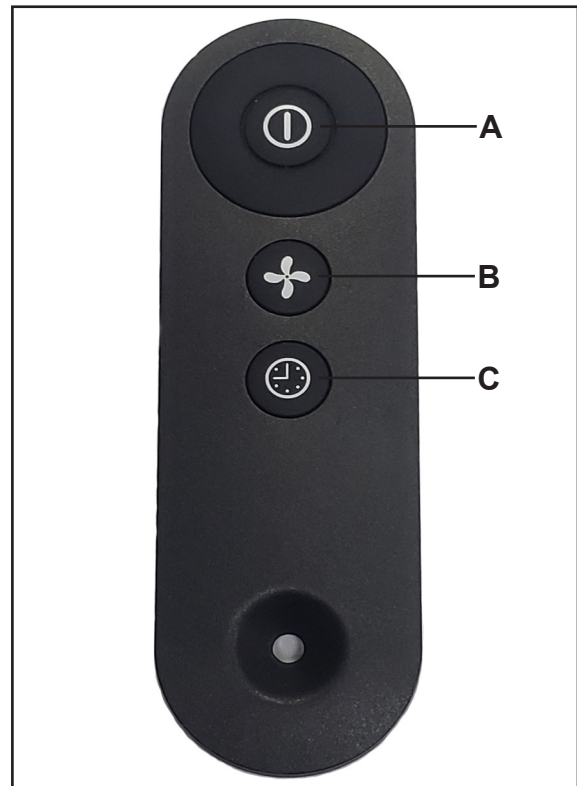

Fig.09

NOTE: Do not place unit close to or directly under a light source. Doing so may result in poor operation or reduced range of the remote control.

MAINTENANCE

Changing the Filters



WARNING



To reduce the risk of injury disconnect the air cleaner from the power source (unplug) before servicing or changing filters and fuses. Failure to comply may cause serious injury!

Change the filters (Fig.10 and 11)

NOTE: Care should be taken when handling soiled or contaminated filters. As certain fine dusts can be harmful. Always wear a suitable mask for additional protection.

Check the inner and outer filters periodically, depending on the amount of use, and change the filters when needed. Clogged filters will reduce the amount of air circulating through the filter.

1. Lift up the two clips Fig.10, (A) on the left and right of the cabinet and remove the outer filter Fig.11, (B) from the cabinet housing.

2. Pull the inner filter Fig.11, (C) out of the cabinet.

3. Install a new inner filter. Make sure the filter bags point inwards into the cabinet.

NOTE: The inner filter can be blown out with air, or washed out to extend its life. Make sure that a washed out filter is completely dry before re-installing it in the cabinet.

4. Install a new outer filter. The arrow on the outside of the filter indicates the proper direction to insert the filter into the cabinet. Fig.11, (D)

5. Lock the clips Fig.10, (A) on the left and right of the cabinet.

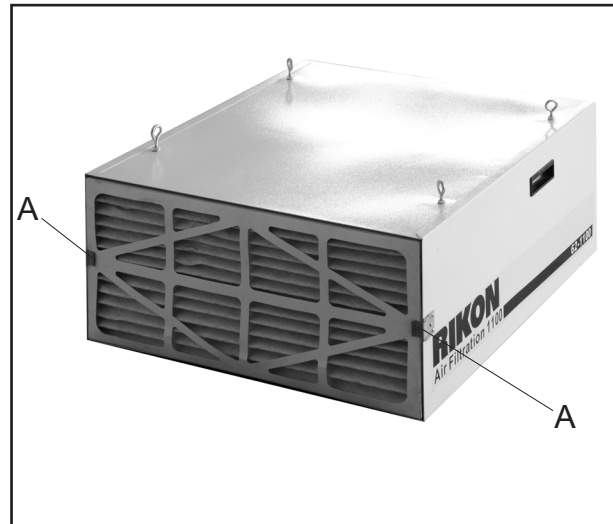

Fig.10

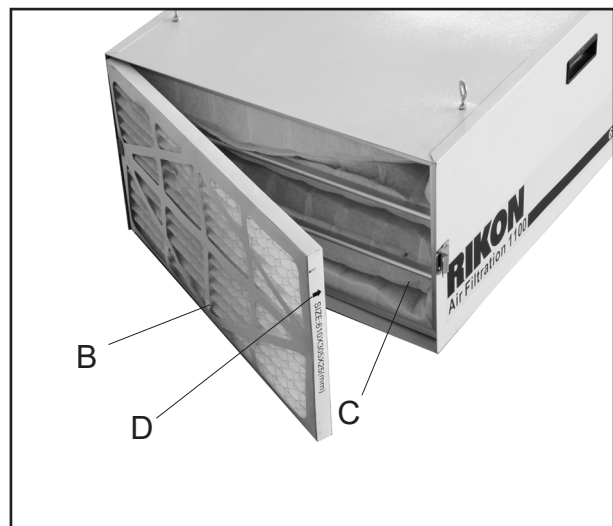

Fig.11

MAINTENANCE

Check and Replace the Fuse (Fig. 12)

1. Unplug unit from the receptacle or other outlet device.
2. Using a Phillips head screwdriver turn the fuse cover Fig.12, (A) counterclockwise to remove it. Carefully pull the fuse away from the control panel.
3. Insert a new fuse (5 Amps, 125V) in the fuse cover and reinstall into the control panel. Turn the fuse cover clockwise to re-install it in the panel.

⚠ WARNING: Risk of fire. Replace fuse only with 5 Amp, 125 Volt fuse.

Replacing the Remote Control Battery (Fig. 13)

1. Open the rear battery compartment panel on the remote control by turning the battery cover counterclockwise with a coin or flathead screwdriver.
2. Remove the old battery.
3. Install a new “CR2025” battery positive (+) side up according to the picture shown inside of the battery cover.
4. Close the battery compartment.

⚠ WARNING:

Chemical Burn Hazard. Keep batteries away from children.

This product contains a lithium button/coin cell battery. If a new or used lithium button/coin cell battery is swallowed or enters the body, it can cause severe internal burns and can lead to death in as little as 2 hours.

Always completely secure the battery compartment. If the battery compartment does not close securely, stop using the product, remove the batteries, and keep it away from children.

If you think batteries might have been swallowed or placed inside any part of the body, seek immediate medical attention.

The cells shall be disposed of properly, including keeping them away from children; and even used cells may cause injury.



Fig.12



Fig.13

TROUBLESHOOTING

TO PREVENT INJURY TO YOURSELF or damage to the Air Filtration System, turn the switch to the machine “OFF” and unplug the power cord from the electrical receptacle before making any adjustments.

PROBLEM	LIKELY CAUSE(S)	SOLUTION(S)
Motor does not run	<ol style="list-style-type: none"> 1. Machine not plugged in 2. Power switch in “OFF” position 3. Power switch or cord is faulty 4. Fuse or circuit breaker are open 5. Remote control is not working 6. Remote control batteries are dead 7. Infrared receiver is not working 8. Control panel ON/OFF button is not working 9. Control panel fuse is blown 10. Motor does not work 	<ol style="list-style-type: none"> 1. Plug power cord into electrical receptacle 2. Lift switch to “ON” position 3. Replace switch or power cord 4. Overloaded electrical circuit 5. Point remote control directly at control panel <ul style="list-style-type: none"> -Make sure infrared sensor on the control panel is not blocked -Move remote control closer to the control panel for better direct infrared signal 6. Replace batteries. See page 13 for instruction 7. Inspect or replace control panel circuit board 8. Inspect or replace control panel circuit board 9. Replace blown fuse, see page 13 for instruction 10. Replace motor
Motor stalls or does not have full power	<ol style="list-style-type: none"> 1. Incorrect line voltage 2. Motor capacitor has failed 3. Control panel circuit board has failed 	<ol style="list-style-type: none"> 1. Have a qualified electrician check circuit for proper voltage 2. Replace motor capacitor 3. Inspect or replace control panel circuit board
System has vibration or is noisy	<ol style="list-style-type: none"> 1. Motor or cabinet part is loose 2. Motor fan is rubbing cover 3. Motor bearings are loud 4. Air filters rattle 5. Impeller fan is loose, unbalanced or damaged 6. Motor base is loose in the cabinet 	<ol style="list-style-type: none"> 1. Inspect all hardware and retighten or replace 2. Check position of fan and cover <ul style="list-style-type: none"> Adjust or replace loose/damaged part 3. Rotate motor shaft to isolate the issue <ul style="list-style-type: none"> Replace worn bearings 4. Inspect and reposition filters 5. Turn machine off and unplug from power. <ul style="list-style-type: none"> -Inspect impeller for bent or damaged areas. -Secure impeller on motor shaft and replace if any damage is found 6. Tighten any loose fasteners
Poor air flow and dust collection	<ol style="list-style-type: none"> 1. Filters are dirty 2. Poor system location in shop 	<ol style="list-style-type: none"> 1. Clean or replace both air filters frequently. See page 12 2. Reposition system in the shop for best air circulation. Refer page 9 for proper air filtration system placement

WIRING DIAGRAM

WARNING: This machine must be grounded. Replacement of the power supply cable should only be done by a qualified electrician.

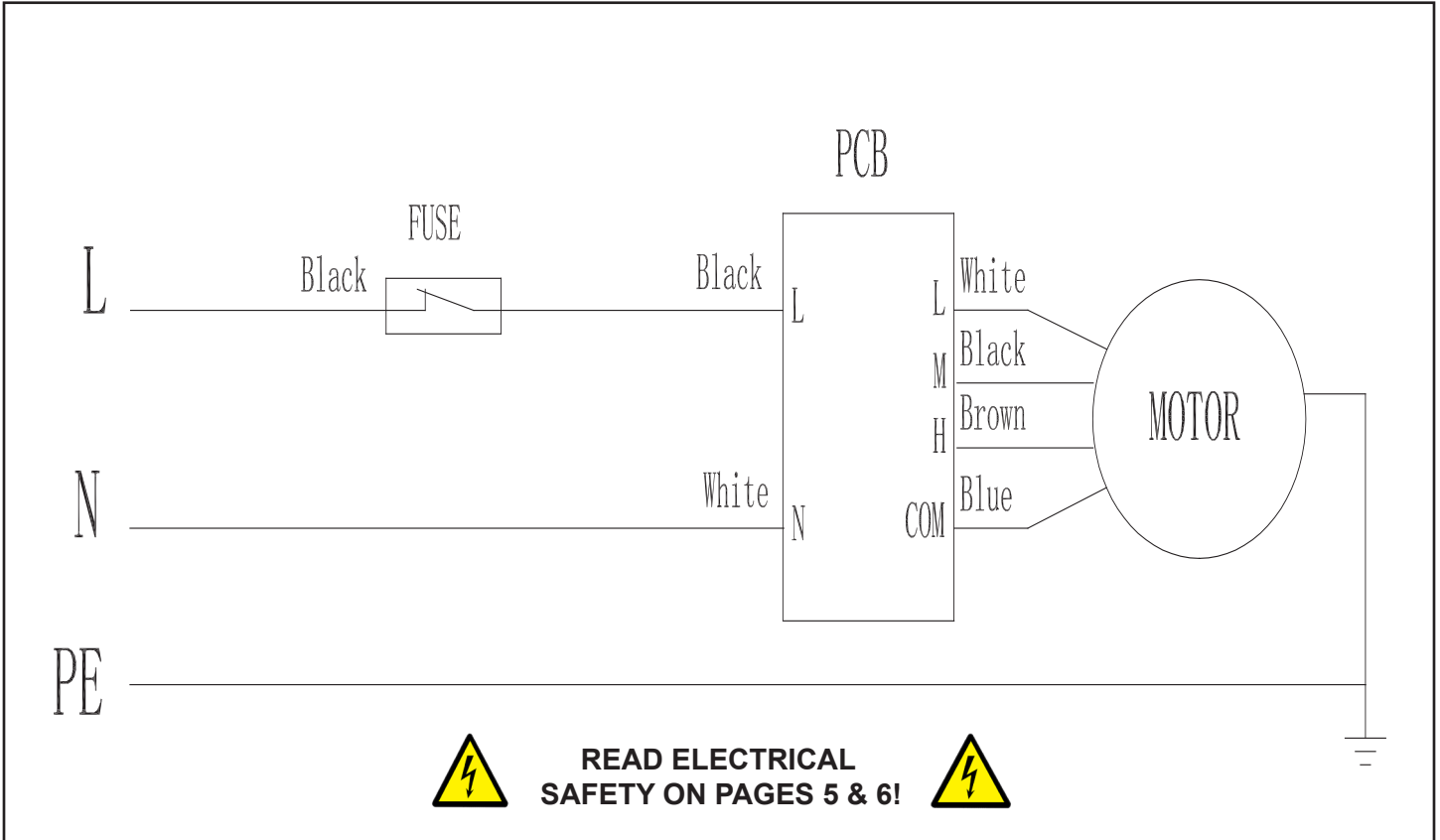

NOTES

Use this section to record maintenance, service and any calls to Technical Support.

PARTS EXPLOSION

CABINET ASSEMBLY

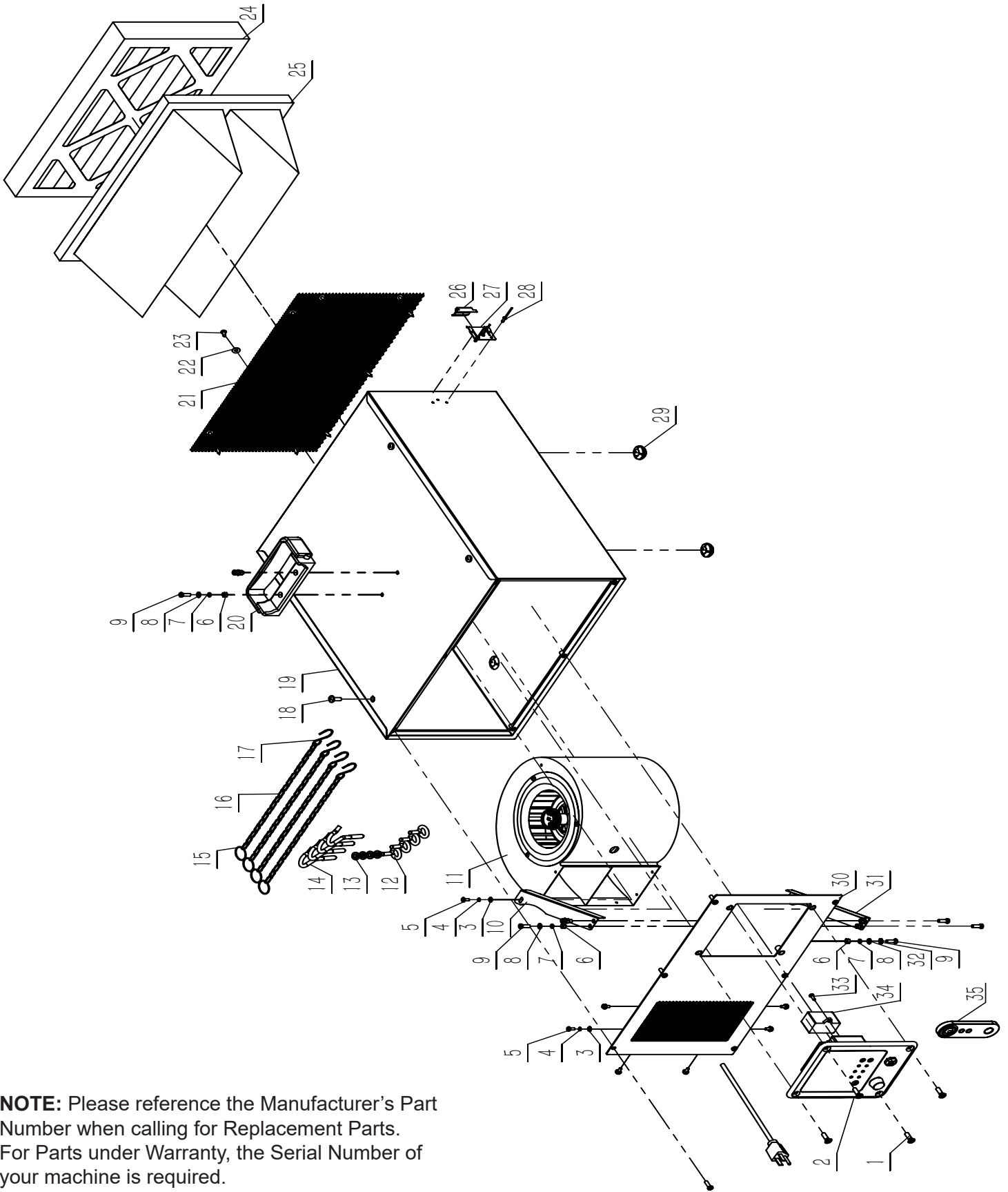

NOTE: Please reference the Manufacturer's Part Number when calling for Replacement Parts. For Parts under Warranty, the Serial Number of your machine is required.

PARTS EXPLOSION

MOTOR & BLOWER ASSEMBLY

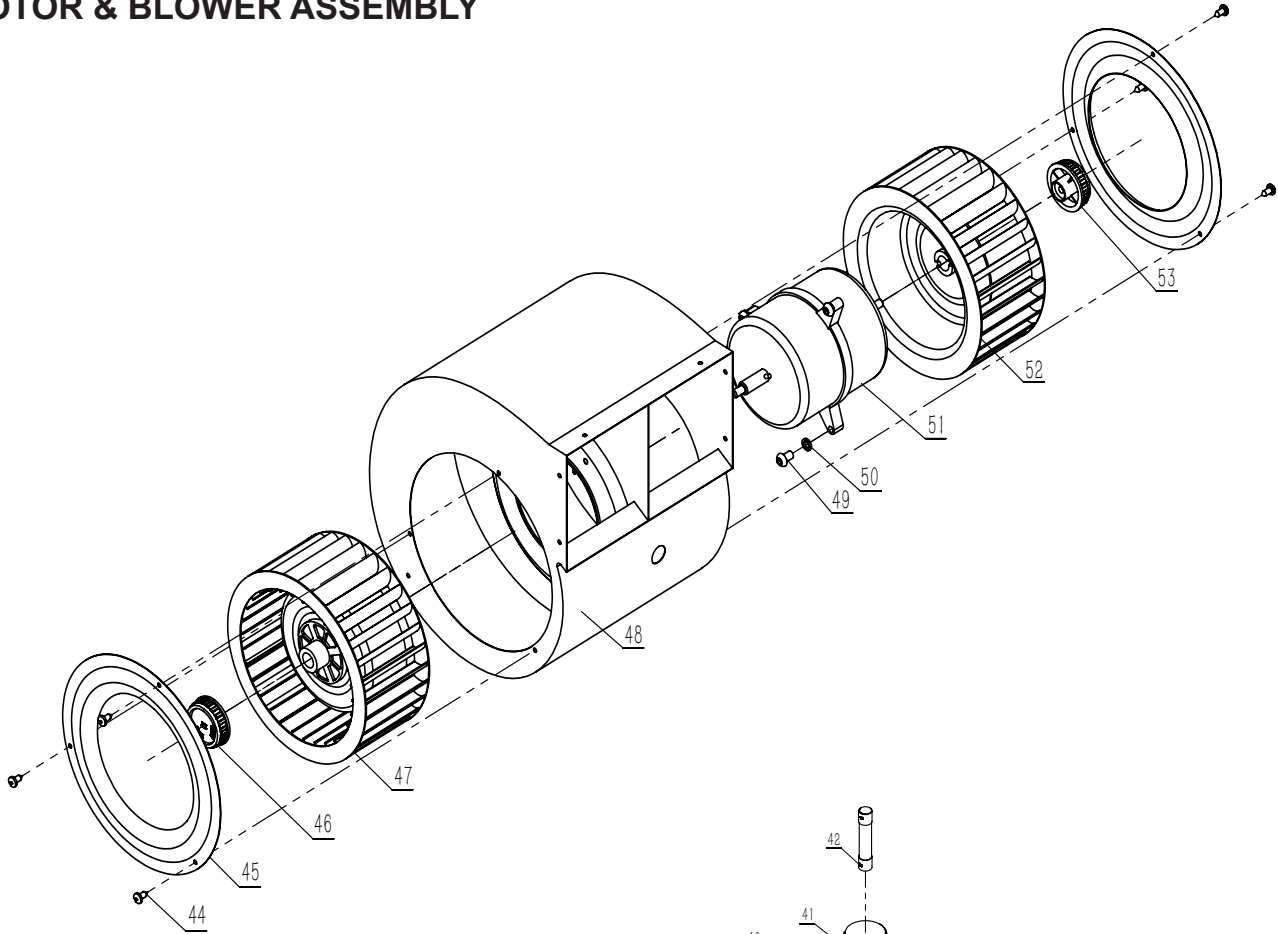

CONTROL PANEL ASSEMBLY

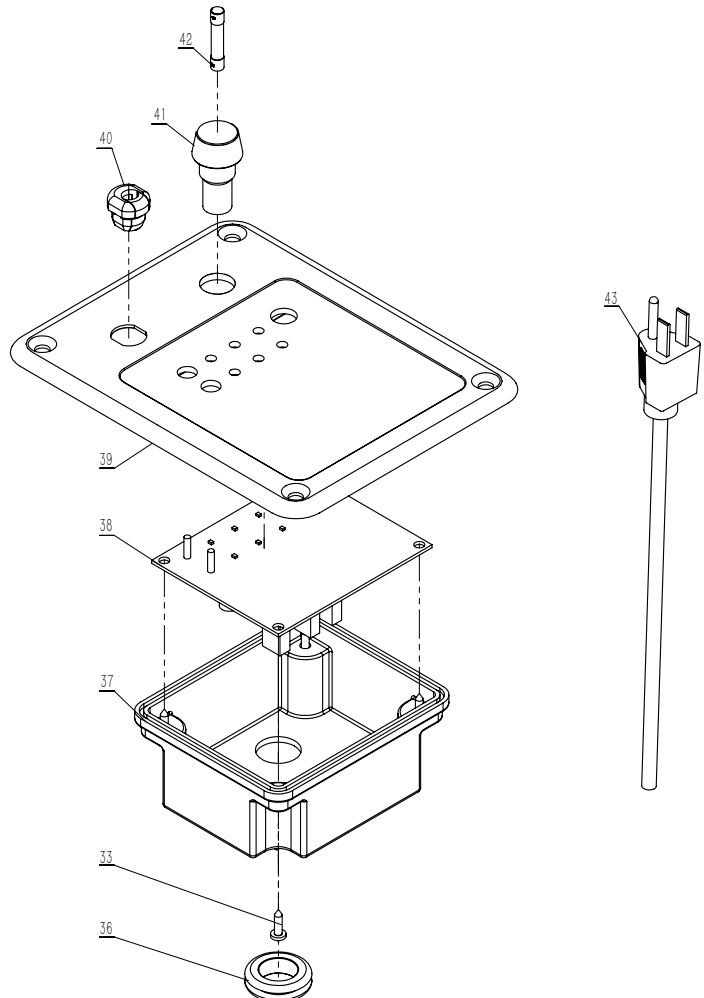

NOTE: Please reference the Manufacturer's Part Number when calling for Replacement Parts. For Parts under Warranty, the Serial Number of your machine is required.

PARTS LIST

Key No.	Description	QTY	MFG. PART NO.
1	Cross Recessed Countersunk Head Screw M6x20	4	P62-450-1
2	Switch	1	P62-450-2
3	Flat Washer	8	P62-450-3
4	Spring Washer	8	P62-450-4
5	Cross Recessed Countersunk Head Screw M4X10	8	P62-450-5
6	Hex Nut	7	P62-450-6
7	Spring Washer	7	P62-450-7
8	Flat Washer	7	P62-450-8
9	Cross Recessed Countersunk Head Screw M5x16	13	P62-450-9
10	Mounted Plate	1	P62-450-10
11	Air Blower	1	P62-450-11
12	Hand Ring	4	P62-450-12
13	Hex Nut with Flange M6	4	P62-450-13
14	Hook Screw	4	P62-450-14
15	Key Chain	4	P62-450-15
16	Lifting Chain	4	P62-450-16
17	S-Hook	4	P62-450-17
18	Cross Recessed Countersunk Head Screw M6X16	4	P62-450-18
19	Frame	1	P62-450-19
20	Handle	1	P62-450-20
21	Protective Screening	1	P62-450-21
22	Big Washer	10	P62-450-22
23	Cross Recessed Pan Head Tapping Screw	10	P62-450-23
24	Plate Filter	1	P62-450-24
25	Bag Filter	1	P62-450-25
26	Filter Block Slice	2	P62-450-26
27	Baffle Base	2	P62-450-27
28	Self-Plugging Rivet	6	P62-450-28
29	Rubber Plug	4	P62-450-29
30	Panel Component	1	P62-450-30
31	Fixed Plate	1	P62-450-31
32	Locking Washer	1	P62-450-32
33	Cross Recessed Pan Head Tapping Screw	5	P62-450-33
34	Capacitor	1	P62-450-34
35	Remote Control	1	P62-450-35
36	Rubber Bushing	1	P62-450-36
37	Electrical Box	1	P62-450-37
38	Circuit Board	1	P62-450-38
39	Electrical Installation Board	1	P62-450-39
40	Wire Clip	1	P62-450-40
41	Fuse Holder	1	P62-450-41
42	Fuse	1	P62-450-42
43	Three - Wire Plug Cable	1	P62-450-43
44	Cross Recessed Pan Head Tapping Screw	6	P62-450-44
45	Ventilating Ring	2	P62-450-45
46	Left Turbine Cap	1	P62-450-46
47	Left Turbine Wheel	1	P62-450-47
48	Blower Housing	1	P62-450-48
49	Hex socket button head screw M6X10	3	P62-450-49
50	Spring washer	4	P62-450-50
51	Motor 120v	1	P62-450-51
52	Right Turbine Wheel	1	P62-450-52
53	Right Turbine Cap	1	P62-450-53

ACCESSORIES



61-911F Outer Filter

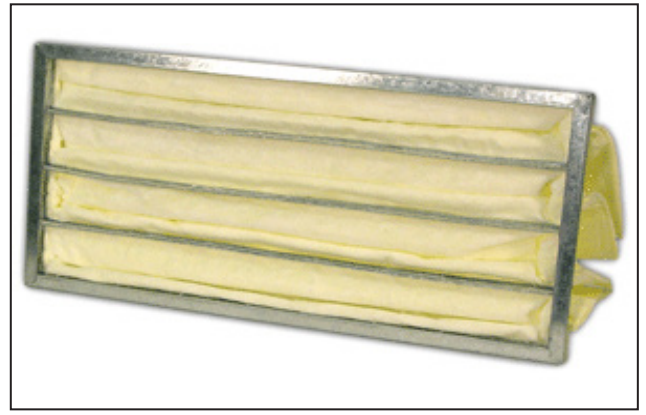

61-905 Inner Filter

See page two "SPECIFICATIONS" for filter sizes

WARRANTY

RIKON
POWER TOOLS®

5-Year Limited Warranty

RIKON Power Tools Inc. ("Seller") warrants to only the original retail consumer/purchaser of our products that each product be free from defects in materials and workmanship for a period of five (5) years from the date the product was purchased at retail. This warranty may not be transferred.

This warranty does not apply to defects due directly or indirectly to misuse, abuse, negligence, accidents, repairs, alterations, lack of maintenance or normal wear and tear. Under no circumstances will Seller be liable for incidental or consequential damages resulting from defective products. All other warranties, expressed or implied, whether of merchantability, fitness for purpose, or otherwise are expressly disclaimed by Seller. This five-year warranty does not cover products used for commercial, industrial or educational purposes. The warranty term for these claims will be limited to a two-year period.

This limited warranty does not apply to accessory items such as blades, drill bits, sanding discs, grinding wheels, belts, guide bearings and other related items.

Seller shall in no event be liable for death, injuries to persons or property, or for incidental, contingent, special, or consequential damages arising from the use of our products.

To take advantage of this warranty, proof of purchase documentation must be provided which has the date of purchase and an explanation of the complaint.

The Seller reserves the right to effect at any time, without prior notice, those alterations to parts, fittings, and accessory equipment which they may deem necessary for any reason whatsoever.

To register your machine online, visit RIKON at www.rikontools.com/warranty

To take advantage of this warranty, or if you have any questions, please contact us at 877-884-5167 or email warranty@rikontools.com

The RIKON website has information regarding your machine, its accessories, the full line of other RIKON machines, accessories, and a listing of authorized RIKON Distributors in your area.



**For more information:
25 Commerce Way
North Andover, MA 01845**

**877-884-5167 / 978-528-5380
techsupport@rikontools.com**