

Oscillating Spindle Sander



Operator's Manual

Record the serial number and date of purchase in your manual for future reference.

The serial number can be found on the specification label on the rear of your machine.

Serial Number: _____ Date of purchase: _____

For technical support, email techsupport@rikontools.com - For parts questions, email parts@rikontools.com

TABLE OF CONTENTS

Specifications	2
Safety Warnings.....	3-6
Electrical Requirements	5 & 18
Sander Safety Rules	6
Contents of Package	7
Getting to Know Your Machine	8
Assembly/Adjustments.....	8-10
Operation.....	11-12
Maintenance.....	13
Troubleshooting.....	13
Parts Diagrams & Parts Lists.....	14-17
Wiring Diagram.....	18
Accessories	18
Notes	18
Warranty	19

SPECIFICATIONS

Motor	1/2 HP, 370 W, 3.4 A, 110V, 60 Hz
Speed (no load)	1,700 RPM
Table Size (LxW)	14-3/4" x 14-3/4"
Table Tilt	0° to 45° forward
Spindle Length	4-1/2" (115mm)
Spindle Diameters Included (5)	1/2", 3/4", 1", 1-1/2", 2"
Maximum Spindle Diameter Allowed	3" (available separately)
Spindle Oscillation	24mm (15/16")
Oscillations Per Minute	29
Dust Outlet	50mm (1-3/4" I.D. or 2" O.D.)
Height (overall)	23-1/2"
Height (base to table)	19"
Width	17-1/4"
Depth	14-3/4"
Base Size (LxW)	11-13/16" x 11"
Sound Power Level	78 - 80.1 dB
Sound Pressure Level	69.6 - 65.9 dB
Net Weight	76 Lbs.
Shipping Weight	80 Lbs.
Shipping Carton	15-1/2" x 15-1/2" x 19-1/8"

NOTE: The specifications, photographs, drawings and information in this manual represent the current model when the manual was prepared. Changes and improvements may be made at any time, with no obligation on the part of Rikon Power Tools, Inc. to modify previously delivered units. Reasonable care has been taken to ensure that the information in this manual is correct, to provide you with the guidelines for the proper safety, assembly and operation of this machine.

SAFETY INSTRUCTIONS

IMPORTANT! Safety is the single most important consideration in the operation of this equipment. **The following instructions must be followed at all times.** Failure to follow all instructions listed below may result in electric shock, fire, and/or serious personal injury.

There are certain applications for which this tool was designed. We strongly recommend that this tool not be modified and/or used for any other application other than that for which it was designed. If you have any questions about its application, do not use the tool until you have contacted us and we have advised you.

SAFETY SYMBOLS



SAFETY ALERT SYMBOL: Indicates DANGER, WARNING, or CAUTION. This symbol may be used in conjunction with other symbols or pictographs.



Indicates an imminently hazardous situation, which, if not avoided, could result in death or serious injury.



Indicates a potentially hazardous situation, which, if not avoided, could result in death or serious injury.



Indicates a potentially hazardous situation, which, if not avoided, could result in minor or moderate injury.

NOTICE: Shown without Safety Alert Symbol indicates a situation that may result in property damage.

GENERAL SAFETY

KNOW YOUR POWER TOOL. Read the owner's manual carefully. Learn the tool's applications, work capabilities, and its specific potential hazards.

BEFORE USING YOUR MACHINE

To avoid serious injury and damage to the tool, read and follow all of the Safety and Operating Instructions before operating the machine.

1. **WARNING:** Some dust created by using power tools contains chemicals known to the State of California to cause cancer, birth defects, or other reproductive harm. Some examples of these chemicals are:

- Lead from lead-based paints.
- Crystalline silica from bricks, cement, and other masonry products.
- Arsenic and chromium from chemically treated lumber.

Your risk from these exposures varies, depending on how often you do this type of work. To reduce your exposure to these chemicals: work in a well ventilated area and work with approved safety equipment, such as those dust masks that are specially designed to filter out microscopic particles.

2. **READ** the entire Owner's Manual. **LEARN** how to use the tool for its intended applications.

3. **GROUND ALL TOOLS.** If the tool is supplied with a 3 prong plug, it must be plugged into a 3-contact electrical receptacle. The 3rd prong is used to ground the tool and provide protection against accidental electric shock. **DO NOT** remove the 3rd prong. See Grounding Instructions on the following pages.

4. **AVOID A DANGEROUS WORKING ENVIRONMENT.** **DO NOT** use electrical tools in a damp environment or expose them to rain.

5. **DO NOT** use electrical tools in the presence of flammable liquids or gases.

6. **ALWAYS** keep the work area clean, well lit, and organized. **DO NOT** work in an environment with floor surfaces that are slippery from debris, grease, and wax.

7. **KEEP VISITORS AND CHILDREN AWAY. DO NOT** permit people to be in the immediate work area, especially when the electrical tool is operating.

8. **DO NOT FORCE THE TOOL** to perform an operation for which it was not designed. It will do a safer and higher quality job by only performing operations for which the tool was intended.

9. **WEAR PROPER CLOTHING. DO NOT** wear loose clothing, gloves, neckties, or jewelry. These items can get caught in the machine during operations and pull the operator into the moving parts. The user must wear a protective cover on their hair, if the hair is long, to prevent it from contacting any moving parts.

10. **CHILDPROOF THE WORKSHOP AREA** by removing switch keys, unplugging tools from the electrical receptacles, and using padlocks.

11. **ALWAYS UNPLUG THE TOOL FROM THE ELECTRICAL RECEPTACLE** when making adjustments, changing parts or performing any maintenance.

SAFETY INSTRUCTIONS

12. KEEP PROTECTIVE GUARDS IN PLACE AND IN WORKING ORDER.

13. AVOID ACCIDENTAL STARTING. Make sure that the power switch is in the “OFF” position before plugging in the power cord to the electrical receptacle.

14. REMOVE ALL MAINTENANCE TOOLS from the immediate area prior to turning “ON” the machine.

15. USE ONLY RECOMMENDED ACCESSORIES. Use of incorrect or improper accessories could cause serious injury to the operator and cause damage to the tool. If in doubt, check the instruction manual that comes with that particular accessory.

16. NEVER LEAVE A RUNNING TOOL UNATTENDED. Turn the power switch to the “OFF” position. **DO NOT** leave the tool until it has come to a complete stop.

17. DO NOT STAND ON A TOOL. Serious injury could result if the tool tips over, or you accidentally contact the tool.

18. DO NOT store anything above or near the tool where anyone might try to stand on the tool to reach it.

19. MAINTAIN YOUR BALANCE. DO NOT extend yourself over the tool. Wear oil resistant rubber soled shoes. Keep floor clear of debris, grease, and wax.

20. MAINTAIN TOOLS WITH CARE. Always keep tools clean and in good working order. Keep all blades and tool bits sharp, dress grinding wheels and change other abrasive accessories when worn.

21. EACH AND EVERY TIME, CHECK FOR DAMAGED PARTS PRIOR TO USING THE TOOL. Carefully check all guards to see that they operate properly, are not damaged, and perform their intended functions. Check for alignment, binding or breaking of moving parts. A guard or other part that is damaged should be immediately repaired or replaced.

22. DO NOT OPERATE TOOL WHILE TIRED, OR UNDER THE INFLUENCE OF DRUGS, MEDICATION OR ALCOHOL.

23. SECURE ALL WORK. Use clamps or jigs to secure the work piece. This is safer than attempting to hold the work piece with your hands.

24. STAY ALERT, WATCH WHAT YOU ARE DOING, AND USE COMMON SENSE WHEN OPERATING A POWER TOOL.
A moment of inattention while operating power tools may result in serious personal injury.

25. ALWAYS WEAR A DUST MASK TO PREVENT INHALING DANGEROUS DUST OR AIRBORNE PARTICLES, including wood dust, crystalline silica dust and asbestos dust. Direct particles away from face and body. Always operate tool in well ventilated area and provide for proper dust removal. Use dust collection system wherever possible. Exposure to the dust may cause serious and permanent respiratory or other injury, including silicosis (a serious lung disease), cancer, and death. Avoid breathing the dust, and avoid prolonged contact with dust. Allowing dust to get into your mouth or eyes, or lay on your skin may promote absorption of harmful material. Always use properly fitting NIOSH/OSHA approved respiratory protection appropriate for the dust exposure, and wash exposed areas with soap and water.

26. USE A PROPER EXTENSION CORD IN GOOD CONDITION. When using an extension cord, be sure to use one heavy enough to carry the current your product will draw. The table on the following page shows the correct size to use depending on cord length and nameplate amperage rating. If in doubt, use the next heavier gauge. The smaller the gauge number, the larger diameter of the extension cord. If in doubt of the proper size of an extension cord, use a shorter and thicker cord. An undersized cord will cause a drop in line voltage resulting in a loss of power and overheating.
USE ONLY A 3-WIRE EXTENSION CORD THAT HAS A 3-PRONG GROUNDING PLUG AND A 3-POLE RECEPTACLE THAT ACCEPTS THE TOOL’S PLUG.

27. ADDITIONAL INFORMATION regarding the safe and proper operation of this product is available from:

- Power Tool Institute
1300 Summer Avenue
Cleveland, OH 44115-2851
www.powertoolinstitute.org
- National Safety Council
1121 Spring Lake Drive
Itasca, IL 60143-3201
www.nsc.org
- American National Standards Institute
25 West 43rd Street, 4th Floor
New York, NY 10036
www.ansi.org
- ANSI 01.1 Safety Requirements for Woodworking Machines and the U.S. Department of Labor regulations
www.osha.gov

28. SAVE THESE INSTRUCTIONS. Refer to them frequently and use them to instruct others.

SAFETY INSTRUCTIONS

ELECTRICAL SAFETY

⚠️ WARNING: THIS TOOL MUST BE GROUNDED WHILE IN USE TO PROTECT THE OPERATOR FROM ELECTRIC SHOCK.

IN THE EVENT OF A MALFUNCTION OR BREAKDOWN, grounding provides the path of least resistance for electric current and reduces the risk of electric shock. This tool is equipped with an electric cord that has an equipment grounding conductor and requires a grounding plug (not included). The plug **MUST** be plugged into a matching electrical receptacle that is properly installed and grounded in accordance with **ALL** local codes and ordinances.

DO NOT MODIFY ANY PLUG. If it will not fit the electrical receptacle, have the proper electrical receptacle installed by a qualified electrician.

IMPROPER ELECTRICAL CONNECTION of the equipment grounding conductor can result in risk of electric shock. The conductor with the green insulation (with or without yellow stripes) is the equipment grounding conductor. **DO NOT** connect the equipment grounding conductor to a live terminal if repair or replacement of the electric cord or plug is necessary.

CHECK with a qualified electrician or service personnel if you do not completely understand the grounding instructions, or if you are not sure the tool is properly grounded when installing or replacing a plug.

USE ONLY A 3-WIRE EXTENSION CORD THAT HAS THE PROPER TYPE OF A 3-PRONG GROUNDING PLUG THAT MATCHES THE MACHINE'S 3-PRONG PLUG AND ALSO THE 3-POLE RECEPTACLE THAT ACCEPTS THE TOOL'S PLUG. *

REPLACE A DAMAGED OR WORN CORD IMMEDIATELY.

This tool is intended for use on a circuit that has an electrical receptacle as shown in **FIGURE A**. It shows a 3-wire electrical plug and electrical receptacle that has a grounding conductor. If a properly grounded electrical receptacle is not available, an adapter as shown in **FIGURE B** can be used to temporarily connect this plug to a 2-contact ungrounded receptacle. The adapter has a rigid lug extending from it that **MUST** be connected to a permanent earth ground, such as a properly grounded receptacle box. **THIS ADAPTER IS PROHIBITED IN CANADA.**

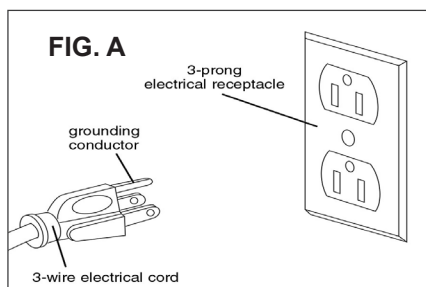

EXTENSION CORDS

⚠️ WARNING: THE USE OF AN EXTENSION CORD WITH THIS MACHINE IS NOT RECOMMENDED. For best power and safety, plug the machine directly into a dedicated, grounded electrical outlet that is within the supplied cord length of the machine.

If an extension cord needs to be used, it should only be for a limited operation of the machine. The extension cord should be as short as possible in length, and have a minimum gauge size of 14AWG.

⚠️ WARNING: Check extension cords before each use. If damaged replace immediately. Never use a tool with a damaged cord, since touching the damaged area could cause electrical shock, resulting in serious injury.

Use a proper extension cord. Only use cords listed by Underwriters Laboratories (UL). Other extension cords can cause a drop in line voltage, resulting in a loss of power and overheating of tool. When operating a power tool outdoors, use an outdoor extension cord marked "W-A" or "W". These cords are rated for outdoor use and reduce the risk of electric shock.

MINIMUM RECOMMENDED GAUGE FOR EXTENSION CORDS (AWG)

120 VOLT OPERATION ONLY				
	25' LONG	50' LONG	100' LONG	150' LONG
0 to 6 Amps	18 AWG	16 AWG	16 AWG	14 AWG
6 to 10 Amps	18 AWG	16 AWG	14 AWG	12 AWG
10 to 12 Amps	16 AWG	16 AWG	14 AWG	12 AWG

⚠️ WARNING: Keep the extension cord clear of the working area. Position the cord so that it will not get caught on lumber, tools or other obstructions while you are working with your power tool.

* Canadian electrical codes require extension cords to be certified SJT type or better.

** The use of an adapter in Canada is not acceptable.

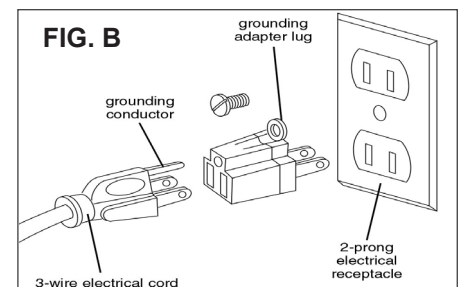

SAFETY INSTRUCTIONS

SPECIFIC SAFETY INSTRUCTIONS FOR SANDERS

This machine is intended for the surfacing of natural, solid woods and composite materials. Any other use not as specified, including modification of the machine or use of parts not tested and approved by the equipment manufacturer can cause unforeseen damage, and invalidate the warranty.

ATTENTION: Use of this sander still presents risks that cannot be eliminated by the manufacturer. Therefore, the user must be aware that wood working machines are dangerous if not used with care and all safety precautions are adhered to.

1. Do not operate this machine until you have read all of the following instructions.
2. Do not attempt to operate this machine until it is completely assembled.
3. Do not turn ON this machine if any pieces are missing.
4. This machine must be properly grounded.
5. If you are not familiar with the operation of the machine, obtain assistance from a qualified person.
6. It is highly recommended that this machine be mounted to a flat and secure work surface or stand.
7. Always wear protective eye wear and hearing protection when operating this machine.
8. Always wear a dust mask and use adequate dust collection and proper ventilation. Use of sanders can produce harmful particles while sanding certain types of woods, composites or plastics.
9. Do not operate this machine if you are under the influence of drugs, alcohol or medication.
10. Do not wear loose clothing or jewelry when operating this machine. Tie back long hair.
11. Do not wear any gloves while operating this machine.
12. Always make sure the power switch is in the OFF position prior to plugging in the machine.
13. Always make sure the power switch is in the OFF position and the machine is unplugged when doing any cleaning, assembly, setup operations, or when not in use.
14. The use of any accessories or attachments not recommended may cause injury to you and damage your machine.
15. Check the work piece for nails, screws or other materials that could tear or damage the sanding drums.
16. Sanding of metals is not recommended as sparks may ignite sawdust and wood shavings.
17. Sanding of fiberglass or similar materials is not recommended as particles can damage bearings.
18. Abrasive sanding drums should be the recommended diameter of the manufacturer.
19. Replace worn, frayed or torn abrasives as injury to the user, or the machine, may result.
20. Always keep your face and hands clear of moving parts such as discs, belts and pulleys.
21. Keep power supply cords free of any sharp or moving parts. Damaged cords can result in electric shock.
22. Always support the workpiece with the table.
23. Remove material or debris from the work area. Keep work area neat and clean.

**SAVE THESE INSTRUCTIONS.
Refer to them often.**

**This owner's manual is not a teaching aid and is intended to show
assembly, adjustments, and general use.**

CONTENTS OF PACKAGE

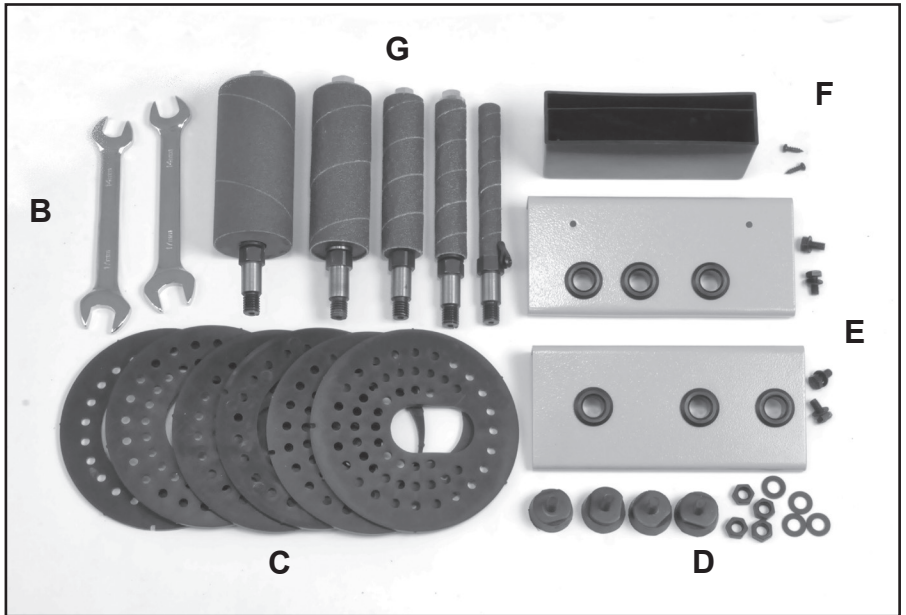
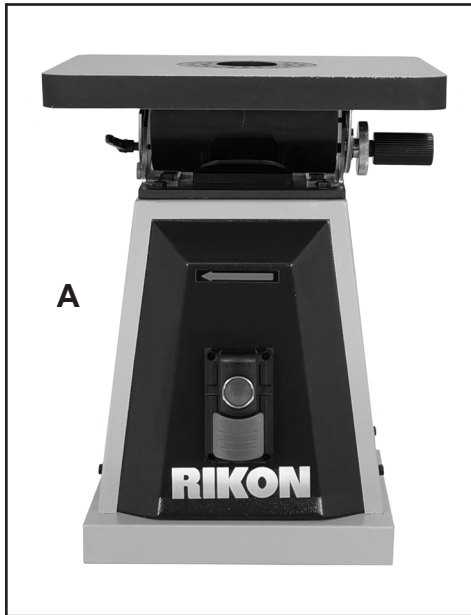

- | | | | |
|---|----------------------------|---|--|
| A | Sander | E | Tool Holders for Drums (2) & Hardware |
| B | Wrenches (2) - 14mm, 17mm | F | Holder for Table Inserts & Screws |
| C | Table Inserts (6) | G | Sanding Drums (5) - 1/2", 3/4", 1", 1-1/2", 2" |
| D | Rubber Feet (4) & Hardware | H | Manual & Warranty Card (not shown) |

UNPACKING AND CLEAN-UP

1. Carefully remove all contents from the shipping carton. Compare the contents with the list of contents to make sure that all of the items are accounted for, before discarding any packing material. Place parts on a protected surface for easy identification and assembly. If any parts are missing or broken, please call RIKON Customer Service (877-884-5167) as soon as possible for replacements. DO NOT turn your machine ON if any of these items are missing. You may cause injury to yourself or damage to the machine.
2. Report any shipping damage to your local distributor. Take photographs for any possible insurance claims.
3. Clean all rust protected surfaces with ordinary house hold type grease or spot remover. Do not use; gasoline, paint thinner, mineral spirits, etc. These may damage painted surfaces.
4. Apply a coat of paste wax to the table to prevent rust. Wipe all parts thoroughly with a clean dry cloth.
5. Set packing material and shipping carton aside. Do not discard until the machine has been set up and is running properly.

CALIFORNIA PROPOSITION 65 WARNING

 **WARNING:** Drilling, sawing, sanding or machining wood products can expose you to wood dust, a substance known to the State of California to cause cancer. Avoid inhaling wood dust or use a dust mask or other safeguards for personal protection. For more information go to www.P65Warnings.ca.gov/wood

GETTING TO KNOW YOUR MACHINE

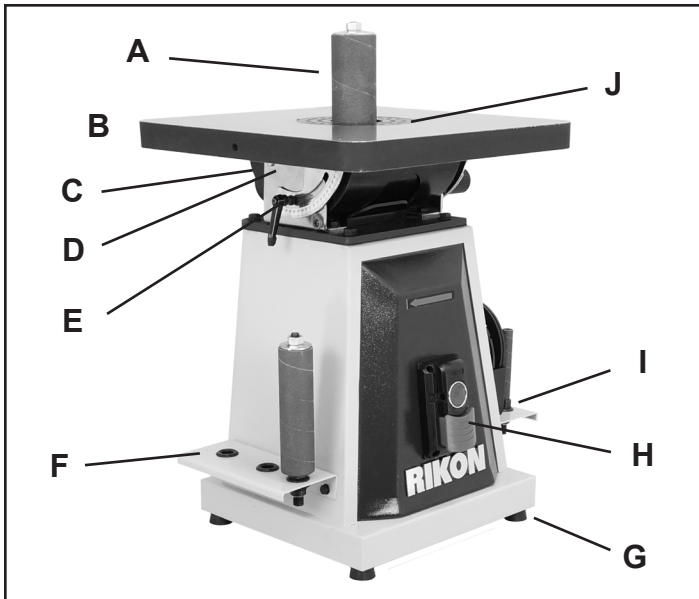

- A Spindle with Sanding Sleeve
- B Work Table
- C Dust Port
- D Cam for Table Leveling
- E Table Angle Scale and Locking Handle
- F Holder for Spindles
- G Rubber Feet (4)

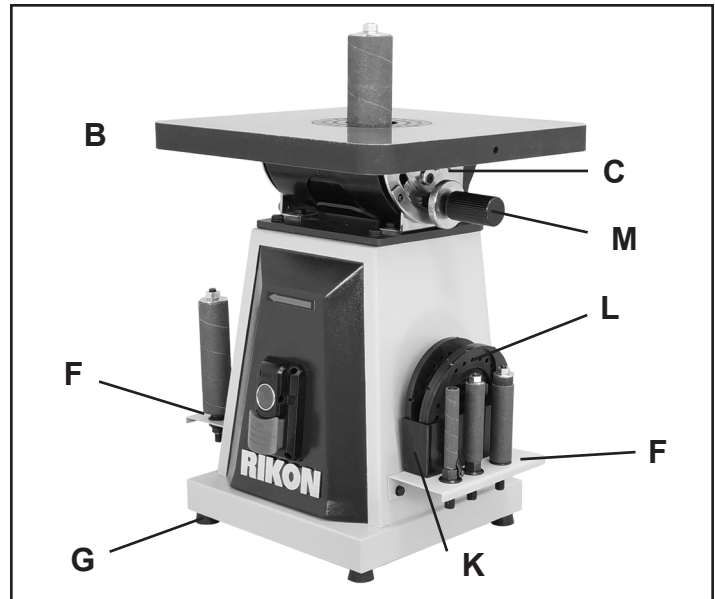

- H ON / OFF Safety Switch
- I Holder for Spindles
- J Table Insert (installed in table)
- K Holder for Table Inserts
- L Table Inserts
- M Geared Handle with Lock for Tilting Table

ASSEMBLY

NOTE: Pending packaging changes at the factory, some parts may already be pre-assembled on the machine. The assembly steps listed should none-the-less be reviewed for information on the machine parts and their adjustments.

ATTACH THE RUBBER FEET

1. Lower the machine onto its side to access the four holes in the bottom corners of the base.
2. Insert the treaded portion of the rubber foot through the machine's base, and put on a washer, followed by a nut to secure the foot in place. (Parts #A52 - 49). Figure 1.
3. Install the remaining three rubber feet and then raise the machine to its operating position. The rubber feet will prevent the machine from slipping on your bench during use, and reduce any vibration that may result from sanding operations.

POSITION THE SANDER ON A WORKBENCH

The sander must be positioned where it is to be used on a sturdy workbench, at a suitable, safe height for your sanding operations to be carried out.

TOOLS REQUIRED FOR ASSEMBLY

- #2 Phillips Screwdriver
- 4mm Hex Wrench
- 10mm & 13mm or an Adjustable Wrench

WARNING THE MACHINE MUST NOT BE PLUGGED IN AND THE POWER SWITCH MUST BE IN THE OFF POSITION UNTIL ALL ADJUSTMENTS ARE COMPLETE.

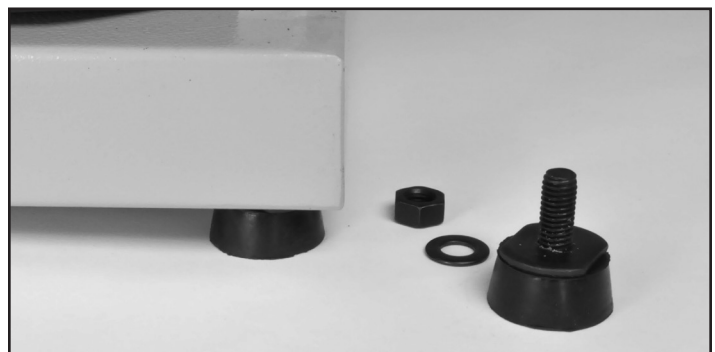

FIG. 1

CAUTION THE MACHINE IS HEAVY AND MAY REQUIRE TWO PERSONS FOR LIFTING

ASSEMBLY

INSTALL SANDPAPER ONTO THE SPINDLES

The sander is supplied with 5 rubber cylinder Spindles, 1/2", 3/4", 1", 1-1/2" and 2" diameters, that will hold sandpaper sleeves of various grits.

The Spindle consists of a rubber body with a metal axle passing through the center (Fig. 2). The axle has a key which locates into a key way in the rubber body. Normally these should need not be disturbed unless the rubber body is damaged.

At either end of the body are two large compression washers. At the top is a nut and washer to secure the cylindrical sandpaper. The low part of the axle is threaded, which locates into the motor drive.

1. To remove a sandpaper sleeve from a spindle, take off the top nut with a wrench, remove the washer, and slide the sleeve off of the rubber spindle. Fig. 3. **NOTE:** If removal was difficult sprinkle a small amount of talcum powder onto the rubber to aid fitting the new sandpaper sleeve.

2. To install a new sandpaper sleeve onto a spindle, slide the sleeve onto the rubber body so that it fits centrally with no edge overhanging.

3. Replace the washer and top nut. Tighten the nut to expand the rubber body. This will grip the sanding drum. Figure 3. **NOTE:** Do not over-tighten as this will distort rubber body.

NOTE: If the lower portion of the sanding sleeve is used, turn the sleeve over to use the upper section.

INSTALL THE SPINDLE ONTO THE MACHINE

1. Lower the spindle down through the table's center hole, and insert the spindle's threaded end into the open end of the motor drive spindle.

2. Turn the sanding spindle *counter-clockwise* with your hand to thread and install the sanding spindle into the motor drive spindle.

3. With the two supplied open ended wrenches, tighten the spindle in place. With one wrench hold the motor drive spindle and with the other wrench tighten the sander spindle. Do not over-tighten. Figure 4.

To remove a spindle, remove the table insert and reverse the process outlined above.

NOTE: Spindle installation is easiest if the machine's oscillation stops at the most upward, highest setting. Tilting the table also allows best access for wrenches.

⚠ WARNING THE MACHINE MUST NOT BE PLUGGED IN AND THE POWER SWITCH MUST BE IN THE OFF POSITION UNTIL ALL ADJUSTMENTS ARE COMPLETE.

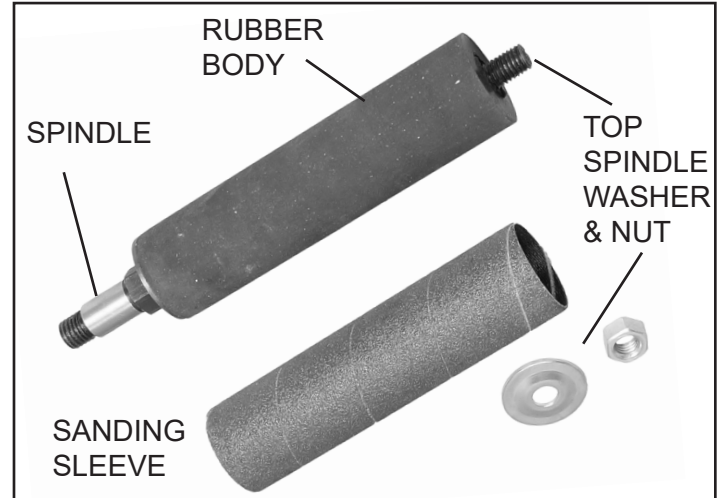

FIG. 2

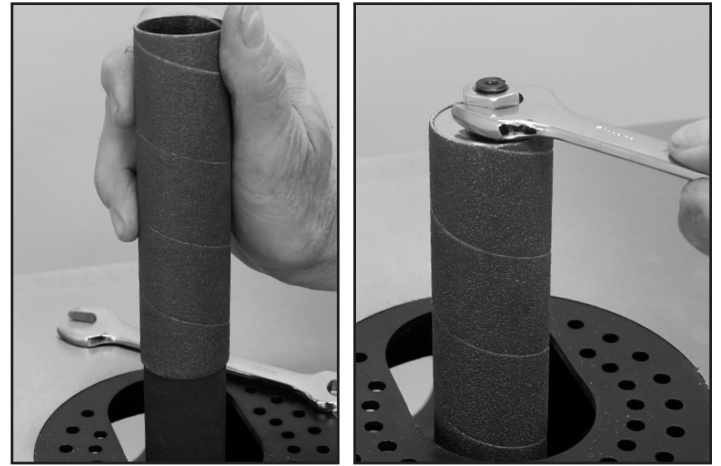

FIG. 3



FIG. 4

ASSEMBLY

INSTALL THE TABLE INSERT

The 50-300 Spindle Sander comes with a variety of Table Inserts, each with a different center hole diameter to be used with the matching spindle size.

NOTE: ALWAYS use a table insert when sanding.

One style has a round center hole for sanding with the table in the 90° position. The second style insert has an oval center hole for use when the table is tilted at an angle for sanding. This oval hole protects the insert from being damaged/sanded during operation.

To install an insert into the table, notice the cutout on the edge of the insert. This aligns with the peg in the recess on the table (Fig. 5). Lower the insert into position, making sure that the insert locates in the recess and is flush with the table.

To remove a table insert, simply push it out of the table with your finger from underneath.

ALIGN THE TABLE 90° TO THE SPINDLE

The table has the ability to tilt between 90° to 45°, (0° to -45°). Before the sander is used for the first time, squaring the table to the spindle setting needs to be checked.

1. Loosen the table locking Handle & Ring (# 9A,12A) and move the table into the 90-degree position with the Rotation Handle (#23A). Lightly tighten the table in place so that tilting adjustments can be made.

2. Using a 90° square placed on the table top, move the square to the spindle. It should measure 90°. (Fig. 6). If the table is not square to the spindle, an adjustment can be made to the table setting.

3. Located under the work table are two stop Cams (#21A) on either side of the Table Brackets (#2A, 3A) which can be adjusted to level the table (Fig. 7). With a 4mm hex wrench, loosen the cam's center Hex Nuts (#22A) to rotate the cams to raise or lower the table setting. When the table to spindle angle is at 90°, tighten the hex nuts to lock the stop cams in position.

4. Check the pointer and table angle scale setting to confirm that it is properly set to show the table angle is at 90° (0°). With a #2 Phillips screwdriver, loosen the pointer screw, align the pointer with the 0° position on the scale, and then re-tighten screw. Figure. 7.

⚠ WARNING THE MACHINE MUST NOT BE PLUGGED IN AND THE POWER SWITCH MUST BE IN THE OFF POSITION UNTIL ALL ADJUSTMENTS ARE COMPLETE.

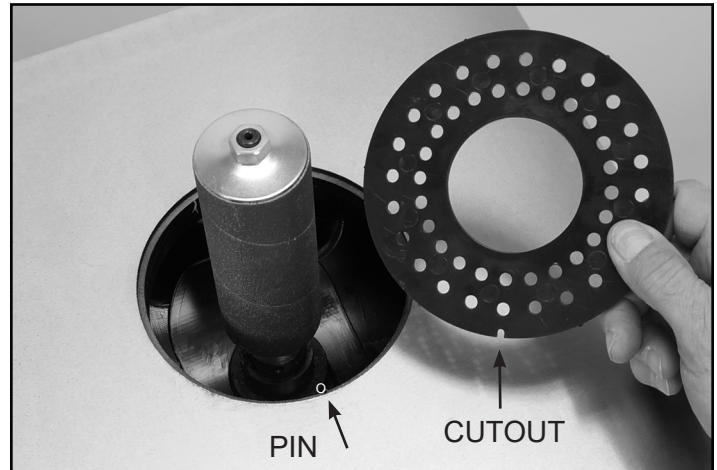

FIG. 5

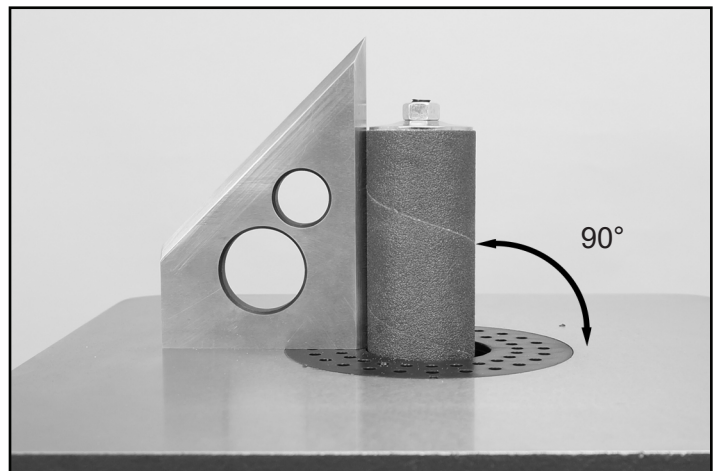

FIG. 6

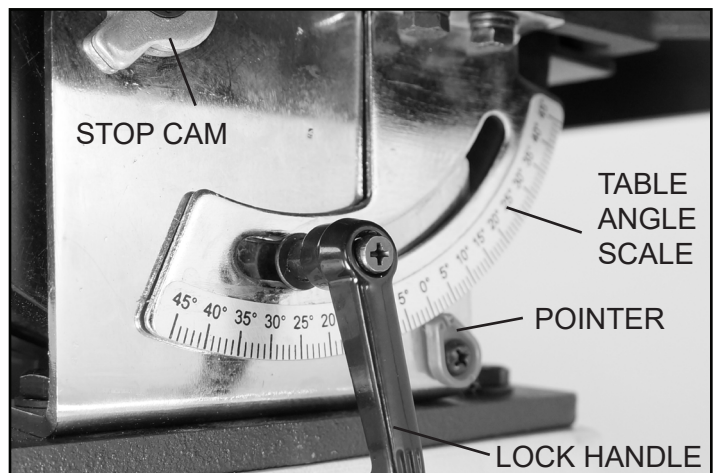

FIG. 7

OPERATION

TILTING THE TABLE

NOTE: Remove the table insert with the round cutout before tilting the table otherwise it will hit the spindle and break.

1. Loosen the side lever handle (#9A) and Ring (#12A) so that the table can be tilted.
2. The table will tilt 0° - 45°. Using the angle scale on the left side of the machine, once the desired table angle has been reached, tighten the locking handle and ring.
3. Locate the table insert with the oval cutout and place it into the table top. Figure 8.

ON/OFF SWITCH

The ON/OFF safety switch is located on the front of the sander for quick, easy and safe access. Push the top green button (A) to turn the machine on. Push the lower red paddle pad (B) to turn the drill press OFF. Figure 9.

Behind the ON button is a through hole for locking out the controls with a padlock that has a long hasp, thus preventing unauthorized use of the machine.

CAUTION: Never walk away from sander when machine is running. Always lock the switch in the Off position and unplug from the power supply when not in use.

USING THE OSCILLATING SPINDLE SANDER

1. Start the machine and wait until the motor has build up to full speed. The 50-300 Sander features a spindle that automatically oscillates (moves up and down) 24mm (15/16"). This movement ensures that the spindle's sandpaper gets maximum sanding use along the sleeve, and not wear in just one area.

CAUTION NEVER START THE MACHINE WITH WORK IN CONTACT WITH THE SPINDLE

2. Looking from the front of the machine, the motor turns in a clockwise direction. Feed the work across and with the direction of the spindle rotation. Fig. 10.

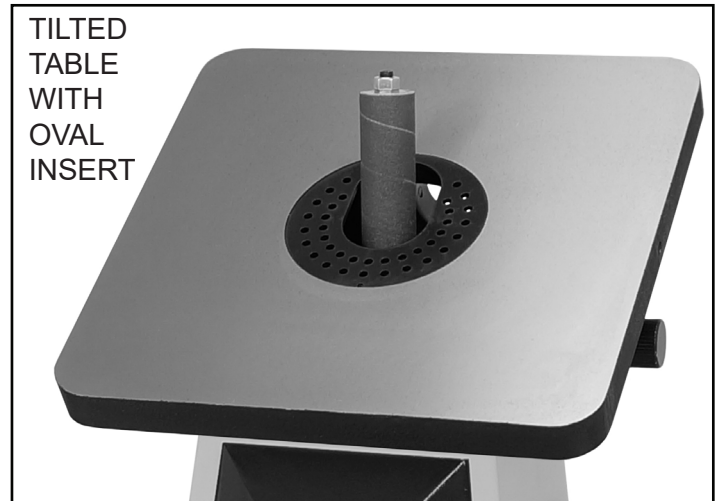

FIG. 8

WARNING THE MACHINE MUST NOT BE PLUGGED IN AND THE POWER SWITCH MUST BE IN THE OFF POSITION UNTIL ALL ADJUSTMENTS ARE COMPLETE.



FIG. 9

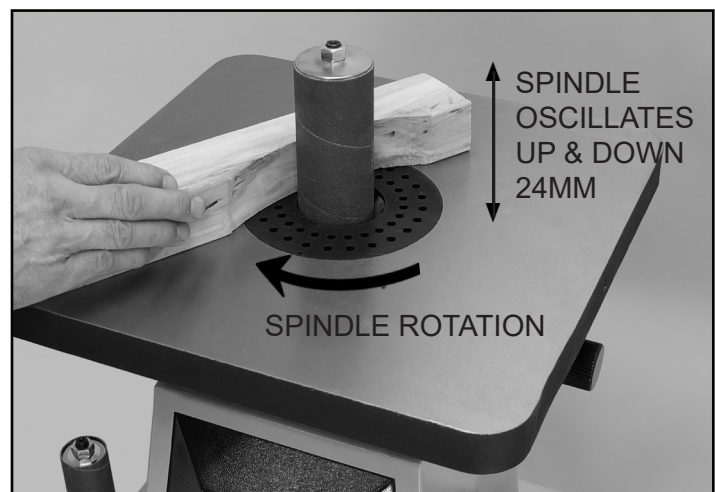

FIG. 10

OPERATION

CONTINUED FROM PAGE 11

3. NEVER feed the work into the machine and stand with your body directly behind it. The machine could force the work into the operator and cause serious injury.

USING THE SANDER AT ANGLES 0° - 45°

1. Take out the round insert and store carefully. Put in the oval insert (refer to selecting table insert, page 10) Slacken the table securing knobs either side of the machine.
2. Tilt the table to the desired angle and re-tighten the locking knobs.
3. Feed the work into the machine always with the direction of rotation. Figure 11.

NOTE: When the table is tilted to a particular angle, the same angle in sanding will only remain constant if the workpiece is run parallel to the spindle.

DUST EXTRACTION

This machine is fitted with a 50mm diameter dust extraction outlet. This is located at the rear of the machine directly under the table. Figure 12.

Attach your shop's dust collector hose to this dust port to collect the dust produced while sanding.

CAUTION DO NOT operate the sander without a dust collector and wear a protective dust mask. Sanding creates substantial amounts of dust which can be harmful to your respiratory system!

WARNING Before turning on the machine, review the safety precautions listed on pages 3 to 6. Make sure that you fully understand the features, adjustments and capabilities of the machine that are outlined throughout this manual.



FIG. 11



FIG. 12

For RIKON Dust Collectors and Accessories contact your local RIKON Tool Distributor, or visit www.rikontools.com for more information.



CALIFORNIA PROPOSITION 65 WARNING: Some dust created by power sanding, sawing, grinding, drilling, and other construction activities contains chemicals known to the State of California to cause cancer and birth defects or other reproductive harm. Your risk from exposure to these chemicals varies, depending on how often you do this type of work. To reduce your exposure, work in a well-ventilated area and with approved safety equipment, such as dust masks that are specially designed to filter out microscopic particles.

For more detailed information about California Proposition 65 log onto rikontools.com.

MAINTENANCE

⚠ WARNING: Turn the power switch “OFF” and disconnect the plug from the outlet prior to adjusting or maintaining the sander. DO NOT attempt to repair or maintain the electrical components of the motor. Take the sander to a qualified service technician for this type of maintenance.

MAINTENANCE REQUIRED

- | | | |
|----|--|------------------|
| 1. | Check the power cord and plug for any damage. | Before each use. |
| 2. | Check sanding spindles and sleeves for damage or wear. | Before each use. |
| 3. | Check all guards and hardware to make sure they are secure. | Before each use. |
| 4. | Check all moving parts for alignment and binding issues. | Before each use. |
| 5. | Dress/Clean sanding surfaces for best abrasive action. | As needed |
| 6. | Replace sanding sleeves when worn or damaged. | As needed. |
| 7. | Clean and vacuum dust from the motor housing and other sander parts. | As needed. |
| 8. | Keep iron tables free of rust. Apply coat of paste wax or silicon spray. | As needed. |

FREQUENCY

NOTE: Lubrication of the bearings is not necessary, as they are sealed and pre-lubricated for life. Just replace a bearing if failure occurs. Do not use compressed air near bearings. Simply wipe the exposed bearing surfaces with a dry cloth to clean them.

WARNING: If blowing sawdust, wear proper eye protection to prevent debris from blowing into eyes.

Service beyond recommended maintenance on these tools should only be performed by an authorized, qualified technician.

TROUBLESHOOTING

PROBLEM	POSSIBLE CAUSE	SOLUTION
Sander will not start	<ol style="list-style-type: none"> 1. Sander unplugged from wall or motor 2. Fuse blown or circuit breaker tripped 3. Cord is damaged 	<ol style="list-style-type: none"> 1. Check all plug connections 2. Replace fuse or reset circuit breaker 3. Replace the cord
Sander does not come up to speed	<ol style="list-style-type: none"> 1. Extension cord is too light or too long 2. Low current 	<ol style="list-style-type: none"> 1. Replace with adequate size and length of cord 2. Contact a qualified electrician
Machine vibrates excessively	<ol style="list-style-type: none"> 1. Work table or base is on an uneven surface 	<ol style="list-style-type: none"> 1. Adjust the table or base so that it rests evenly 2. Bolt down the machine
Sanded edge is not square	<ol style="list-style-type: none"> 1. Table not square to the spindle 	<ol style="list-style-type: none"> 1. Use a square to adjust the table to the spindle
Sanding marks on the wood	<ol style="list-style-type: none"> 1. Workpiece is held still 2. Wrong grit of sanding sleeve 3. Feed pressure is too great 4. Sanding against the wood grain 	<ol style="list-style-type: none"> 1. Keep the workpiece moving 2. Use coarser grit for stock removal, fine grit for finish sanding 3. Never force the workpiece 4. Sand with the grain

PARTS DIAGRAM

50-300 OSCILLATING SPINDLE SANDER

DIAGRAM A

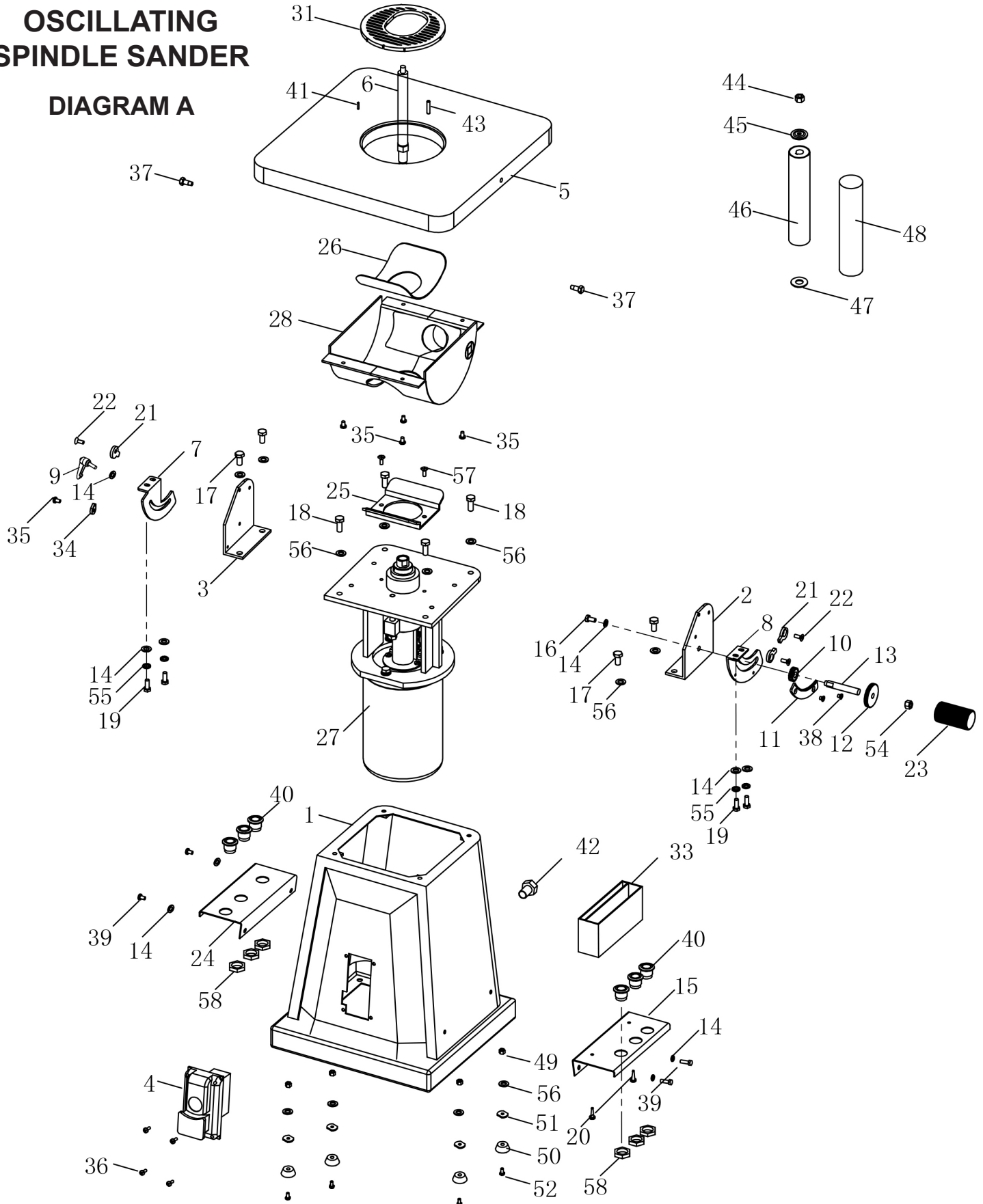

PARTS LIST

50-300 OSCILLATING SPINDLE SANDER

DIAGRAM A

KEY NO.	DESCRIPTION	PART NO.	KEY NO.	DESCRIPTION	PART NO.
1A	Machine body	P50-300-1A	31A	Insert for 1/2, 3/4, 1" spindles	50-4001
2A	Worktable bracket	P50-300-2A	31B	Insert 1-1/2, 1-3/4, 2" spindles	50-4002
3A	Worktable bracket	P50-300-3A	31C	Insert for 3" spindle	50-4003
4A	Switch	P50-300-4A	31D	Oval Insert 1/2, 3/4, 1" spindles	50-4004
5A	Work table	P50-300-5A	31E	Oval Insert 1-1/2, 1-3/4, 2" spndl	50-4005
6A	Connection rod	P50-300-6A	31F	Oval Insert for 3" spindle	50-4006
7A	Rotation bracket of table (Left)	P50-300-7A	33A	Tool holder for table inserts	P50-300-33A
8A	Rotation bracket of table (Right)	P50-300-8A	34A	Dial indicator	P50-300-34A
9A	Ratchet level	P50-300-9A	35A	Pan head screws M5x8	P50-300-35A
10A	Small gear	P50-300-10A	36A	Pan head screws M4x12	P50-300-36A
11A	Rack	P50-300-11A	37A	Stepped bolt	P50-300-37A
12A	Locking ring	P50-300-12A	38A	Countersunk screws M5x6	P50-300-38A
13A	Rotating shaft	P50-300-13A	39A	Hex bolt M6x12	P50-300-39A
14A	Washer 6	P50-300-14A	40A	Cone sleeve	P50-300-40A
15A	Right hand drum frame	P50-300-15A	41A	Spring pin 2.5x20	P50-300-41A
16A	Hex bolt M6x12	P50-300-16A	42A	Cable strain relief M18	P50-300-42A
17A	Hex bolt M8x16	P50-300-17A	43A	Key 5x50	P50-300-43A
18A	Hex bolt M8x20	P50-300-18A	44A	Left-handed nut M10	P50-300-44A
19A	Hex bolt M6x16	P50-300-19A	45A	Convex washer	P50-300-45A
20A	Tapping screws ST4.0x10	P50-300-20A	46A	Rubber sleeve	P50-300-46A
21A	Eccentric cam	P50-300-21A	47A	Washer	P50-300-47A
22A	Countersunk screws M6x12	P50-300-22A	48A	Sanding sleeve	P50-300-48A
23A	Rotation handle	P50-300-23A	49A	Hex nut M8	P50-300-49A
24A	Tool holder for sanding drums	P50-300-24A	50A	Rubber washer	P50-300-50A
25A	Fixed section	P50-300-25A	51A	Nut washer	P50-300-51A
26A	Movable section	P50-300-26A	52A	Hex bolt M8x25	P50-300-52A
27A	Oscillation assembly	P50-300-27A	54A	Hex nut M10	P50-300-54A
28A	Dust extraction housing/port	P50-300-28A	55A	Spring washer 6	P50-300-55A
			56A	Washer 8	P50-300-56A
			57A	Pan head screws M6x12	P50-300-57A
			58A	Cone sleeve nut	P50-300-58A

NOTE: Please reference the Manufacturer's Part Number when calling for Replacement Parts. For Parts under Warranty, the Serial Number of your machine is required.

PARTS DIAGRAM

50-300 OSCILLATING SPINDLE SANDER

DIAGRAM B

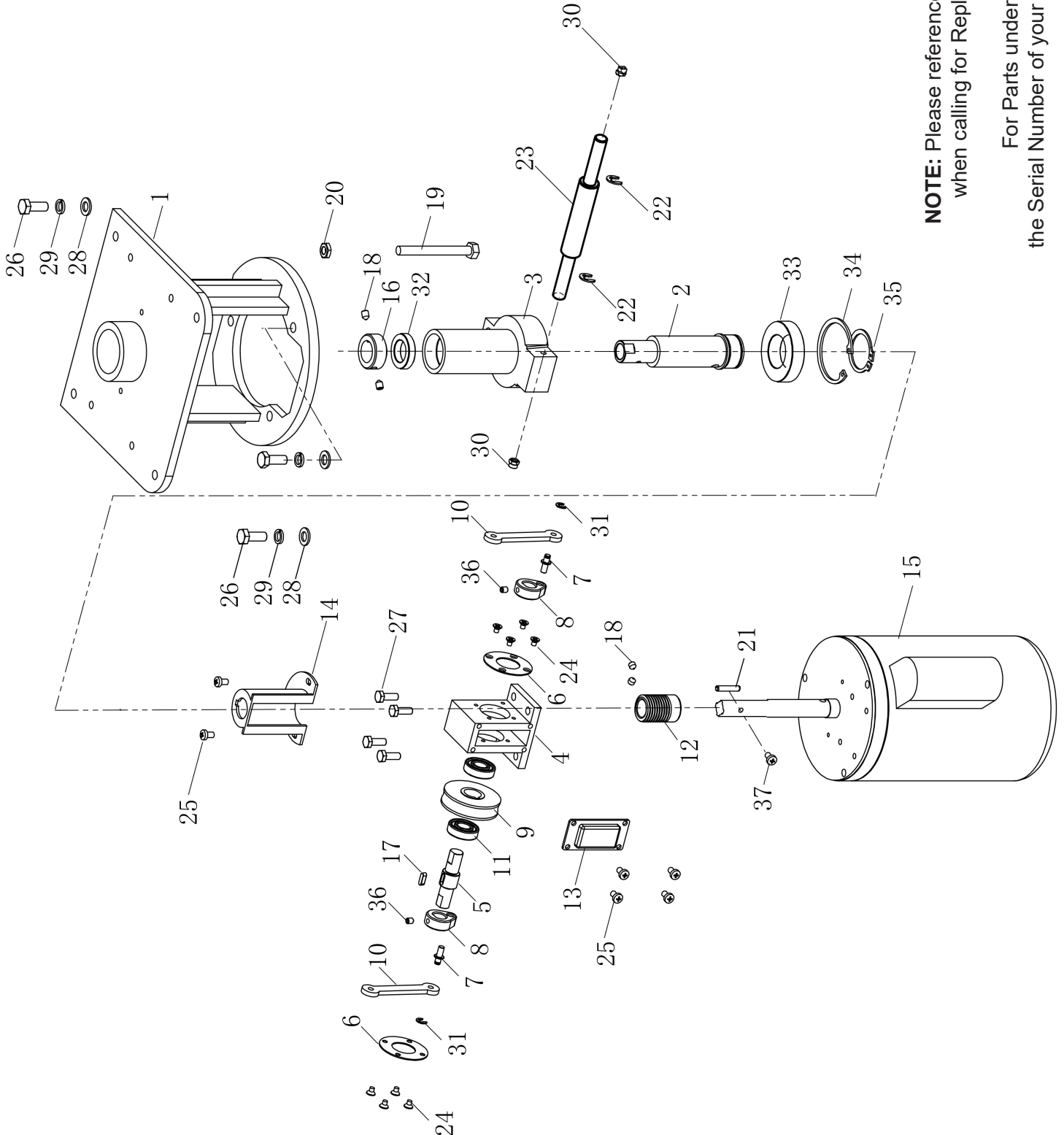

NOTE: Please reference the Key Number when calling for Replacement Parts.

For Parts under Warranty, the Serial Number of your machine is required.

PARTS LIST

KEY NO.	DESCRIPTION	PART NO.	KEY NO.	DESCRIPTION	PART NO.
1B	Motor base	P50-300-1B	20B	Hex thin nut M8	P50-300-20B
2B	Spindle bushing with plastic insert	P50-300-2B	21B	Key 5x5x50	P50-300-21B
3B	Guide column	P50-300-3B	22B	E-clip 6mm	P50-300-22B
4B	Worm wheel frame	P50-300-4B	23B	Connecting rod axle	P50-300-23B
5B	Worm wheel spindle	P50-300-5B	24B	Countersunk screw M4x6	P50-300-24B
6B	Bearing gland	P50-300-6B	25B	Pan head screw M5x8	P50-300-25B
7B	Crank axle	P50-300-7B	26B	Hex bolt M8x20	P50-300-26B
8B	Crank	P50-300-8B	27B	Hex bolt M6x16	P50-300-27B
9B	Worm wheel	P50-300-9B	28B	Washer 8	P50-300-28B
10B	Connection rod	P50-300-10B	29B	Spring washer 8	P50-300-29B
11B	Bearing 6001-2RS	P50-300-11B	30B	Self-locking nut M5	P50-300-30B
12B	Worm gear	P50-300-12B	31B	E-clip 4mm	P50-300-31B
13B	Cover, worm wheel frame	P50-300-13B	32B	Bearing 61804	P50-300-32B
14B	Plastic housing for worm gear	P50-300-14B	33B	Bearing 6006	P50-300-33B
15B	Motor	P50-300-15B	34B	Inner circlip 55mm	P50-300-34B
16B	Bearing cover	P50-300-16B	35B	External circlip 30mm	P50-300-35B
17B	Key 4x4x12	P50-300-17B	36B	Socket head screw M5x6	P50-300-36B
18B	Hex set screw with flat M6x6	P50-300-18B	37B	Pan head screw M4x12	P50-300-37B
19B	Hex bolt M8x75	P50-300-19B			

NOTE: Please reference the Key Number when calling for Replacement Parts.

For Parts under Warranty, the Serial Number of your machine is required.

50-300 OSCILLATING SPINDLE SANDER

DIAGRAM B

WIRING DIAGRAM



This machine must be grounded. Replacement of the power supply cable should only be done by a qualified electrician. See page 5 for additional electrical information.

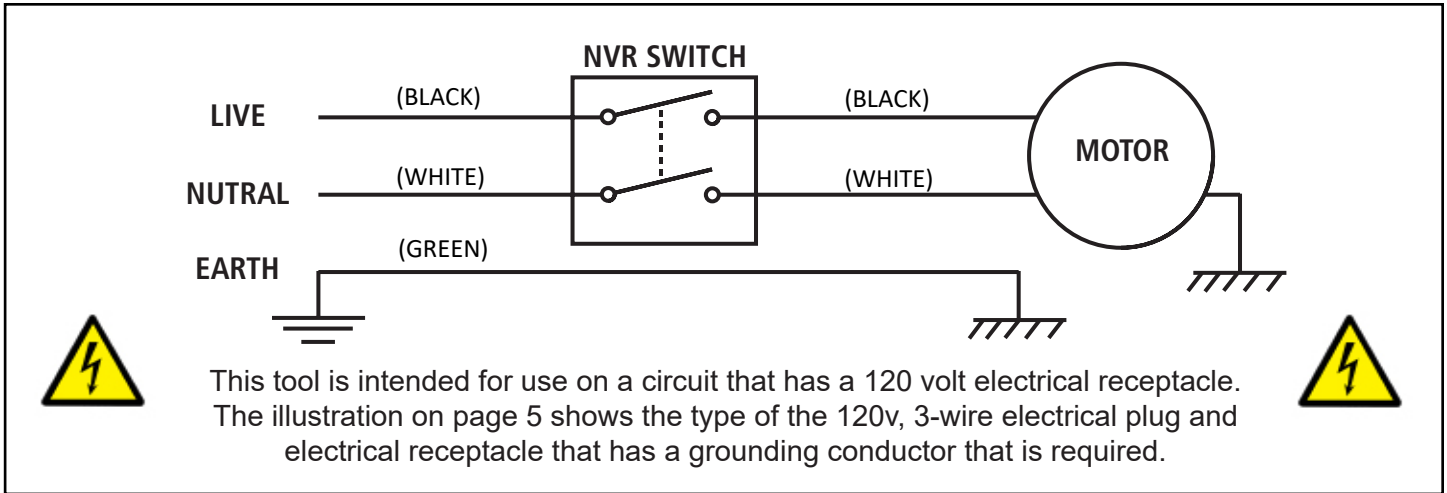

ACCESSORIES

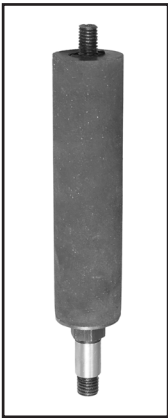

SPINDLE ASSEMBLIES

Ready to install, includes the threaded arbor, 4-1/2" rubber cylinder, top washer and nut. Fits 50-300 Spindle Sander only.

- 50-3012 1/2" Diameter**
- 50-3034 3/4" Diameter**
- 50-3001 1" Diameter**
- 50-3112 1-1/2" Diameter**
- 50-3002 2" Diameter**
- 50-3003 3" Diameter**
(3" is not included with machine)



SANDING SLEEVES

Resin bonded, Aluminum Oxide Abrasives, 4-1/2" long. Packs of 5 or 3 as listed below.

- 50-45060 60 Grit** Diameters 1/2", 3/4", 1" 1-1/2", 2" (PK 5)
- 50-45100 100 Grit** Diameters 1/2", 3/4", 1" 1-1/2", 2" (PK 5)
- 50-45150 150 Grit** Diameters 1/2", 3/4", 1" 1-1/2", 2" (PK 5)
- 50-45303 60, 100, 150 Grits** Diameter 3" (Pack of 3)

NOTES

Use this section to record maintenance, service and any calls to Technical Support:

RIKON

POWER TOOLS®

5-Year Limited Warranty

RIKON Power Tools Inc. ("Seller") warrants to only the original retail consumer/purchaser of our products that each product be free from defects in materials and workmanship for a period of five (5) years from the date the product was purchased at retail. This warranty may not be transferred.

This warranty does not apply to defects due directly or indirectly to misuse, abuse, negligence, accidents, repairs, alterations, lack of maintenance or normal wear and tear. Under no circumstances will Seller be liable for incidental or consequential damages resulting from defective products. All other warranties, expressed or implied, whether of merchantability, fitness for purpose, or otherwise are expressly disclaimed by Seller. This five-year warranty does not cover products used for commercial, industrial or educational purposes. The warranty term for these claims will be limited to a two-year period.

This limited warranty does not apply to accessory items such as blades, drill bits, sanding discs, grinding wheels, belts, guide bearings and other related items.

Seller shall in no event be liable for death, injuries to persons or property, or for incidental, contingent, special, or consequential damages arising from the use of our products.

To take advantage of this warranty, proof of purchase documentation must be provided which has the date of purchase and an explanation of the complaint.

The Seller reserves the right to effect at any time, without prior notice, those alterations to parts, fittings, and accessory equipment which they may deem necessary for any reason whatsoever.

To register your machine online, visit RIKON at www.rikontools.com/warranty

**To take advantage of this warranty, or if you have any questions,
please contact us at 877-884-5167 or email warranty@rikontools.com**



For more information:
16 Progress Road
Billerica, MA 01821

877-884-5167 / 978-528-5380
techsupport@rikontools.com



Link to RIKON Website