

## 4" x 36" Belt / 6" Disc Sander



# Operator's Manual

Record the serial number and date of purchase in your manual for future reference.

The serial number can be found on the specification label on your machine.

Serial Number: \_\_\_\_\_ Date of purchase: \_\_\_\_\_

For technical support or parts questions, email [techsupport@rikontools.com](mailto:techsupport@rikontools.com) or call toll free at (877)884-5167







## Operator Safety: Required Reading

**IMPORTANT!** Safety is the single most important consideration in the operation of this equipment. The following instructions must be followed at all times.

There are certain applications for which this tool was designed. We strongly recommend that this tool not be modified and/or used for any other application other than that for which it was designed. If you have any questions about its application, do not use the tool until you have contacted us and we have advised you.

### General Safety Warnings

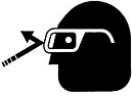
**KNOW YOUR POWER TOOL.** Read the owner's manual carefully. Learn the tool's applications, work capabilities, and its specific potential hazards.

	<b>⚠ DANGER ALWAYS GROUND ALL TOOLS.</b> If your tool is equipped with a three-pronged plug, you must plug it into a three-hole electric receptacle. If you use an adapter to accommodate a two-pronged receptacle, you must attach the adapter plug to a known ground. Never remove the third prong of the plug.  <b>ALWAYS AVOID DANGEROUS ENVIRONMENTS.</b> Never use power tools in damp or wet locations. Keep your work area well lighted and clear of clutter.
	<b>⚠ DANGER ALWAYS REMOVE THE ADJUSTING KEYS AND WRENCHES FROM TOOLS AFTER USE.</b> Form the habit of checking to see that keys and adjusting wrenches are removed from the tool before turning it on.  <b>ALWAYS KEEP YOUR WORK AREA CLEAN.</b> Cluttered areas and benches invite accidents.
	<b>⚠ DANGER ALWAYS KEEP VISITORS AWAY FROM RUNNING MACHINES.</b> All visitors should be kept a safe distance from the work area.  <b>ALWAYS MAKE THE WORKSHOP CHILDPROOF.</b> Childproof with padlocks, master switches, or by removing starter keys.
	<b>⚠ DANGER NEVER OPERATE A TOOL WHILE UNDER THE INFLUENCE OF DRUGS, MEDICATION, OR ALCOHOL.</b>
	<b>⚠ DANGER ALWAYS WEAR PROPER APPAREL.</b> Never wear loose clothing or jewelry that might get caught in moving parts. Rubber-soled footwear is recommended for the best footing.
	<b>⚠ DANGER ALWAYS USE SAFETY GLASSES AND WEAR HEARING PROTECTION.</b> Also use a face or dust mask if the cutting operation is dusty.
	<b>⚠ DANGER NEVER OVERREACH.</b> Keep your proper footing and balance at all times.
	<b>⚠ DANGER NEVER STAND ON TOOLS.</b> Serious injury could occur if the tool is tipped or if the cutting tool is accidentally

**⚠ DANGER****ALWAYS DISCONNECT TOOLS.**

Disconnect tools before servicing and when changing accessories such as blades, bits, and cutters.

**ALWAYS AVOID ACCIDENTAL STARTING.**

Make sure switch is in "OFF" position before plugging in cord.

**NEVER LEAVE TOOLS RUNNING UNATTENDED.****⚠ DANGER****ALWAYS CHECK FOR DAMAGED PARTS.**

Before initial or continual use of the tool, a guard or other part that is damaged should be checked to assure that it will operate properly and perform its intended function. Check for alignment of moving parts, binding of moving parts, breakage of parts, mounting, and any other conditions that may affect its operation. A guard or other damaged parts should immediately be properly repaired or replaced.



### Special Safety Rules For Belt & Disc Sanders

1. Do not operate this machine until you have read all of the following instructions.
2. Do not attempt to operate this machine until it is completely assembled.
3. Do not turn ON this machine if any pieces are missing.
4. If you are not familiar with the operation of the machine, obtain assistance from a qualified person.
5. It is highly recommended that this machine be firmly mounted to a flat and secure work surface or stand.
6. Always wear protective eyewear prior to operating this machine.
7. Do not operate this machine if you are under the influence of drugs and/or alcohol.
8. Remove all jewelry prior to operating this machine.
9. Do not wear any gloves while operating this machine.
10. Always make sure the power switch is in the OFF position prior to plugging in the machine.
11. Always make sure the power switch is in the OFF position when doing any assembly or setup operation.
12. Always wear a dust mask and use adequate dust collection and proper ventilation. Use of sanders can produce harmful particles while sanding certain types of woods.
13. The use of any accessories or attachments not recommended may cause injury to you and damage your machine.
14. This machine must be properly grounded.
15. Abrasive discs and belts should be the recommended width and length of the manufacturer.
16. Always keep your face and hands clear of moving parts such as belts and pulleys.
17. Keep power supply cords free of moving parts of the sander. Damaged cords can result in electric shock.
18. Maintain a 1/16" clearance between the sanding disc, sanding belt and tables
19. Always support the workpiece with the table or backstop.
20. Remove material or debris from the work area. Keep work area neat and clean.
21. Keep these instructions for future reference.

### SAVE THESE INSTRUCTIONS.

Refer to them often.

### California Proposition 65 Warning

**⚠ WARNING:** Some dust created by power sanding, sawing, grinding, drilling, and other construction activities contains chemicals known to the State of California to cause cancer and birth defects or other reproductive harm. Your risk from exposure to these chemicals varies, depending on how often you do this type of work. To reduce your exposure, work in a well-ventilated area and with approved safety equipment, such as dust masks that are specially designed to filter out microscopic particles.

For more information go to [www.P65Warnings.ca.gov/wood](http://www.P65Warnings.ca.gov/wood).

## Table of Contents

Safety Warnings.....	2-3
Sander Safety Rules .....	3
Specifications .....	4
Unpacking .....	4
Assembly .....	5
Mounting Sanding Disc and Guard.....	5
Assembling the Work Support Fence.....	6
Table Support Assembly.....	6
Mounting the Table Assembly.....	7
Operation .....	7
On/Off Switch .....	8
Leveling the Table Assembly.....	8
Installing the Sanding Belt .....	9
Electrical Requirements.....	10
Wiring Diagram.....	11
Maintenance .....	11-13
Timing Belt Replacement.....	13
Trouble Shooting.....	13
Parts List/Parts Explosion.....	14-15
Parts Explosion.....	13
Notes .....	14
Notes/Warranty .....	15-16

## Specifications

<b>Model No.</b>	<b>50-112</b>
<b>Motor</b>	
Horsepower	1/2 HP
Amps	4.3
Volts	120V, 60 Hz
<b>Belt</b>	
Size	4" x 36"
Speed	1,900 SFPM
Tilt	0° - 90°
<b>Disc</b>	
Diameter	6" PSA
Speed	3,450 RPM
<b>Table</b>	
Size	9" x 6-1/4"
Tilt	0° - 45°
Miter Gauge	Included
Miter Gauge Slot	3/8" x 5/8"
<b>Overall</b>	
Height	11"
Width	21"
Depth	10"
Base Size	15-1/4" x 6-5/8"
Net Weight	38.5 lbs
Shipping Weight	43 lbs.
Shipping Carton	22" x 11-1/2" x 12"
<b>Warranty</b>	<b>5 Years</b>

## Unpacking

When unpacking, check to make sure the following parts are included. If any parts are missing or broken, please call RIKON Power Tools at the number on the cover of this manual as soon as possible.

Item #	Description	Qty
----	Sander Body	1
35	Table	1
7	6" Sandpaper Disc	1
33	Table Support	1
6	Guard, Disc	1
60	Work Support	1
----	Miter Gauge	1
----	Plastic bag contains assembly hardware.	1

## Assembly

### Securing Sander Base Assembly to Workbench

Belt and disc sander must be fastened securely to a firm supporting surface such as a workbench.

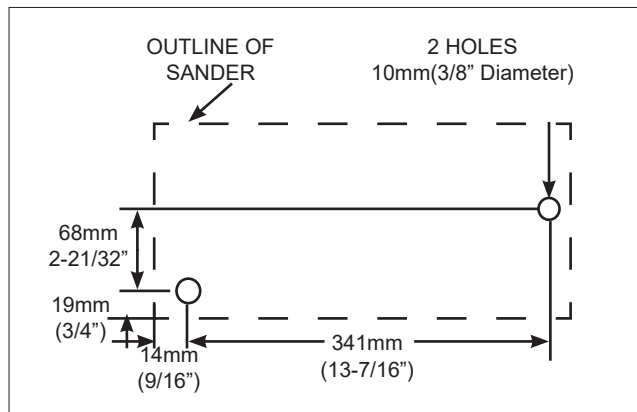

1. Place sander in operational position on workbench.
2. Place a pencil through the holes in the sander base (42) and mark drill holes in workbench.
3. Remove sander and drill two 10mm (3/8") dia. holes through the workbench.
4. Align sander base over holes and secure using two 5/16" screws and hex. nuts

### Mounting Sanding Disc and Guard

1. Locate sanding disc (7) and peel backing off disc.
2. Align perimeter of sanding disc over plate. When aligned, press sandpaper disc firmly onto backing disc.
3. Position disc guard (6) onto lower portion of sanding disc so that the mounting holes align.
4. Using a Phillips screwdriver, fasten two pan head screws (found in parts bag) over disc guard.

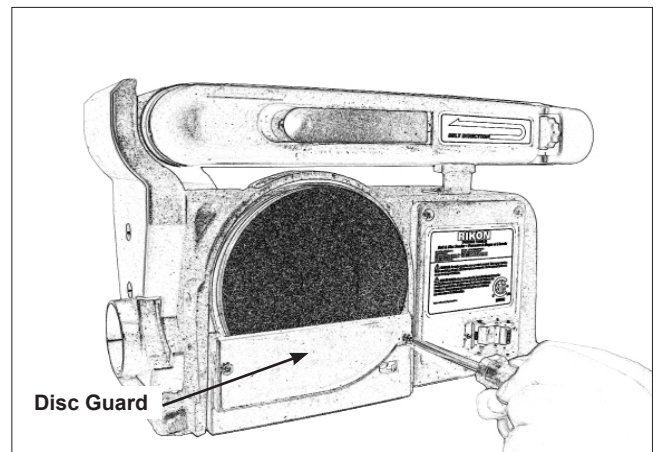
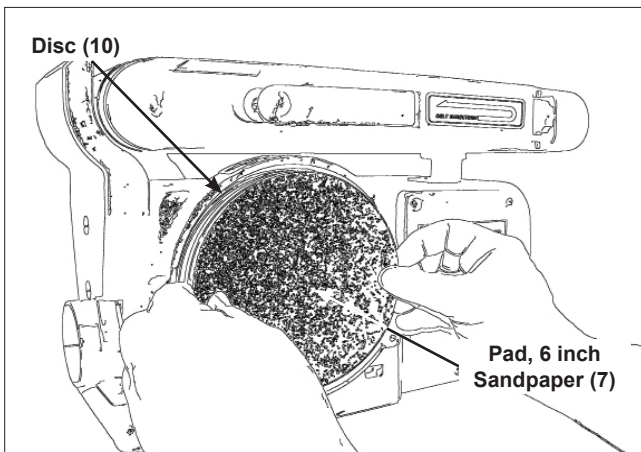

## Assembly

### Installing Work support

1. Place work support (60) over sanding belt as shown in following illustration.
2. Place the hex. screw (91) through the flat washer (90) and secure. Do not over tighten.

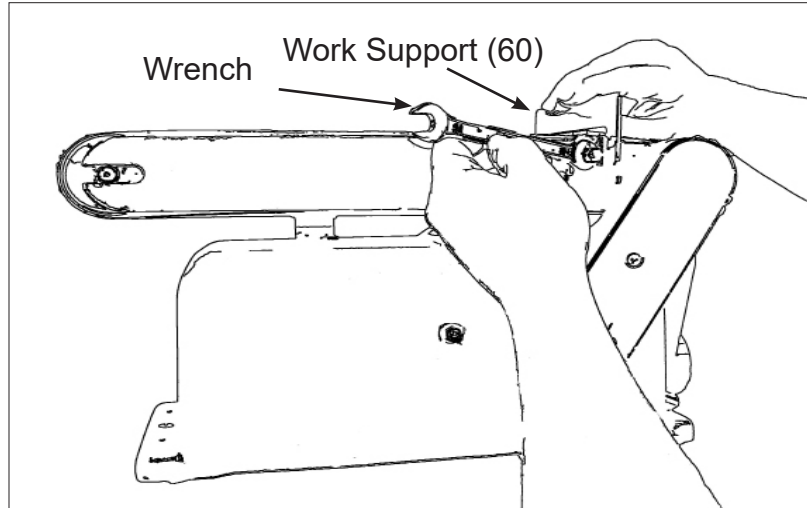

### Table Support Assembly

1. Locate the table support (33) and hex. screws (31) and washers (32).
2. Stand table (35) on its side, aligning holes as shown in below illustration.
3. Fasten table support to table. Do not over tighten screws.

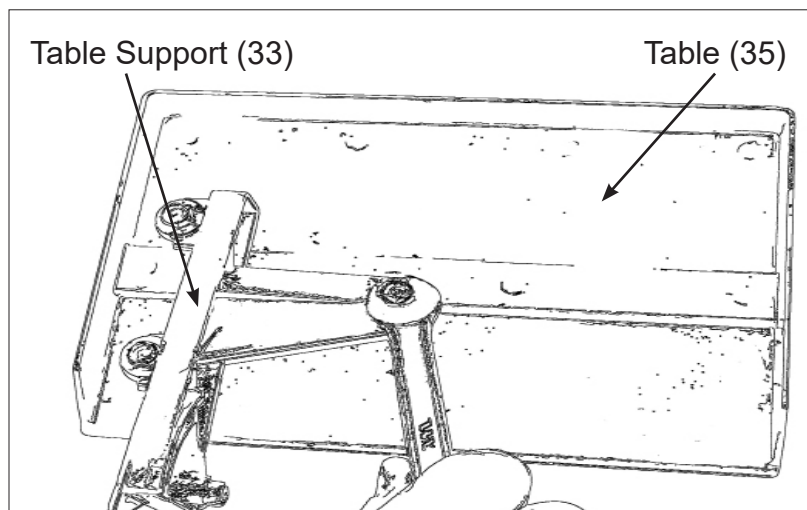



## Assembly

4. Position table support (33) in corresponding holes on side of base as shown in below illustration.

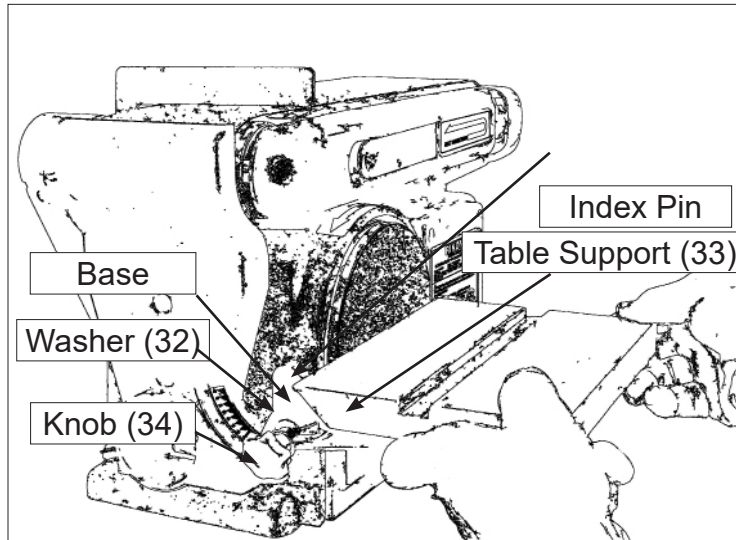

5. Place washer (32) on knob (34) shaft and insert through slot into threaded holes in base.
6. Loosen the three hex. screws (31) and adjust table so that there is a maximum of 1.5mm (1/16") space between the sanding disc and the table. Tighten screws.

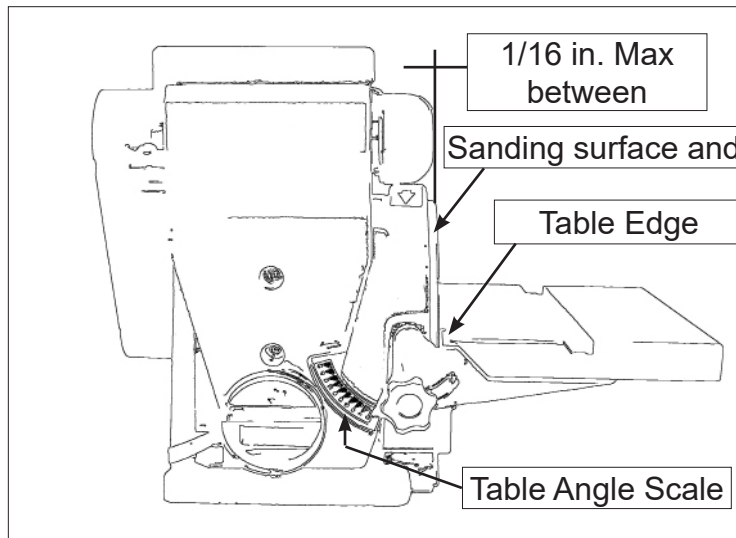

## Operation

The rocker ON/OFF power switch is located on the front of the sander, and incorporates a removable safety switch.

1. Press the side marked ON to turn the sander on.
2. Press the side marked OFF to turn the sander off.

In situations where the sander may be left unattended, the operator has the option of removing the center safety portion of the ON/OFF switch to render the sander inoperable. When the operator is ready to use the machine again, the center safety portion of the switch may be reinstalled simply by inserting it into the opening in the switch and pushing it in until it "seats".

## Operation

### Remounting Table for Vertical Sanding

1. Remove backstop lock bolt and remove work support.
2. Unscrew knob (34) and remove.
3. Pull table support (33) index pin out of mounting hole.
4. Loosen hex socket screw (75) and raise sanding bed to the desired sanding position.
5. Insert the table index pins into the auxiliary (upper) holes in the sanding bed.
6. Tighten hex socket screw (75). Make sure table is not touching sanding belt.

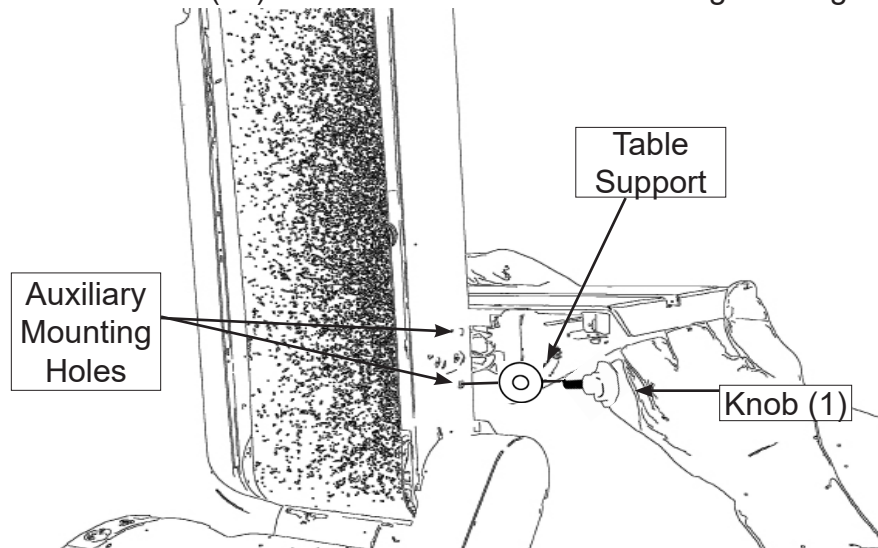

### Leveling Table Assembly

1. Place a combination square on the table (35) so that it also touches the sanding pad (7). See below. If the table is 90 degrees to the pad, the square is flush on the pad.
2. If the table is not 90 degrees to the with the pad, loosen the table lock knob (34) and tilt the table until the square is flush with the pad
3. Retighten the knob to secure the table.
4. Attach the scale label to the '0' degrees mark on the dust guard.

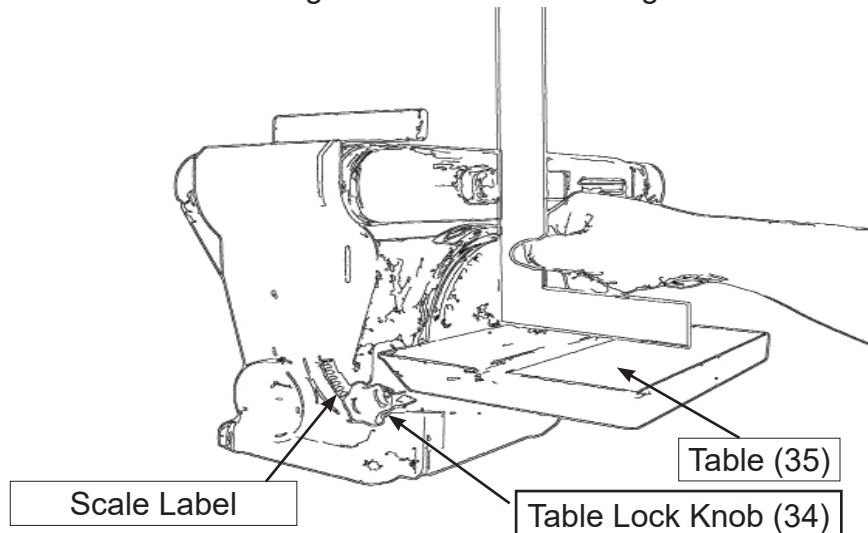



## Operation

### Installing and Adjusting the Sanding Belt

1. Turn power switch to the OFF position and disconnect power cord from the main electricity supply.
2. Move tension lever (66) to the right to release the sanding belt tension (10).
3. Place the sanding belt over the drive and idler drums (13 and 65), making sure that the inside direction arrow points down, towards the drive drum (13) as shown in illustration..
4. Centre belt on both drums.
5. Slide tension lever (66) to the left to tighten belt tension.
6. Tighten hex. socket screw (56) when bed (4) is in desired working position.

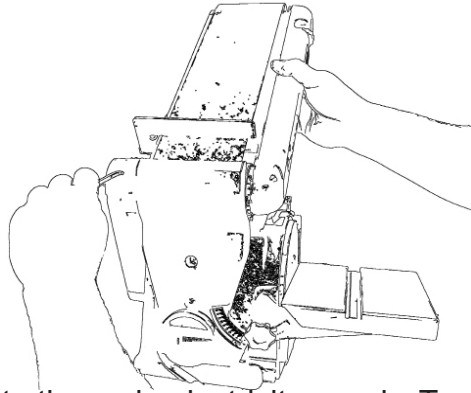

7. Reconnect the power cord to the main electricity supply. Turn the no-volt release switch (21) ON, then OFF, while viewing the belt movement. If the belt looks like it was going to slide off either drum, the belt tracking needs to be adjusted (described in the next step).
8. If the sanding belt (87) moves towards the sanding pad (7) when turned ON, turn the tracking knob (55) clockwise  $\frac{1}{4}$  turn, and test again.
9. If the sanding belt moves away from the sanding pad when it was turned ON, turn the tracking knob counterclockwise  $\frac{1}{4}$  turn, and test again.

Surface Sanding on Sanding Belt

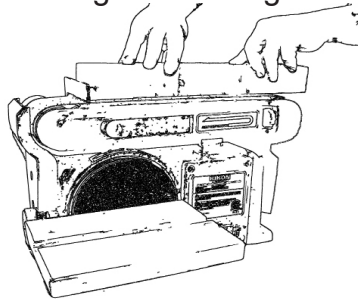

End Sanding on Sanding Belt

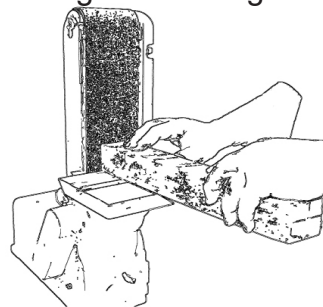

Sanding Curved Edges

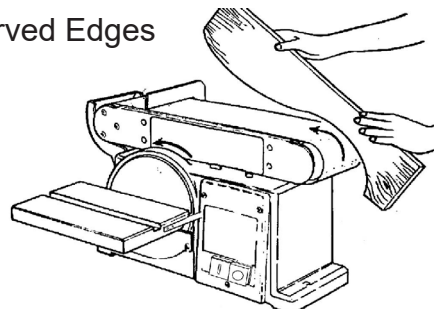
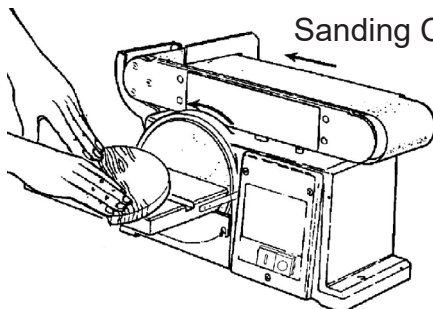

## Electrical Requirements

In the event of a malfunction or breakdown, grounding provides a path of least resistance for electric current to reduce the risk of electric shock. This tool is equipped with an electric cord having an equipment-grounding conductor and a grounding plug. The plug must be plugged into a matching outlet that is properly installed and grounded in accordance with all local codes and ordinances.

Do not modify the plug provided. If it will not fit the outlet, have the proper outlet installed by a qualified electrician.

Improper connection of the equipment-grounding conductor can result in a risk of electric shock. The conductor, with insulation having an outer surface that is green with or without yellow stripes, is the equipment-grounding conductor. If repair or replacement of the electric cord or plug is necessary, do not connect the equipment-grounding conductor to a live terminal.

Check with a qualified electrician or service personnel if the grounding instructions are not completely understood, or if in doubt as to whether the tool is properly grounded.

Use only three wire extension cords that have three-prong grounding plugs and three-pole receptacles that accept the tool's plug.\*

Repair or replace a damaged or worn cord immediately.

This tool is intended for use on a circuit that has an outlet that looks the one illustrated in Figure A below. The tool has a grounding plug that looks like the grounding plug as illustrated in Figure A below. A temporary adapter, which looks like the adapter as illustrated in Figure B below, may be used to connect this plug to a two-pole receptacle, as shown in Figure B if a properly grounded outlet is not available.\*\* The temporary adapter should only be used until a properly grounded outlet can be installed by a qualified electrician. The green colored rigid ear or tab, extending from the adapter, must be connected to a permanent ground such as a properly grounded outlet box.

\* Canadian electrical codes require extension cords to be certified SJT type or better.

\*\* Use of an adapter in Canada is not acceptable.

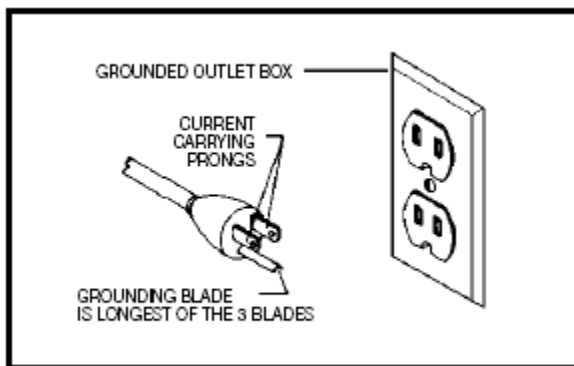

Fig. A

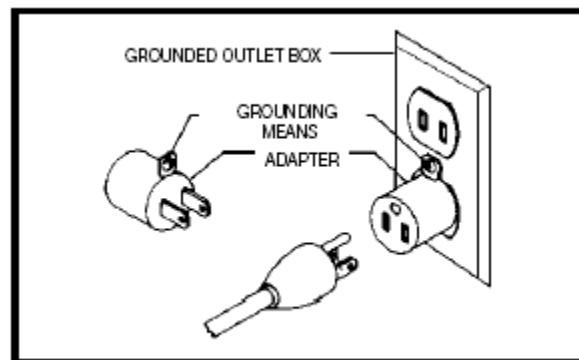

Fig. B

# Wiring Diagram

**WARNING:** This machine must be grounded.

Replacement of the power supply cable should only be done by a qualified electrician.

## 110 VOLT

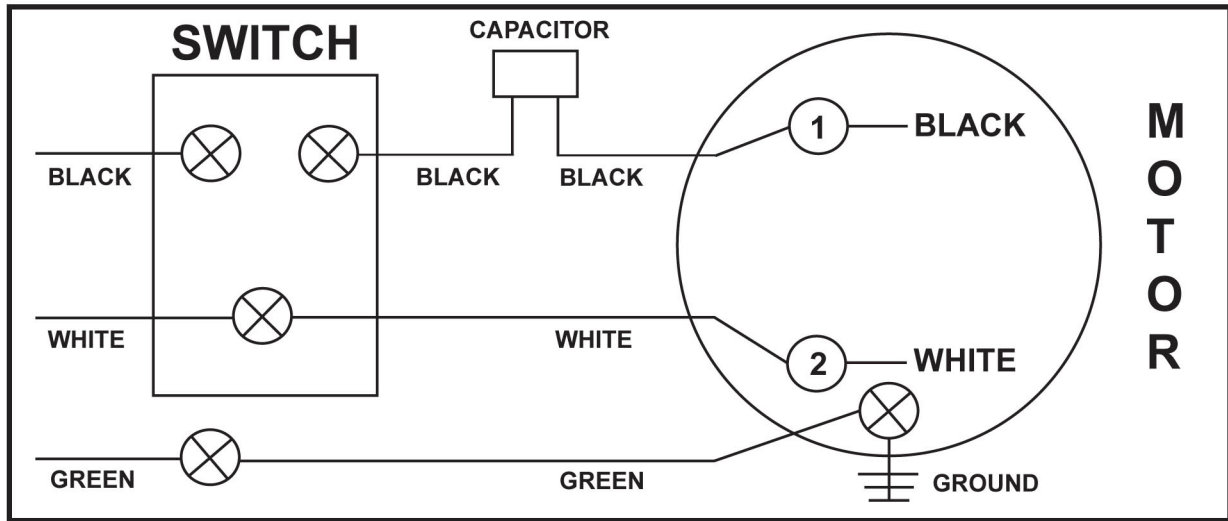

# Maintenance

Use this section to record maintenance, service and any calls to Technical Support:

---

---

---

---

---

---

---

---

---

---

---

---

---

---

---

---

---

---

---

---

---

---

---

---

## Maintenance

1. Apply a light coat of wax paste to the worktable to make feeding stock easier.
2. Use a vacuum cleaner and brush to clear out dust and debris from sander and motor.

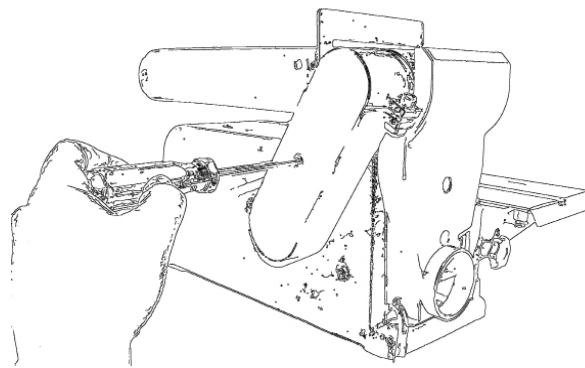

### Timing Drive Belt Replacement

1. Using a Phillips screwdriver, remove the screw (66) from belt cover (67), and remove cover.
2. Loosen three screws to allow drive pulleys (71 and 78) to move enough to place drive belt (70) around them .

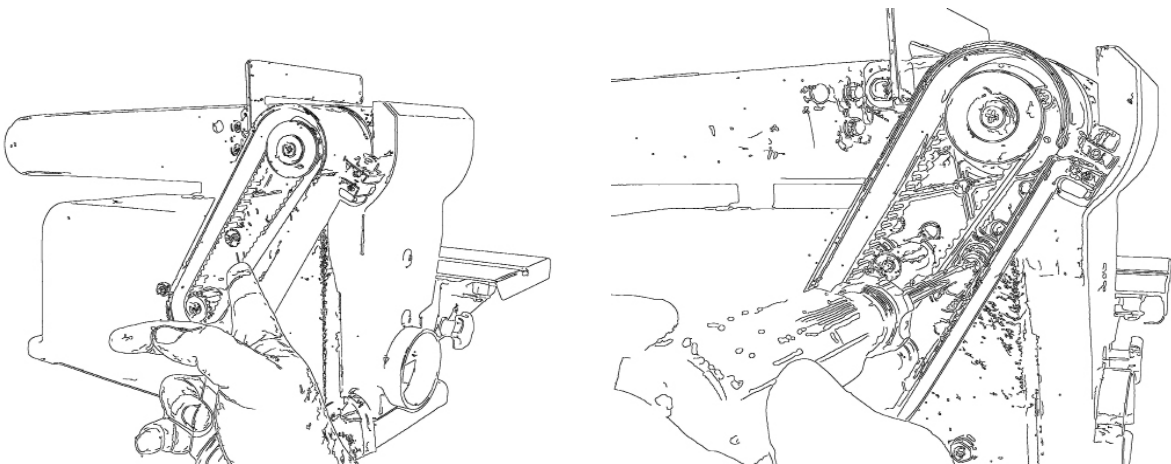

## Maintenance

3. Place drive belt around drive pulley (71), then drive pulley (78).
4. Tighten the three screws slightly.
5. Adjust tension of drive belt by placing a standard screwdriver in the adjusting hole by pushing up on the screwdriver to apply tension to the drive belt.
6. Tighten the three screws again.
7. Squeeze the drive belt between two fingers in the centre of the belt. If the belt has been correctly tensioned there should be about 6mm (1/4") of "give".  
NOTE: Too much tension on the drive belt can load-down motor and possibly cause damage. If the drive belt is too loose, it may fail prematurely.
8. Replace belt cover (67) .

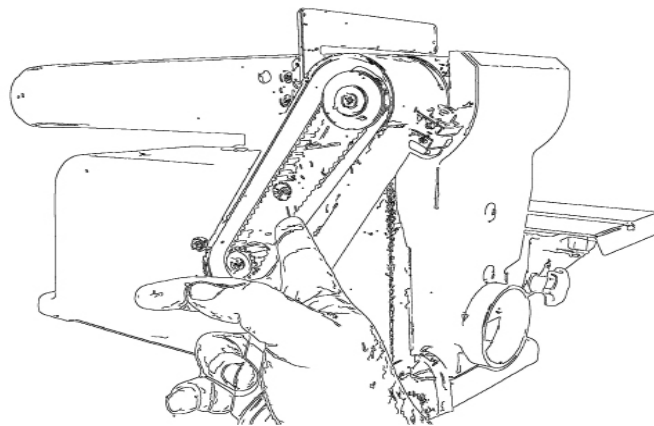

## Troubleshooting

SYMPTOM	PROBABLE CAUSE	REMEDY
Sander does not operate	Not plugged in to power outlet. Power switch defective. Motor or wiring problem.	Plug into power outlet. Replace switch. Have qualified electrician carry out repair.
Motor slows when sanding	Timing belt too tight Applying too much pressure on workpiece.	Decrease tension. Apply less pressure to workpiece when sanding.
Wood burns while sanding	Sanding disc or belt is loaded with debris.	Clean or replace disc or belt.
Sander makes excessive noise	Timing belt too tight. Bearings need oil.	Decrease tension Oil bearings.

## Parts List

<b>Part No.</b>	<b>Description</b>	<b>Part No.</b>	<b>Description</b>
50-112-1	Phillips Screw M4X6	50-112-46	Idler Shaft
50-112-2	Flat Washer D4	50-112-47	Phillips Screw M5X20
50-112-3	Base Cover	50-112-49	Screw Bushing
50-112-4	Phillips Screw ST4.2X10	50-112-50	Draw Extend Spring
50-112-5	Toothed Lock Washer D4	50-112-51	Belt Tension Knob
50-112-6	Disc Cover	50-112-52	Big Flat Washer D5
50-112-7	Disc Paper 80#	50-112-53	Hex Nut, Type I M6
50-112-8	Hex Socet Round Head Screw M6X16	50-112-54	Phillips Screw M5X16
50-112-9	Toothed Lock Washer D6	50-112-55	Adjust Knob
50-112-10	Disc	50-112-56	Flat Washer D6
50-112-11	Wheel Box	50-112-57	Rubber Washer
50-112-12	Phillips Screw M5X8	50-112-58	Adjust Spring
50-112-13	Spring Washer D5	50-112-59	Belt Support
50-112-14	Flat Washer D5	50-112-60	Work Rest
50-112-15	Toothed Lock Washer D5	50-112-61	Driving Pulley
50-112-17	Base	50-112-62	Hex Flat Lock Washer M8X12
50-112-18	Phillips Screw ST4.2X20	50-112-63	Driving Pulley
50-112-19	Wire Connection Box Cover	50-112-64	Bearing Cap
50-112-20	Phillips Screw ST2.9X28	50-112-65	Support Cover
50-112-21	Relay	50-112-66	Phillips Screw M5X10
50-112-22	Wire Connection Box	50-112-67	Cog Belt Guard Cover
50-112-23	Phillips Screw M5X10	50-112-68	Phillips Screw M5X16I
50-112-24	Electromagnetism Power Switch	50-112-69	Special Locked Washer
50-112-25	Phillips Screw M6X8	50-112-70	Cog Belt
50-112-26	Spring Washer D6	50-112-71	Driven Pulley
50-112-27	Hex Nut, Type I M5	50-112-72	Phillips Screw M5X25
50-112-28	Capacitor	50-112-73	Bearing Base
50-112-29	Capacitor Support	50-112-74	Phillips Screw M6X25
50-112-30	Phillips Screw M5X12	50-112-75	Hex Socket Round Head Screw M8X25
50-112-31	Hex Bolt M6X12	50-112-76	Cog Belt Guard Cover
50-112-32	Big Flat Washer D6	50-112-77	Square Nut
50-112-33	Work Table Support Angle Plate	50-112-78	Driving Pulley
50-112-34	Miter Gauge Knob	50-112-79	Phillips Screw M4X6
50-112-35	Work Table	50-112-81	Motor Assy
50-112-36	Miter Gauge Bar	50-112-82	Cord & Plug
50-112-37	Point of Miter Gauge	50-112-83	Dust Collect
50-112-38	Miter Gauge of Work Table	50-112-85	Support Cushion
50-112-39	Pulley Guard Plate	50-112-86	Belt Frame Support
50-112-40	Tension Spring	50-112-87	Belt #80
50-112-41	Bushing	50-112-88	Switch Protect Cover
50-112-42	Belt Tension Support	50-112-89	Phillips Screw
50-112-43	Spring Retaining Ring for Shaft D12	50-112-90	Flat Washer D8
50-112-44	Bearing 101Z	50-112-91	Hex Socket Round Head Screw M8X16
50-112-45	Idler Drum		



# Parts Explosion

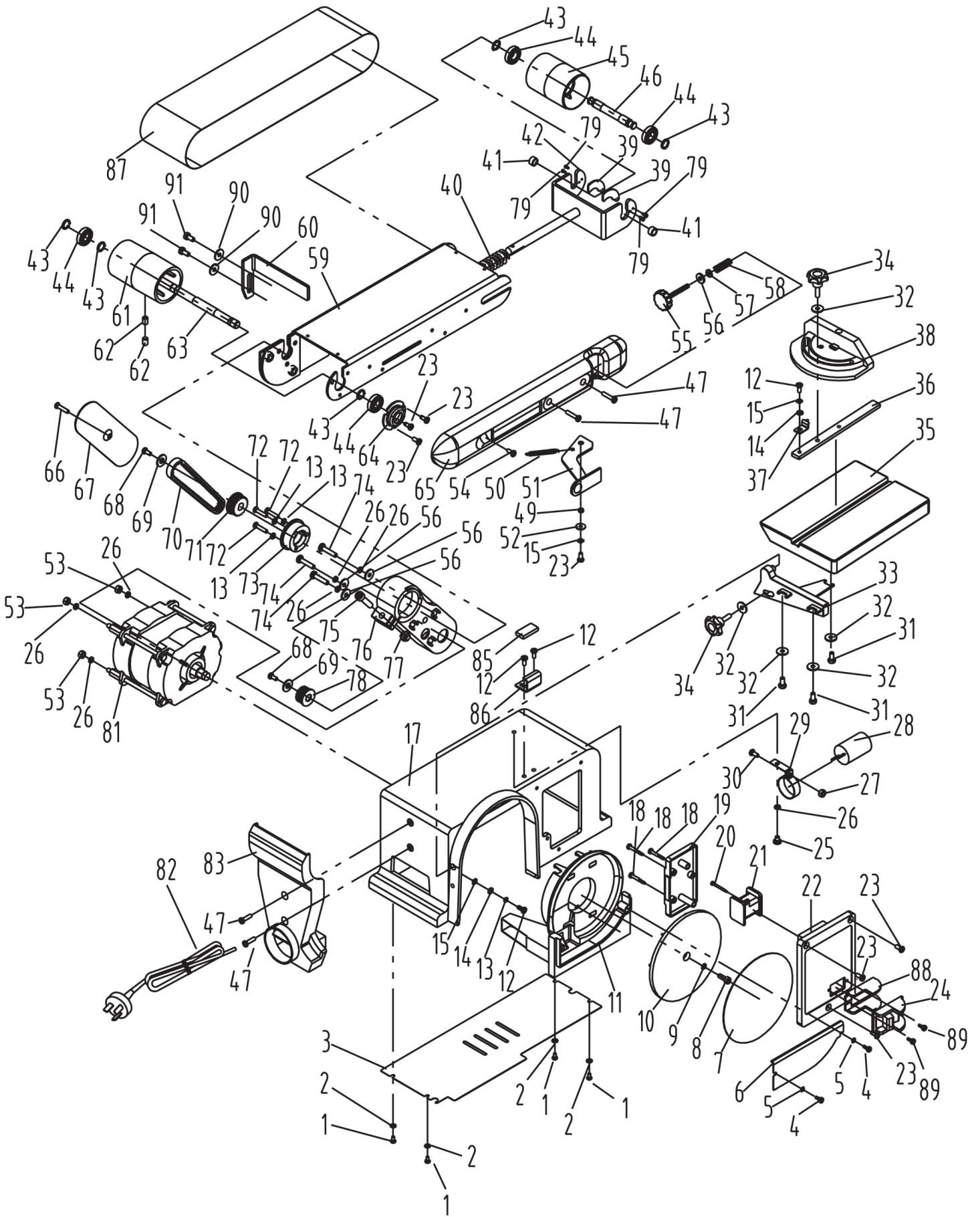



# **RIKON**

## **POWER TOOLS®**

### **5-Year Limited Warranty**

RIKON Power Tools Inc. ("Seller") warrants to only the original retail consumer/purchaser of our products that each product be free from defects in materials and workmanship for a period of five (5) years from the date the product was purchased at retail. This warranty may not be transferred.

This warranty does not apply to defects due directly or indirectly to misuse, abuse, negligence, accidents, repairs, alterations, lack of maintenance or normal wear and tear. Under no circumstances will Seller be liable for incidental or consequential damages resulting from defective products. All other warranties, expressed or implied, whether of merchantability, fitness for purpose, or otherwise are expressly disclaimed by Seller. This five-year warranty does not cover products used for commercial, industrial or educational purposes. The warranty term for these claims will be limited to a two-year period.

This limited warranty does not apply to accessory items such as blades, drill bits, sanding discs, grinding wheels, belts, guide bearings and other related items.

Seller shall in no event be liable for death, injuries to persons or property, or for incidental, contingent, special, or consequential damages arising from the use of our products.

To take advantage of this warranty, proof of purchase documentation must be provided which has the date of purchase and an explanation of the complaint.

The Seller reserves the right to effect at any time, without prior notice, those alterations to parts, fittings, and accessory equipment which they may deem necessary for any reason whatsoever.

**To register your machine online, visit RIKON at [www.rikontools.com/warranty](http://www.rikontools.com/warranty)**

**To take advantage of this warranty, or if you have any questions,  
please contact us at 877-884-5167 or email [warranty@rikontools.com](mailto:warranty@rikontools.com)**



**For more information:  
16 Progress Road  
Billerica, MA 01821**

**877-884-5167 / 978-528-5380  
techsupport@rikontools.com**