

18" Wood/Metal Bandsaw



Operator's Manual

Record the serial number and date of purchase in your manual for future reference.
The serial number can be found on the specification label on the rear of your machine.

Serial Number: _____ Date of purchase: _____

TABLE OF CONTENTS

Specifications.....	2
Safety Instructions	3 - 6
Getting To Know Your Machine	7
Contents of Package	8 - 9
Installation	9
Assembly	10 - 12
Adjustments.....	12 - 20
Operation	21 - 23
Wiring Diagram	23
Maintenance	23 - 24
Notes	24
Troubleshooting	25 - 27
Parts Diagrams & Parts Lists	28 - 37
Accessories	38
Warranty	39

SPECIFICATIONS

Motor	2.5 HP, TEFC
Motor Speed (no load).....	1,400 RPM
Volts	230 V
Amps, Hertz	12.5 A, 60 Hz
Blade Length	153" (3,886 mm)
Blade Width	1/4" - 1-3/8" (6.35 - 35 mm)
Blade Speeds (Low Range).....	82 - 1,800 ft/min (25 -549 m/min)
Blade Speeds (High Range).....	140 - 3,280 ft/min (43 -1,000 m/min)
Table Size (W x D)	21-1/2" x 15-3/4" (546 x 400 mm)
Table Side Extension Size (W x D).....	4-3/8" x 15-3/4" (110 x 400 mm)
Table Tilt	Left -10° , Right 45°
Maximum Cutting Width (throat)	17-1/2" (445 mm)
Maximum Cutting Depth (height)	13" (330 mm)
Table Height	35-1/2" (902 mm)
Fence Height	6" (152 mm)
Fence Length	18-3/4" (475 mm)
Miter Gauge T-Slots (2)	3/4" x 3/8" (19.05 x 9.5 mm)
Dust Ports (2)	4" Diameter (100 mm)
Base Size	29-11/32" x 18-1/8" x 2-7/16" (745 x 460 x 62.5 mm)
Overall Height	72-7/8" (1850 mm)
Overall Size (WxDxH)	38-1/2"x29-1/8"x72-7/8" (976x740x1850 mm)
Net Weight	403.5 lbs (183 kg)

NOTE: The specifications, photographs, drawings and information in this manual represent the current model when the manual was prepared. Changes and improvements may be made at any time, with no obligation on the part of Rikon Power Tools, Inc. to modify previously delivered units. Reasonable care has been taken to ensure that the information in this manual is correct, to provide you with the guidelines for the proper safety, assembly and operation of this machine.

SAFETY INSTRUCTIONS

IMPORTANT! Safety is the single most important consideration in the operation of this equipment. **The following instructions must be followed at all times.** Failure to follow all instructions listed below may result in electric shock, fire, and/or serious personal injury.

There are certain applications for which this tool was designed. We strongly recommend that this tool not be modified and/or used for any other application other than that for which it was designed. If you have any questions about its application, do not use the tool until you have contacted us and we have advised you.

SAFETY SYMBOLS



SAFETY ALERT SYMBOL: Indicates DANGER, WARNING, or CAUTION. This symbol may be used in conjunction with other symbols or pictographs.



Indicates an imminently hazardous situation, which, if not avoided, could result in death or serious injury.



Indicates a potentially hazardous situation, which, if not avoided, could result in death or serious injury.



Indicates a potentially hazardous situation, which, if not avoided, could result in minor or moderate injury.

NOTICE: Shown without Safety Alert Symbol indicates a situation that may result in property damage.

GENERAL SAFETY

KNOW YOUR POWER TOOL. Read the owner's manual carefully. Learn the tool's applications, work capabilities, and its specific potential hazards.

BEFORE USING YOUR MACHINE

To avoid serious injury and damage to the tool, read and follow all of the Safety and Operating Instructions before operating the machine.

1.  Some dust created by using power tools contains chemicals known to the State of California to cause cancer, birth defects, or other reproductive harm. Some examples of these chemicals are:

- Lead from lead-based paints.
- Crystalline silica from bricks, cement, and other masonry products.
- Arsenic and chromium from chemically treated lumber.

Your risk from these exposures varies, depending on how often you do this type of work. To reduce your exposure to these chemicals: work in a well ventilated area and work with approved safety equipment, such as those dust masks that are specially designed to filter out microscopic particles.

2. **READ** the entire Owner's Manual. **LEARN** how to use the tool for its intended applications.

3. **GROUND ALL TOOLS.** If the tool is supplied with a 3 prong plug, it must be plugged into a 3-contact electrical receptacle. The 3rd prong is used to ground the tool and provide protection against accidental electric shock. **DO NOT** remove the 3rd prong. See Grounding Instructions on the following pages.

4. **AVOID A DANGEROUS WORKING ENVIRONMENT.** **DO NOT** use electrical tools in a damp environment or expose them to rain.

5. **DO NOT** use electrical tools in the presence of flammable liquids or gasses.

6. **ALWAYS** keep the work area clean, well lit, and organized. **DO NOT** work in an environment with floor surfaces that are slippery from debris, grease, and wax.

7. **KEEP VISITORS AND CHILDREN AWAY. DO NOT** permit people to be in the immediate work area, especially when the electrical tool is operating.

8. **DO NOT FORCE THE TOOL** to perform an operation for which it was not designed. It will do a safer and higher quality job by only performing operations for which the tool was intended.

9. **WEAR PROPER CLOTHING. DO NOT** wear loose clothing, gloves, neckties, or jewelry. These items can get caught in the machine during operations and pull the operator into the moving parts. The user must wear a protective cover on their hair, if the hair is long, to prevent it from contacting any moving parts.

10. **CHILDPROOF THE WORKSHOP AREA** by removing switch keys, unplugging tools from the electrical receptacles, and using padlocks.

11. **ALWAYS UNPLUG THE TOOL FROM THE ELECTRICAL RECEPTACLE** when making adjustments, changing parts or performing any maintenance.

SAFETY INSTRUCTIONS

12. KEEP PROTECTIVE GUARDS IN PLACE AND IN WORKING ORDER.

13. **AVOID ACCIDENTAL STARTING.** Make sure that the power switch is in the “OFF” position before plugging in the power cord to the electrical receptacle.

14. **REMOVE ALL MAINTENANCE TOOLS** from the immediate area prior to turning “ON” the machine.

15. **USE ONLY RECOMMENDED ACCESSORIES.** Use of incorrect or improper accessories could cause serious injury to the operator and cause damage to the tool. If in doubt, check the instruction manual that comes with that particular accessory.

16. **NEVER LEAVE A RUNNING TOOL UNATTENDED.** Turn the power switch to the “OFF” position. **DO NOT** leave the tool until it has come to a complete stop.

17. **DO NOT STAND ON A TOOL.** Serious injury could result if the tool tips over, or you accidentally contact the tool.

18. **DO NOT** store anything above or near the tool where anyone might try to stand on the tool to reach it.

19. **MAINTAIN YOUR BALANCE. DO NOT** extend yourself over the tool. Wear oil resistant rubber soled shoes. Keep floor clear of debris, grease, and wax.

20. **MAINTAIN TOOLS WITH CARE.** Always keep tools clean and in good working order. Keep all blades and tool bits sharp, dress grinding wheels and change other abrasive accessories when worn.

21. **EACH AND EVERY TIME, CHECK FOR DAMAGED PARTS PRIOR TO USING THE TOOL.** Carefully check all guards to see that they operate properly, are not damaged, and perform their intended functions. Check for alignment, binding or breaking of moving parts. A guard or other part that is damaged should be immediately repaired or replaced.

22. **DO NOT OPERATE TOOL WHILE TIRED, OR UNDER THE INFLUENCE OF DRUGS, MEDICATION OR ALCOHOL.**

23. **SECURE ALL WORK.** Use clamps or jigs to secure the workpiece. This is safer than attempting to hold the workpiece with your hands.

24. **STAY ALERT, WATCH WHAT YOU ARE DOING, AND USE COMMON SENSE WHEN OPERATING A POWER TOOL.**

A moment of inattention while operating power tools may result in serious personal injury.

25. **ALWAYS WEAR A DUST MASK TO PREVENT INHALING DANGEROUS DUST OR AIRBORNE PARTICLES,** including wood dust, crystalline silica dust and asbestos dust. Direct particles away from face and body. Always operate tool in well ventilated area and provide for proper dust removal. Use dust collection system wherever possible. Exposure to the dust may cause serious and permanent respiratory or other injury, including silicosis (a serious lung disease), cancer, and death. Avoid breathing the dust, and avoid prolonged contact with dust. Allowing dust to get into your mouth or eyes, or lay on your skin may promote absorption of harmful material. Always use properly fitting NIOSH/OSHA approved respiratory protection appropriate for the dust exposure, and wash exposed areas with soap and water.

26. **USE A PROPER EXTENSION CORD IN GOOD CONDITION.** When using an extension cord, be sure to use one heavy enough to carry the current your product will draw. The table on the following page shows the correct size to use depending on cord length and nameplate amperage rating. If in doubt, use the next heavier gauge. The smaller the gauge number, the larger diameter of the extension cord. If in doubt of the proper size of an extension cord, use a shorter and thicker cord. An undersized cord will cause a drop in line voltage resulting in a loss of power and overheating.
USE ONLY A 3-WIRE EXTENSION CORD THAT HAS A 3-PRONG GROUNDING PLUG AND A 3-POLE RECEPTACLE THAT ACCEPTS THE TOOL’S PLUG.

27. **ADDITIONAL INFORMATION** regarding the safe and proper operation of this product is available from:

- Power Tool Institute
1300 Summer Avenue
Cleveland, OH 44115-2851
www.powertoolinstitute.org
- National Safety Council
1121 Spring Lake Drive
Itasca, IL 60143-3201
www.nsc.org
- American National Standards Institute
25 West 43rd Street, 4th Floor
New York, NY 10036
www.ansi.org
- ANSI 01.1 Safety Requirements for Woodworking Machines and the U.S. Department of Labor regulations
www.osha.gov

28. **SAVE THESE INSTRUCTIONS.** Refer to them frequently and use them to instruct others.

SAFETY INSTRUCTIONS

ELECTRICAL SAFETY

⚠ WARNING: THIS TOOL REQUIRES THE INSTALLATION OF A 220V PLUG (NOT INCLUDED), AND MUST BE GROUNDED WHILE IN USE TO PROTECT THE OPERATOR FROM ELECTRIC SHOCK.

IN THE EVENT OF A MALFUNCTION OR BREAKDOWN, grounding provides the path of least resistance for electric current and reduces the risk of electric shock. This tool is equipped with an electric cord that has an equipment grounding conductor and requires a grounding plug (not included). The plug **MUST** be plugged into a matching electrical receptacle that is properly installed and grounded in accordance with **ALL** local codes and ordinances.

DO NOT MODIFY ANY PLUG. If it will not fit the electrical receptacle, have the proper electrical receptacle installed by a qualified electrician.

IMPROPER ELECTRICAL CONNECTION of the equipment grounding conductor can result in risk of electric shock. The conductor with the green insulation (with or without yellow stripes) is the equipment grounding conductor. **DO NOT** connect the equipment grounding conductor to a live terminal if repair or replacement of the electric cord or plug is necessary.

CHECK with a qualified electrician or service personnel if you do not completely understand the grounding instructions, or if you are not sure the tool is properly grounded when installing or replacing a plug.

REPLACE A DAMAGED OR WORN CORD IMMEDIATELY.

This tool is intended for use on a circuit that has a 220 volt electrical receptacle. **FIGURE 1** shows the type of the 220V, 4-wire electrical plug and electrical receptacle that has a grounding conductor that is required.

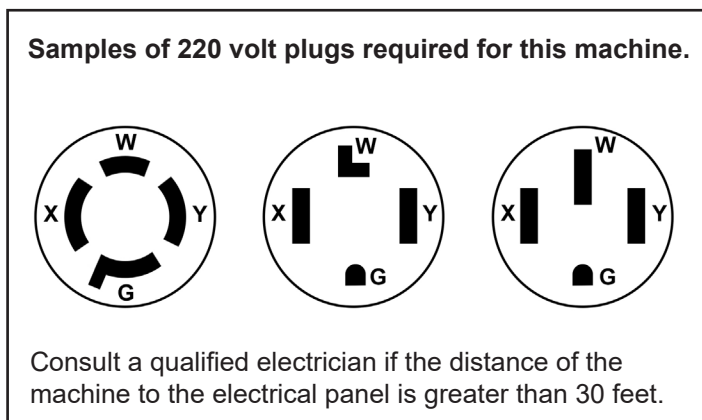

Figure 1

EXTENSION CORDS

⚠ WARNING: USE OF AN EXTENSION CORD WITH THIS MACHINE IS NOT RECOMMENDED. FOR BEST POWER AND SAFETY, PLUG THE MACHINE DIRECTLY INTO A DEDICATED GROUNDED ELECTRICAL OUTLET THAT IS WITHIN THE SUPPLIED CORD LENGTH OF THE MACHINE.

IF AN EXTENSION CORD NEEDS TO BE USED, IT SHOULD ONLY BE FOR LIMITED OPERATION OF THE MACHINE. THE EXTENSION CORD SHOULD BE AS SHORT AS POSSIBLE IN LENGTH, AND HAVE A MINIMUM GAUGE SIZE OF 14AWG.

USE ONLY A 4-WIRE EXTENSION CORD THAT HAS THE PROPER TYPE OF A 4-PRONG GROUNDING PLUG THAT MATCHES THE MACHINE'S 4-PRONG PLUG AND ALSO THE 4-POLE RECEPTACLE THAT ACCEPTS THE TOOL'S PLUG. *

⚠ WARNING: Check extension cords before each use. If damaged replace immediately. Never use a tool with a damaged cord, since touching the damaged area could cause electrical shock, resulting in serious injury.

Use a proper extension cord. Only use cords listed by Underwriters Laboratories (UL). Other extension cords can cause a drop in line voltage, resulting in a loss of power and overheating of tool. When operating a power tool outdoors, use an outdoor extension cord marked "W-A" or "W". These cords are rated for outdoor use and reduce the risk of electric shock.

⚠ WARNING: Keep the extension cord clear of the working area. Position the cord so that it will not get caught on lumber, tools or other obstructions while you are working with a power tool.

* Canadian electrical codes require extension cords to be certified SJT type or better.

** The use of an adapter in Canada is not acceptable.



THIS SYMBOL DESIGNATES THAT THIS TOOL IS LISTED BY THE INTERTEK TESTING SERVICES, TO UNITED STATES AND CANADIAN STANDARDS.

SAFETY INSTRUCTIONS

SPECIFIC SAFETY INSTRUCTIONS FOR BAND SAWS

This machine is intended for the cutting of natural, solid woods, composite materials, plastics and non-ferrus metals. The permissible workpiece dimensions must be observed (see Technical Specification). Any other use not as specified, including modification of the machine or use of parts not tested and approved by the equipment manufacturer, can cause unforeseen damage and invalidate the warranty.

ATTENTION: Use of this band saw still presents risks that cannot be eliminated by the manufacturer. Therefore, the user must be aware that wood working machines are dangerous if not used with care and all safety precautions are adhered to.

1. Do not operate this machine until you have read all of the following instructions.
2. If you are not familiar with the operation of the machine, obtain assistance from a qualified person.
3. Always wear approved, safety protective eye wear and hearing protection when operating this machine.
4. Always wear a dust mask and use adequate dust collection and proper ventilation.
5. Adjust the upper guides about 1/8" to 1/4" above the material being cut.
6. Check for proper blade size and type for the thickness and type of material being cut.
7. Make sure that the blade tension and blade tracking are properly adjusted.
8. Always keep hands and fingers away from the blade.
9. Make "relief" cuts before cutting curves to eliminate blade binding.
10. Always hold material firmly, resting flat on the table and feed it into the blade at a moderate speed.
11. Never attempt to saw stock that does not have a flat surface, unless a suitable support is used.
12. When cutting small work pieces, always use a push stick, holding jig or other device to keep your hands safely away from the blade. Use 'Zero Clearance Inserts' to prevent small pieces from becoming jammed in the table insert or lower blade guides.
13. Always allow the bandsaw blade to stop before removing scrap pieces from the table.
14. Do not remove jammed pieces from the saw until the machine and blade has stopped. Unplug the bandsaw from the power source, and then remove the jammed work piece.
15. Always turn off the machine if the material is to be backed out of an uncompleted cut.
16. Use extra supports (roller stands, saw horses, tables etc.) for any work pieces large enough to tip when not held down to the table top surface.
17. Always turn off and unplug the machine when changing blades or servicing the machine.
18. Release blade tension when the saw will not be used for a long period of time.
19. Remove material or debris from the work area. Keep work area neat and clean.

SAVE THESE INSTRUCTIONS.

Refer to them often.

CALIFORNIA PROPOSITION 65 WARNING:

 **WARNING:** Drilling, sawing, sanding or machining wood products can expose you to wood dust, a substance known to the State of California to cause cancer. Avoid inhaling wood dust or use a dust mask or other safeguards for personal protection. For more information go to www.P65Warnings.ca.gov/wood.

This owner's manual is not a teaching aid. Use of this owner's manual is intended to show assembly, adjustments, and general use.

GETTING TO KNOW YOUR MACHINE

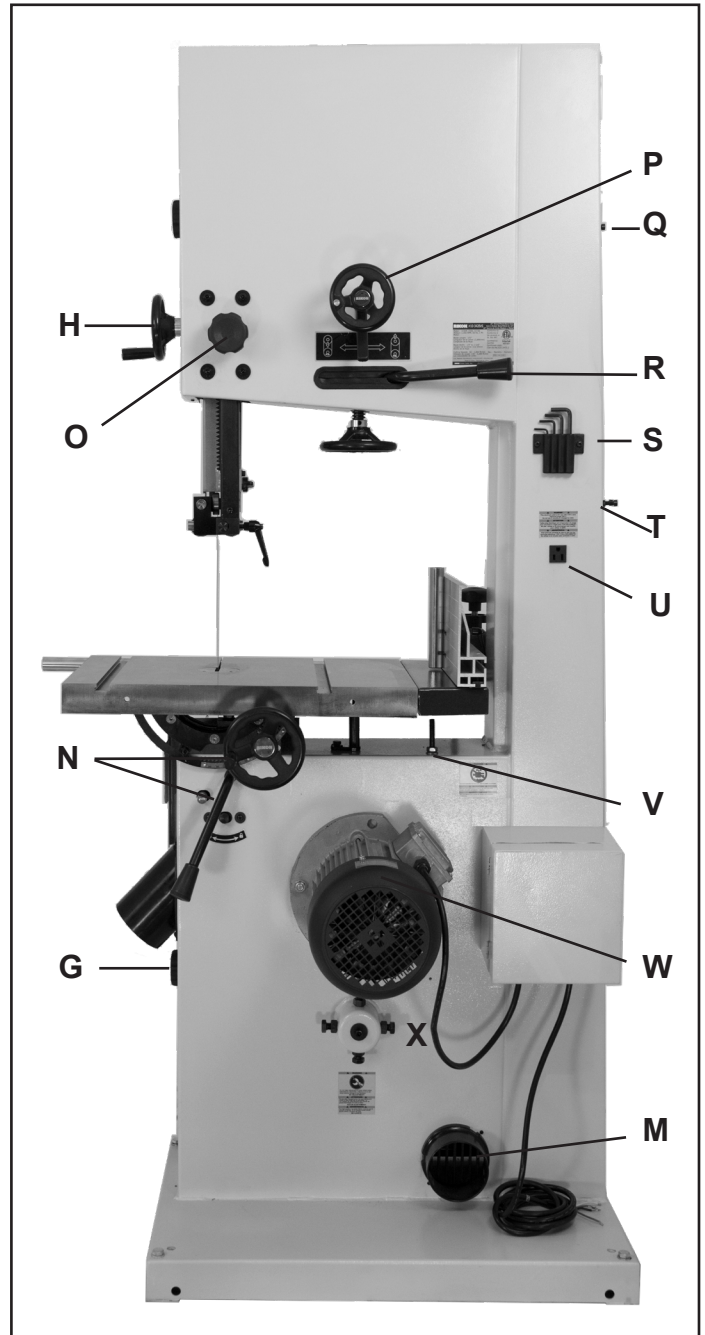
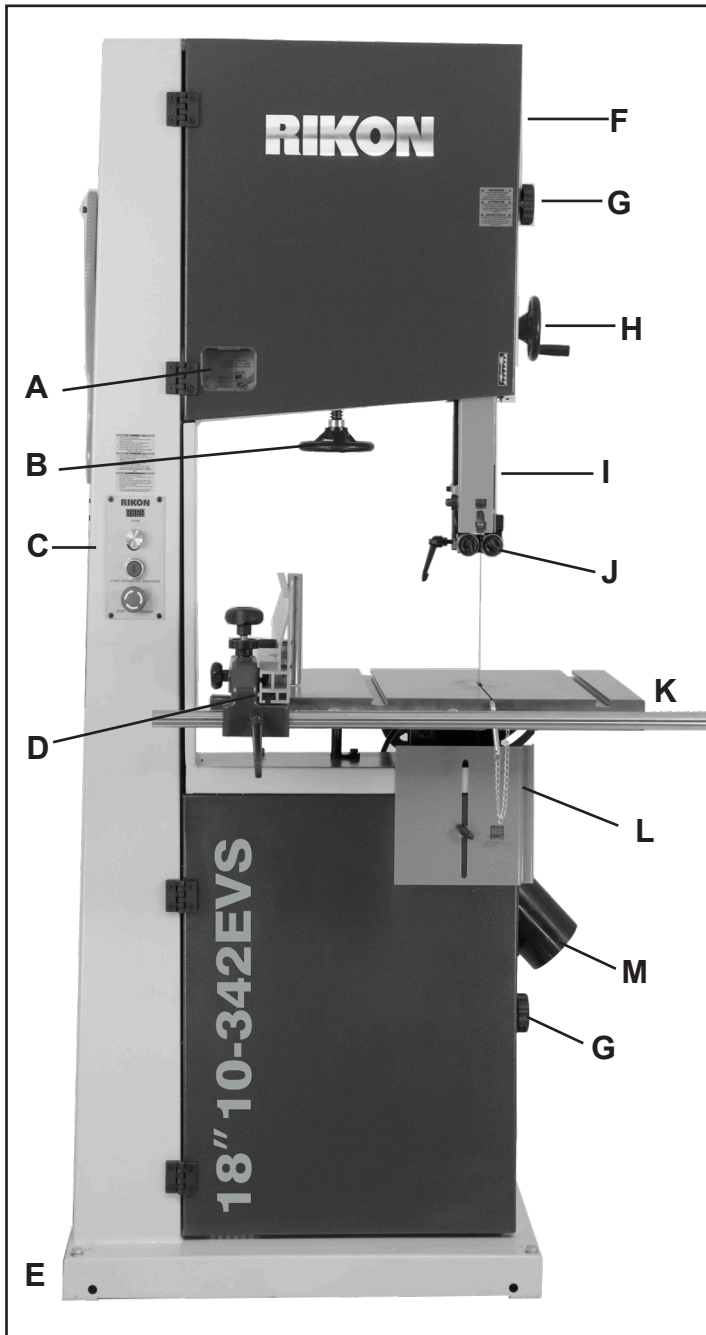

- A. Tension Indicator Window
- B. Blade Tension Hand Wheel
- C. Control Panel
- D. Rip Fence, Rail & Re-saw Bar
- E. Base
- F. Blade Tracking Window
- G. Door Lock Knob
- H. Guide Post Rise/Fall Handle
- I. Blade Guard
- J. Upper Blade Guides
- K. Work Table
- L. Lower Blade Guides & Blade Guard

- M. 4" Dust Port
- N. Table Tilt Wheel & Locking Handle
- O. Guide Post Lock Knob
- P. Blade Tracking Knob
- Q. Push Stick & Hanger Bolt
- R. Blade Tension Quick Release Lever
- S. Tool Holder
- T. Hanger Bolts for Tow Bar (optional)
- U. Electrical Outlet 110V
- V. Motor Adjusting Rod & Nut
- W. Motor & Wiring Box
- X. Lower Wheel Adjustment Bolts

CONTENTS OF PACKAGE

Model 10-342EVS 18" Wood/Metal Bandsaw is shipped complete in one box.

Unpacking, Checking Contents & Clean-up

1. Carefully remove all contents from the shipping carton. Compare the contents with the list of contents to make sure that all of the items are accounted for, before discarding any packing material. Place parts on a protected surface for easy identification and assembly. If any parts are missing or broken, please call RIKON Customer Service (877- 884-5167) as soon as possible for replacements. **DO NOT** turn your machine ON if any of these items are missing. You may cause injury to yourself or damage to the machine.
2. Report any shipping damage to your local distributor. Take photographs for any possible insurance claims.
3. With the help of another person, carefully lift the Bandsaw from the packaging and place it on a level floor.
4. Clean all rust protected surfaces with ordinary house hold type grease or spot remover. Do not use; gasoline, paint thinner, mineral spirits, etc. These may damage painted surfaces.
5. Apply a coat of paste wax to the table to prevent rust. Wipe all parts thoroughly with a clean dry cloth. Be careful, as the pre-installed bandsaw blade has sharp teeth and may cause injury if touched.
6. Set packing material and shipping carton aside. Do not discard until the machine has been set up and is running properly.

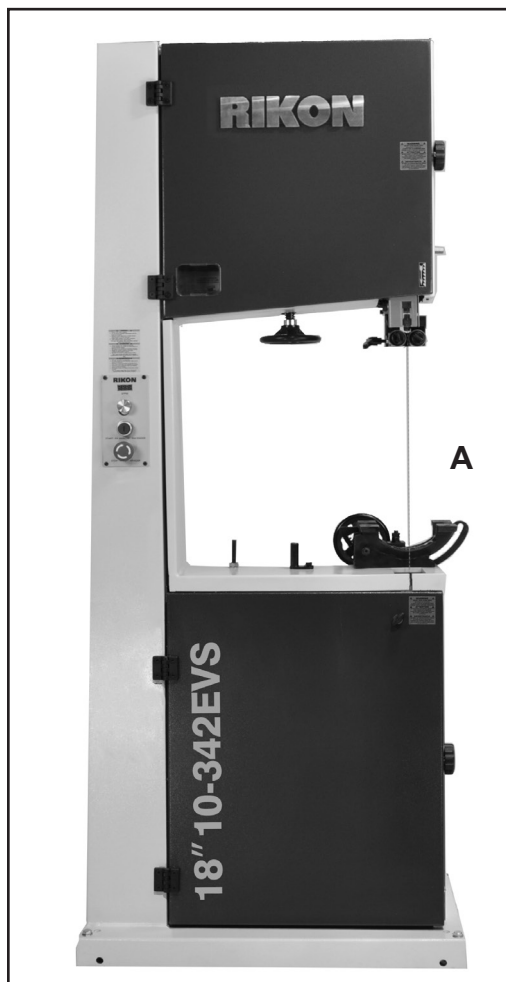
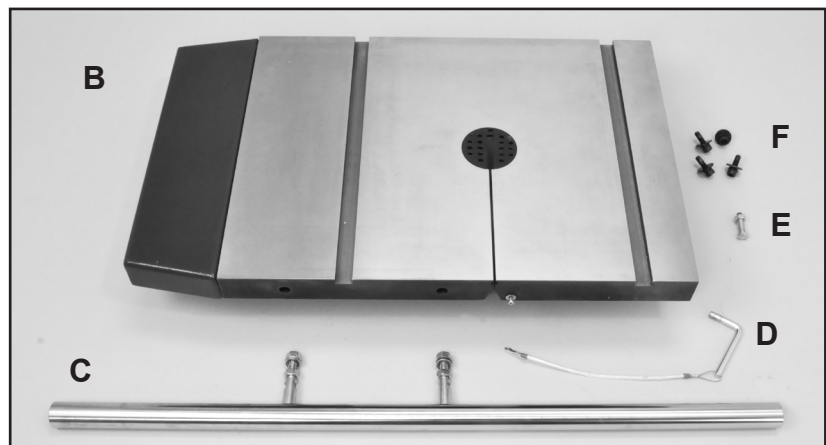

TABLE OF LOOSE PARTS

- A. Bandsaw Frame Assembly
- B. Table with Extension and Blade Insert
- C. Rip Fence Front Rail and Hardware
- D. Leveling Pin and Lanyard
- E. Table Leveling Bolt and Nut
- F. Table Mounting Bolts and Washers
- G. Manual and Warranty Card - not shown



Link to RIKON website,
10-342EVS Product Page



CONTENTS OF PACKAGE

TABLE OF LOOSE PARTS continued

Rip Fence Assembly & Parts:

- A. Rip Fence
- B. Rip Fence Carrier Assembly
- C. Push Stick and Mounting Bolt and Nut
- D. Hanger Bolts for Tow Bar (accessory item)
- E. Re-saw Bar Assembly

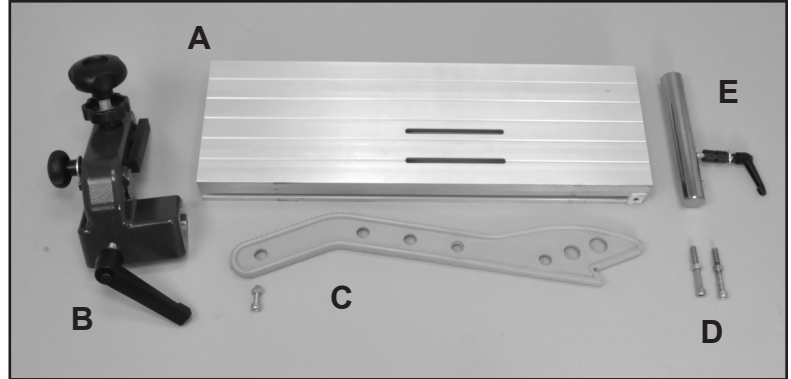

Parts for Assembly on Frame:

- F. Dust Port & Mounting Screws
- G. Handwheels (2)
- H. Handles for Handwheels (2)
- I. Lower Blade Guard and Knob

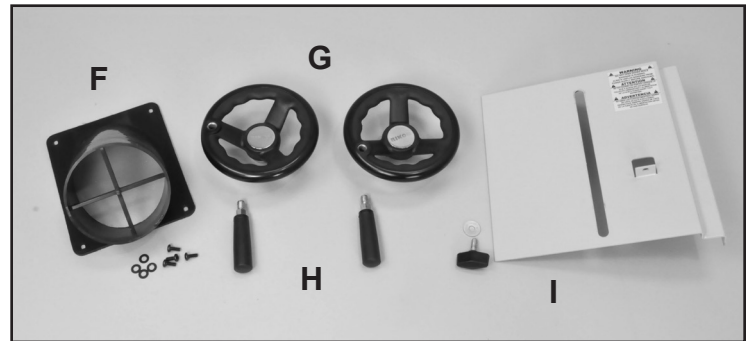

Tools and Tool Holder:

- J. Wrenches: 10, 13 mm
- K. Hex Wrenches; 3, 4, 5, 6 mm
- L. Tool Holder and Mounting Screws

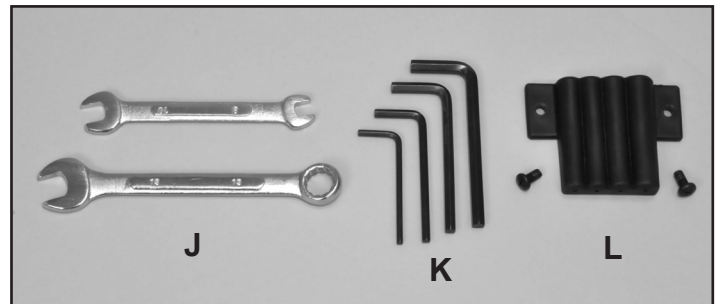

Additional Tools required - not supplied

- #2 Phillips Screwdriver
- 16mm or an Adjustable Wrench

INSTALLATION

MOVING & INSTALLING THE BANDSAW

CAUTION The bandsaw is heavy - over 300 lbs! It is best to assemble the machine near the area where it will eventually reside. When moving or positioning an assembled bandsaw, DO NOT use the table or upper blade guard assemblies as this may damage the machine. Move the bandsaw by grasping the support column and lower frame which are all welded together for rigidity. The bandsaw can also be moved by laying it down on the back/left side of the column so that the table assembly is not compromised.

1. Carefully remove the machine from the shipping carton. See above instructions on handling the saw.

2. Position the machine on a solid, level foundation that is located in an area that has ample space in front, right side and in back of the bandsaw for cutting large or long material.

For best power and safety, the bandsaw should be plugged directly into a dedicated grounded electrical outlet that is within the supplied cord length of the machine. The use of an extension cord is not recommended.

3. Align the machine so that during use, the material being cut will not face aisles, doorways, or other work areas that bystanders may be in. Do not locate or use the machine in damp or wet conditions.

4. Once in place in your shop, level the machine with spacers, and secure it to the floor with lag screws (not supplied) using the 4 holes in the saw's base.

ASSEMBLY

WARNING THE MACHINE MUST NOT BE PLUGGED IN AND THE POWER SWITCH MUST BE IN THE OFF POSITION UNTIL ASSEMBLY IS COMPLETE.

NOTE: Parts referenced throughout the manual refer to the different sheets and key numbers of the Parts Diagrams and Parts Lists on pages 28 to 37. Example: (#1A) refers to Part #1 on Sheet A.



FIGURE 1

TABLE ASSEMBLY

1. Mount the table (Fig. 1) in place on the trunnion with the assistance of another person. The table is heavy! Do this from the rear of the machine, so that it is easier to fit the pre-installed blade through the slot in the table.

2. Attach the table to the trunnion with the four Hex Socket Cap Screws, Spring Washers and Washers (Parts #13B, 12B, 11B). Install two bolts to the right of the blade, hand tightened only. Fig. 2. Then tip the table to 45 degrees and install the two bolts to the left of the blade. Fig. 3. DO NOT fully tighten the bolts at this time. Return the table to the horizontal position.

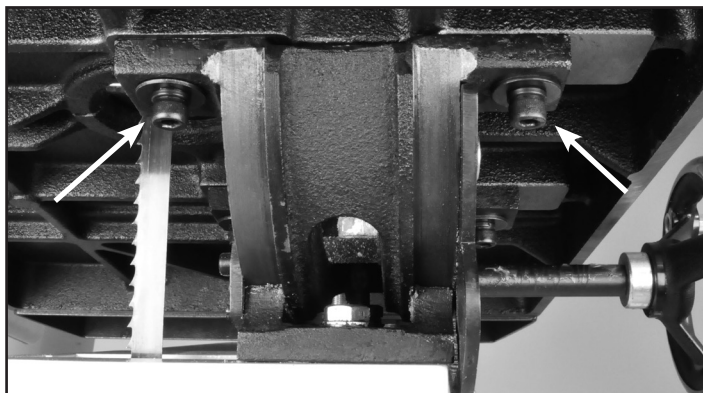

FIGURE 2

NOTE: Before finally secured in position, the table can be slightly moved, left and right. Check to make sure that the table's miter gauge slot is parallel to the side of the saw blade. This will provide a true cut when ripping stock. Set a thin metal ruler against the side of the saw blade. Make sure that it is not touching the saw's teeth, which can angle the ruler. Measure the distance from one end of the ruler to the miter gauge slot. FIG. 4. Then measure the same distance from the other end of the ruler to the miter gauge slot. Compare these two measurements and angle the table as necessary until the distances are the same.

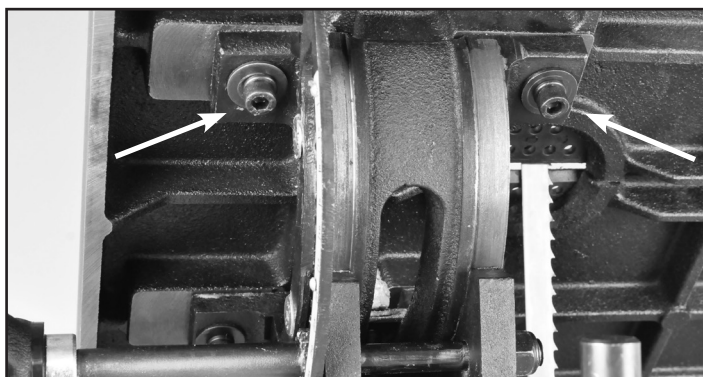

FIGURE 3

3. Once the table is aligned parallel to blade, tighten all four of the installed bolts to secure the table in place.

4. Attach the Table Leveling Pin's Lanyard (Part #5B) to the front of the table with the supplied Phillips Screw and Washer. This metal pin keeps the two sides of the table level at the slot area.

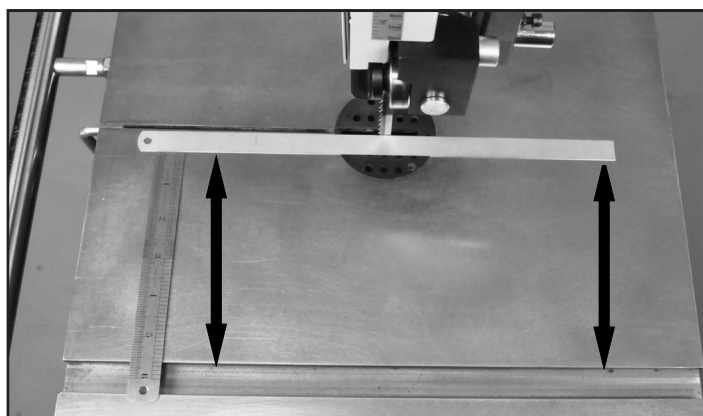
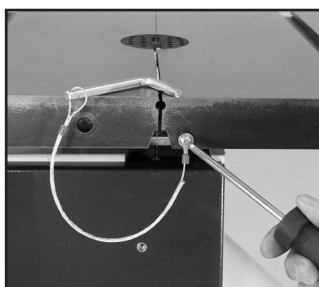

FIGURE 4

ASSEMBLY

RIP FENCE ASSEMBLY

1. Mount the fence Guide Rail (#12E) onto the front table edge with the two fence bar Nuts and Washers (#14E, 5E) Fig. 5. Position the bar so that it is parallel with the table surface, and equal distance out from the front edge of the table when measured at both left and right front edges of the table.
2. Slide the Fence Carrier Assembly (#9E) onto the fence's guide rail. Fig. 6.
3. Slide the Rip Fence (#18E) onto the fence carrier, and lock it in place by tightening the fence lock Knob (#7E) which is located on the carrier, opposite side to the fence. Fig. 6, A.
4. With the front Locking Handle (#10E, Fig. 6,B) secure the fence on the rail so that it does not move during the rest of the assembly process. Final adjustments to the fence are covered on pages 18 to 20. Information on the re-saw bar is on page 21.



FIGURE 5

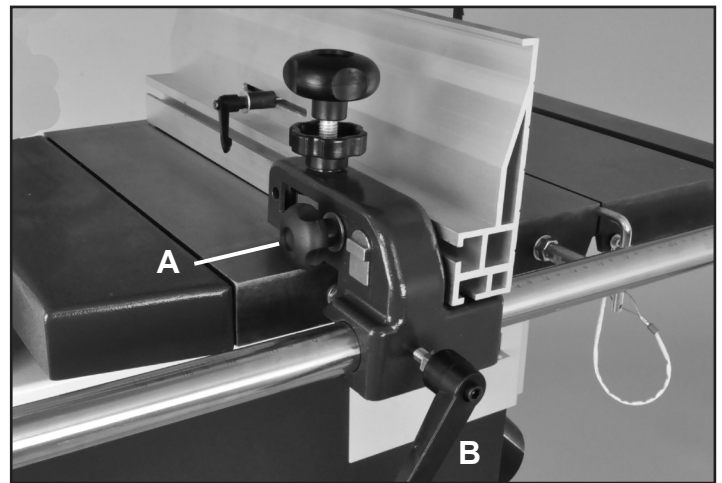
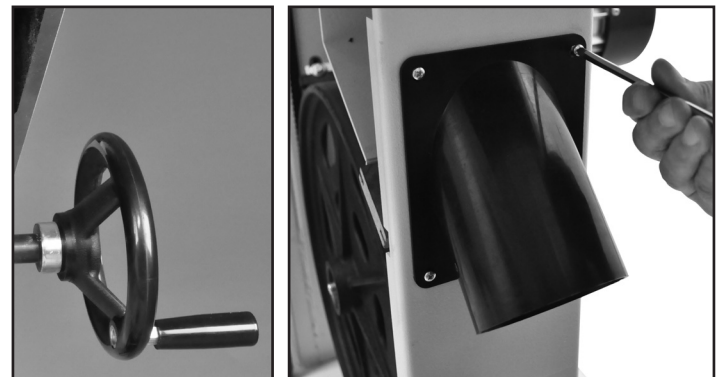

FIGURE 6

INSTALL THE HAND WHEELS

1. Attach the small Handle (#25B) to the large Handwheel (#24B) that tilts the table. Then install this handwheel onto the Gear Shaft (#23B) extending out from the trunnion at the back of the machine. Fig. 7A.
2. Attach the second small Handle to the Handwheel (#38C) that has been pre-installed at the upper right side of the saw frame. This wheel raises and lowers the blade guard.



A

FIGURE 7

B

INSTALL THE 4" DUST PORT

Mount the 4" Dust Port (#53A) under the table on the right side of the saw frame with four pan head screws and flat washers (#51A, 52A) using a Phillips screw driver. Fig. 7B.

INSTALL THE LOWER BLADE GUARD

Attach the Blade Guard (#19A) to the front of the lower door with the Handle and Washer (#17A, 18A). Slide the guard up to protect the lower guides during use, and slide the guard down when adjusting the lower guides is needed. Fig. 8A.

INSTALL THE 90° TABLE STOP

1. Tilt the table to gain access to its underside.
2. Thread the Hex Screw (#9B) and Nut (#8B) to the bottom of the table in the pre-bored and tapped hole. Fig. 8B. Setting the table to 90° to the blade will be done later on pages 12 and 13.

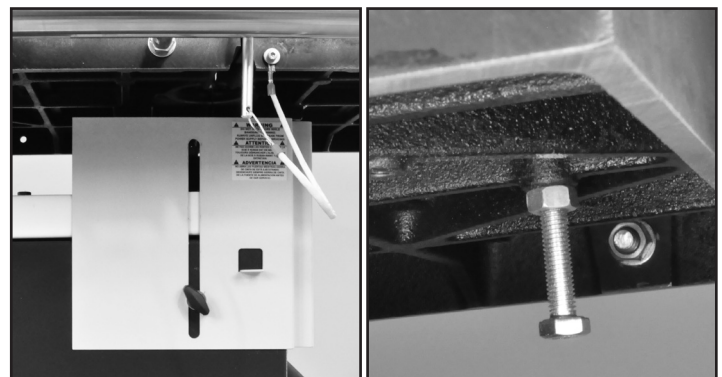

A

FIGURE 8

B

ASSEMBLY

INSTALL THE TOOL HOLDER

Assemble the Tool Holder (#68A) to the column rear with two Phillips Screws. Fig. 9, A.
Handy storage for the Hex Wrenches (3, 4, 5, 6mm).

INSTALL THE PUSH STICK HOLDER

Assemble the Push Stick Hanger Bolt (#4A) to the column's left side with a 5mm hex wrench. Handy storage for the push stick when not in use. FIG. 9, B.

INSTALL THE TOW BAR HOLDER

Two bolts (#4A) are included to store the tow bar included with the optional Mobility Kit #13-345. Screw the bolts into the column's left side. Fig. 10, C.

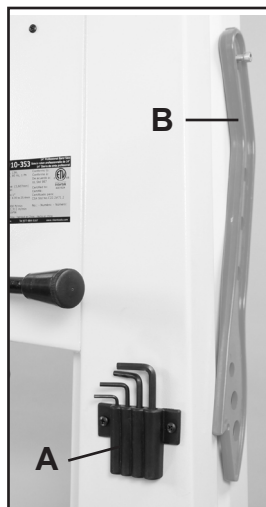

FIGURE 9

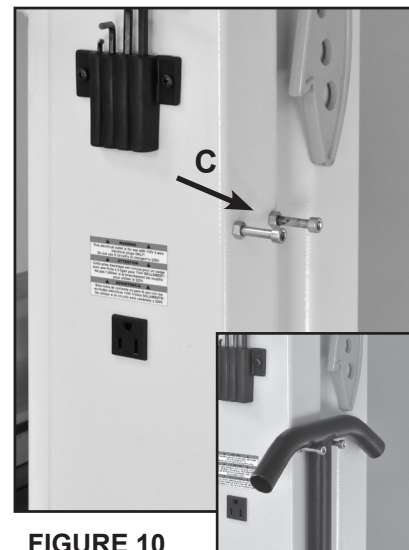

FIGURE 10

ADJUSTMENTS



WARNING THE MACHINE MUST NOT BE PLUGGED IN AND THE POWER SWITCH MUST BE IN THE OFF POSITION UNTIL ALL ADJUSTMENTS ARE COMPLETE.

TILTING THE TABLE

1. At the rear of the saw, loosen the Quick Locking Handle (#74A) on the table trunnion by pulling it upward. Fig.11, A.
2. Turn the table tilting Handwheel (#24B) to adjust the table to the desired angle. Fig. 11, B. Use the angle indicator scale (#32B) on the trunnion bracket (#27B) to find the desired angle, Fig. 11, C.
3. Retighten the lock handle to secure the table.

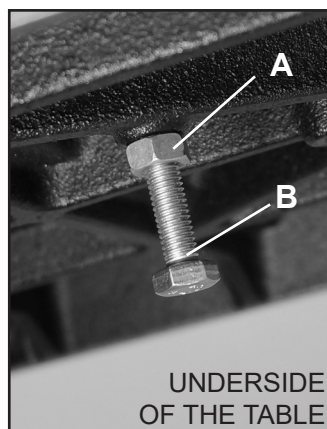

FIGURE 11

SETTING THE TABLE SQUARE TO THE SAW BLADE'S SIDE

The table may be set at 90° to the saw blade sides by adjusting the table stop Bolt (#9B) under the table. The table stop bolt rests on the top of the pivoting Stop Block (#62A).

1. First loosen the bolt's Locking Nut (#8B) Fig. 12, A.
2. Set a square on the table and against the saw blade's flat side. Tilt the table until the table is set exactly 90° to the blade, then lock the table in position.
3. Adjust the bolt (Fig. 12, B), up or down, until it is in contact with the pivoting Table Angle Stop Block (#62A) Fig. 12, C. Retighten the locking nut making sure that the table angle setting is maintained.



UNDERSIDE OF THE TABLE

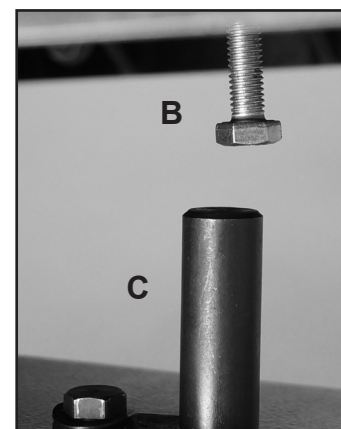

FIGURE 12

CONTINUED ON PAGE 13

ADJUSTMENTS

SETTING THE TABLE SQUARE TO THE SAW BLADE'S SIDE continued

4. The angle indicator on the trunnion, under the table at the rear of the machine, can be adjusted by loosening the Phillips head screw and moving the pointer into position to accurately indicate the 90°

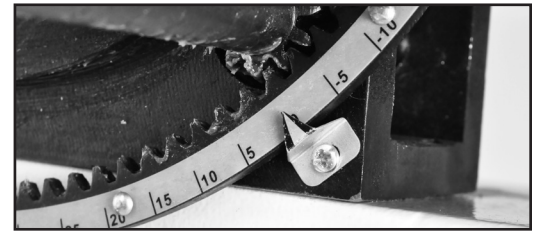

FIGURE 13

SETTING THE TABLE SQUARE TO THE SAW BLADE'S BACK

While pre-set before shipping, if needed, the table may also be re-set at 90° to the back of the saw blade by adjusting the trunnion's micro adjustment screws.

1. On the lower Trunnion Support (#18B), slightly loosen the two Hex Bolts (#14B) that hold the support to the bandsaw frame. Fig. 14, A.
2. Set a square on the table and against the saw blade's back, flat edge.
3. Using the 3mm hex wrench, turn the rear trunnion micro adjusting hex screws (#17B) to adjust the table position. Fig. 14, B.
 - *Clockwise* will raise the trunnion & table.
 - *Counterclockwise* will lower the trunnion & table.
4. Check the table and blade angle for 90° and when achieved, re-tighten the bolts to secure the table in position.

⚠ WARNING THE MACHINE MUST NOT BE PLUGGED IN AND THE POWER SWITCH MUST BE IN THE OFF POSITION UNTIL ALL ADJUSTMENTS ARE COMPLETE.

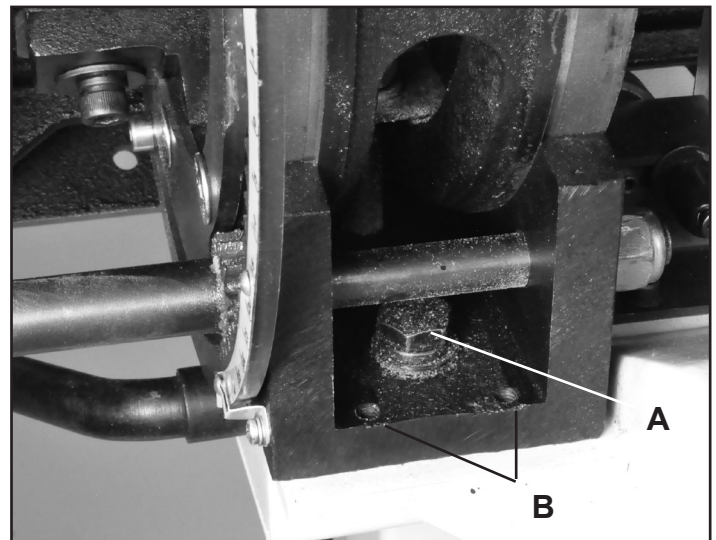

FIGURE 14

Photo of the micro adjusting screws shown with table angled for clarity.

TRACKING THE SAW BLADE

⚠ WARNING Unplug the bandsaw. A blade is installed at the factory. It is recommended to check the blade tracking prior to use. Make sure the upper and lower blade guides are adjusted away from the blade and the tension scale is set to correspond to the width of the blade you are using.

1. Open both doors. At the rear of the machine, loosen the Lock Lever (#27D, FIG. 15, A) by turning it counterclockwise.
2. Turn the Blade Tracking Handle (#28D, Fig. 15 B) clockwise or counterclockwise, while at the same time carefully turning the Upper Wheel (#1F) by hand. Reference Fig. 16, on page 14. Check the tracking of the blade on the wheel through the side window (C). Make at least three rotations of the wheel or until the blade tracks centered on the wheel.

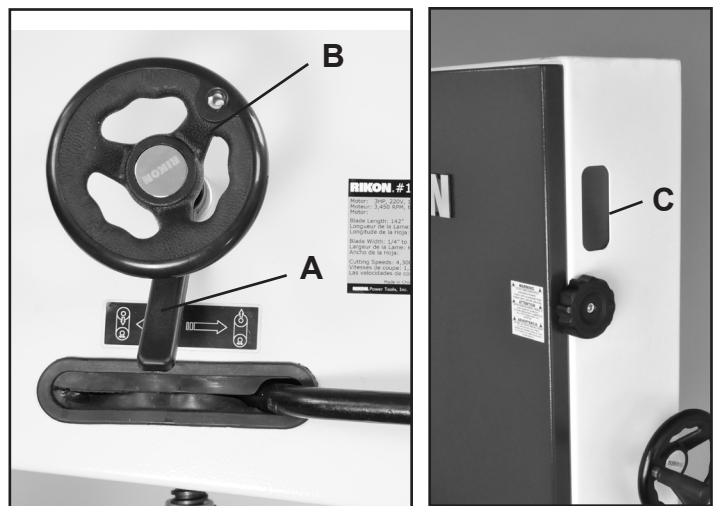

FIGURE 15

CONTINUED ON PAGE 14

ADJUSTMENTS

TRACKING THE SAW BLADE continued

3. Once the blade runs centered, tighten the lock lever and close the doors. For tracking of the blade on the Lower Wheel (#9F), see page 26 for instructions.

NOTE: the lower wheel has been pre-set at the factory and any changes made to this wheel should be after thorough reading and understanding of the instructions. Failure to do so could damage the machine.



FIGURE 16

ADJUSTING THE BLADE TENSION

CAUTION Always tension the blade with the Quick Release Lever (#19D) in the “ON” position. Failure to do so could result in lack of blade tension or tension failure. Figure 17.

NOTE: Release / turn ‘OFF’ the Tension Lever ONLY to change the blade, or to prolong the life of the blade when the saw is not in use for extended periods.

1. To adjust the blade tension, turn the Blade Tension Handwheel (#17D, Fig. 18, A).

To tighten the tension of the blade, turn the hand wheel clockwise. Tension the blade until the Tension Indicator Arrow (#6A, Fig. 18, B) corresponds to the width of blade you are using. View the indicator Arrow through the top door’s front window.

NOTE: The blade tension scale may read differently due to different blade specifications from manufacturers - steel thickness, material, or variations in the welded blade length. It may be necessary to adjust the tension arrow up/down one size on blade tension scale to match your blade. Note the blade setting for the next time the same blade is used.

General Rule for blade tension: With the saw unplugged and the blade guard up, the saw blade should deflect about 1/4” when pressed with a finger to the side of the blade.



FIGURE 17

WARNING THE MACHINE MUST NOT BE PLUGGED IN AND THE POWER SWITCH MUST BE IN THE OFF POSITION UNTIL ALL ADJUSTMENTS ARE COMPLETE.

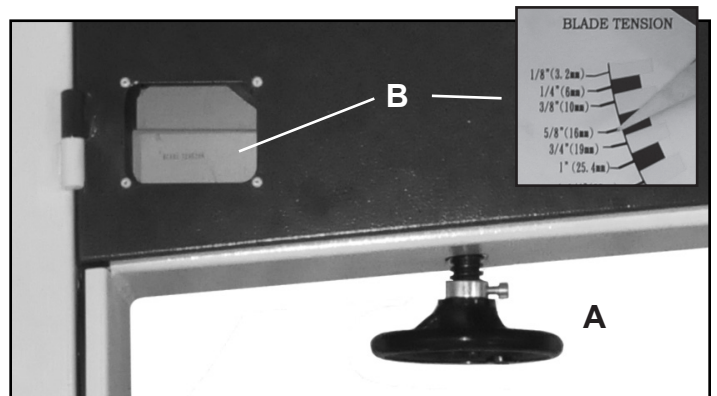
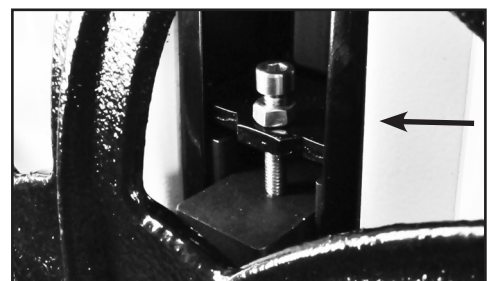

FIGURE 18

ADJUSTING THE BLADE TENSION STOP

If you can not set full tension on a new blade, the blade is most likely welded a bit longer than the standard 153” length, and so just beyond the pre-set tensioning range of the saw. To fix this, behind the top bandsaw wheel is Set Screw (#1D). Loosen the Nut (#2D) and turn the screw upward about 1/4”, then retighten the securing nut. This will increase the blade tensioning range of the saw for your new blade.



ADJUSTMENTS

ADJUSTING THE BLADE TENSION INDICATOR

The Blade Tension Indicator Arrow should be checked and adjusted the first time the saw is set up and run, and whenever a new blade is installed.

The blade tension indicator should be adjusted for blades made from thicker steel, if over cut or undercut in length, or made by different manufacturers.

1. With desired tension on the blade, loosen the top adjusting Screw (#8A) with a Phillips screwdriver. Fig. 19.
2. Adjust the blade indicator up/down as needed and then re-tighten the screw.

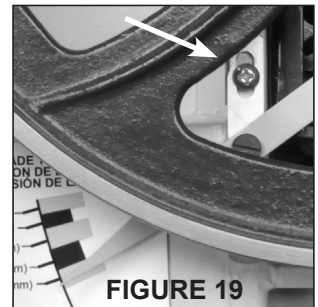

CHANGING THE BANDSAW BLADE

WARNING Unplug the machine from the electrical supply to ensure that the Bandsaw will not accidentally turn on if the ON/OFF switch is bumped.

1. Release the blade tension by moving the quick release lever from the right to the left (OFF). Fig. 20.
2. Open the top and bottom wheel doors, and remove the table support pin from the table front edge, and Dust Board (#33A, Fig. 21, G) by the lower dust port.
3. Open the Hinged Door (#11C) on the blade guard by loosening the Locking Handle (#14C). Fig. 21, A.
4. Remove the saw blade from the top wheel then feed it through the upper blade guides (B), slot in the table (C), lower blade guides (D), out of the slot in the column of the machine (E), off of the bottom wheel, and then around the front rail (F).

CAUTION Be careful not to cut yourself on the sharp saw teeth. Wear gloves for protection.

5. When installing the new blade, reverse the steps 1-4 above. Ensure that the blade teeth are pointing downwards and towards you at the position where the blade passes through the table.
6. Center the blade on both wheels.
7. Re-tension the new blade by moving the quick release lever back to the ON position, Fig. 20, and check the blade tracking. The blade should run in the center of the wheels. Refer to 'Tracking the Saw Blade' on pages 13 and 14 for more details.
8. Reset the blade guides as described in the section "Adjusting the Blade Guides" on pages 16 and 17.
9. Reset the blade tension as described in the section 'Adjusting the Blade Tension' on page 14.
10. Close the hinged door on the blade guard and tighten the locking handle to keep the door closed.
11. Close and lock both the wheel doors before reconnecting the power supply.



WARNING THE MACHINE MUST NOT BE PLUGGED IN AND THE POWER SWITCH MUST BE IN THE OFF POSITION UNTIL ALL ADJUSTMENTS ARE COMPLETE.

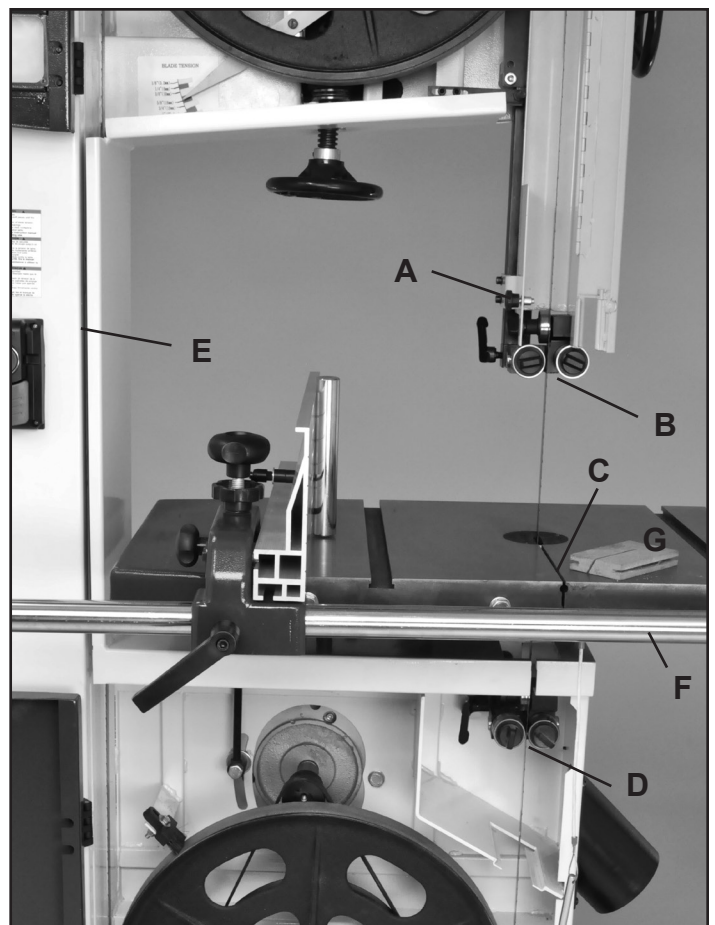

ADJUSTMENTS

ADJUSTING THE BLADE GUIDES

The 10-342 Bandsaw features quick-adjusting, spring loaded, ball bearing blade guides for fast and easy setting to the blades. With the bandsaw blade properly centered on the drive wheels, the guide bearings can then be set. To adjust the blade guides:

Upper Guides:

1. Position the right and left roller guides relatively close to the blade. First, loosen their front Lock Handles (#21C, Fig 22, A). The Guide Shafts (#25C) that hold the guide bearings are spring loaded! To move the guides towards the blade, simply push the ends of the guide shafts (B), or use the front lock handles to pull the guides towards the blade. Lock the guides in place with the front handles. Fig. 22.

2. The guides should be approximately 1/16" behind the gullets of the saw blade. If they need to be moved, loosen the back Clamp Handle (#31C, Fig. 23, C) and move the Upper Guide Block (#20C, D) that holds the guides so that the guides are properly positioned behind the blade gullets. Re-tighten the handle when done. Fig. 23.

3. Set both bearing guides to within 1/32" of the saw blade - about the same thickness of a business card. Do not set the bearing guides too close, or touch the sides of the blade, as this will adversely affect the life of the saw blade and bearings.

4. Adjust the rear bearing guide (Fig. 23, E) to be just clear of the back of the saw blade. Release the guide's Locking Handle (#17C, F) and move the rear guide towards the blade by pushing the end of the Rear Guide Shaft (#27C, Fig. 24, G) located at the rear of the block. Tighten the handle when done.

Lower Guides:

Adjusting the lower ball bearing guides, that are below the table, is similar to the steps taken for the upper guides.

1. Position the right and left roller guides close to the blade. Loosen the front Lock Handles (#38A, Fig. 25, A). Move the guides towards the blade by pushing the ends of the Guide Shafts (#42A, B), or use the front lock handles to pull the guides towards the blade. Lock the guides in place. Fig. 25.

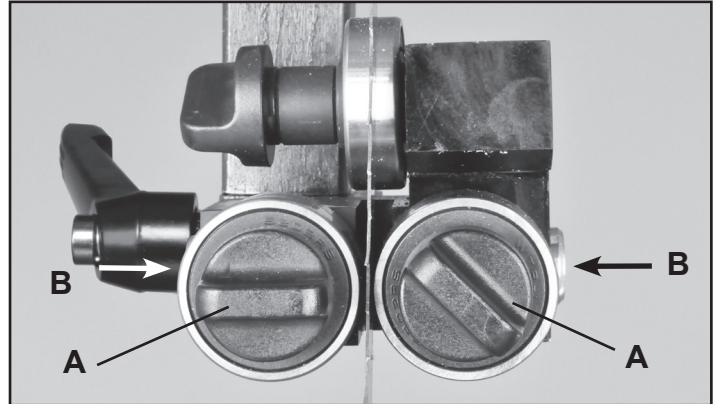

FIGURE 22 NOTE: Blade Guard removed for photo purposes

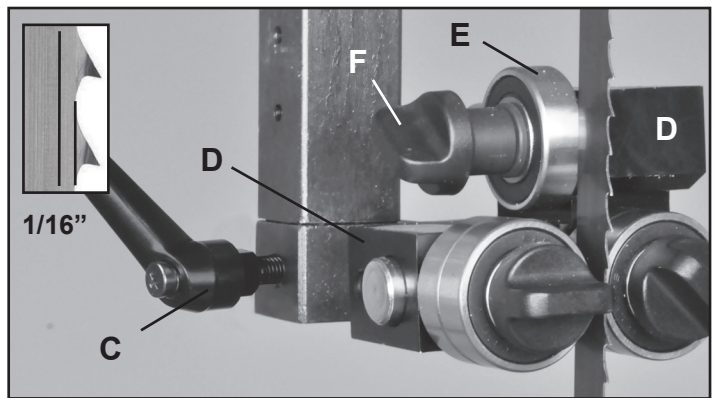

FIGURE 23 NOTE: Blade Guard removed for photo purposes

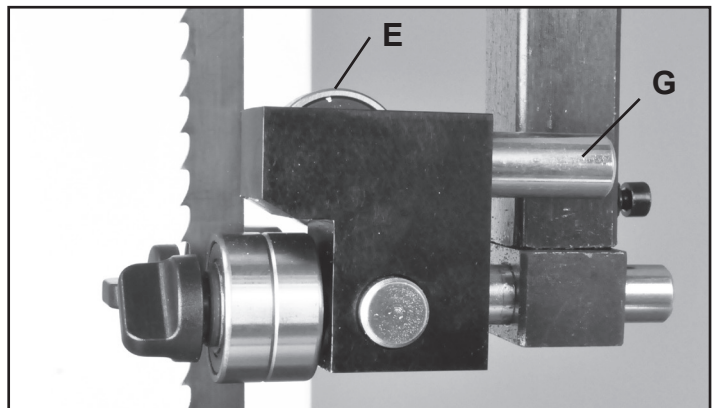

FIGURE 24 NOTE: Blade Guard removed for photo purposes

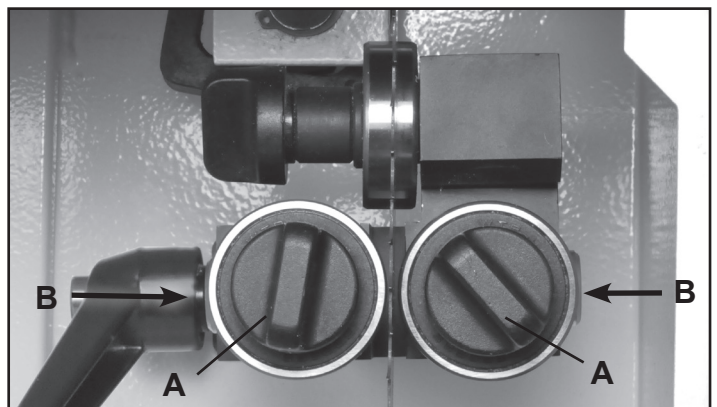

FIGURE 25

CONTINUED ON PAGE 18

ADJUSTMENTS

ADJUSTING THE BLADE GUIDES - continued

Lower Guides - continued:

2. The guides should be approximately 1/16" behind the gullets of the saw blade. If they need to be moved, loosen the Lock Handle (#47A, Fig. 26, A), located to the left of the Lower Guide Block (#44A, B), and move this block that holds the guides so that the guides are properly positioned behind the blade gullets. Re-tighten the lever handle when done.



FIGURE 26

3. Set both bearing guides to within 1/32" of the saw blade's sides - about the same thickness of a business card. Do not set the bearing guides too close, or touch the sides of the blade, as this will adversely affect the life of the blade and bearings.

4. Adjust the rear bearing guide to be just clear of the back of the saw blade. Release the guide's Locking Handle (Fig. 27, C) and move the rear guide towards the blade by pushing the end of the Rear Guide Shaft (#49A). This shaft extends through the bottom frame for easy access. Tighten the handle when done.

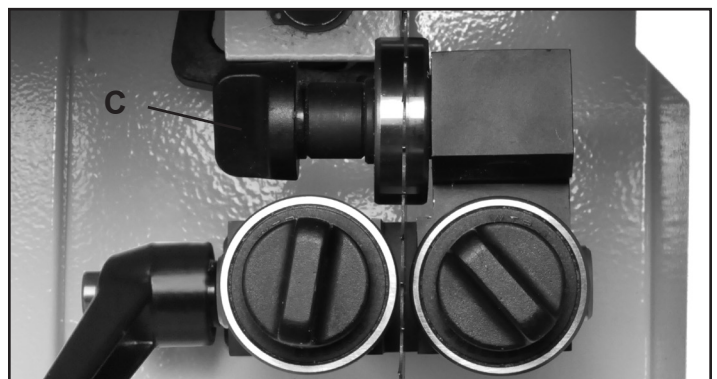

FIGURE 27 NOTE: Blade Guard removed for photo purposes

ADJUSTING THE BLADE GUIDE & GUARD

NOTE: Before cutting, set the upper guide bearings approximately 1/4" above the top surface of the work piece. This will give the best blade control. Fig. 28.

1. Loosen the Guidepost Lock Knob (#1C, Fig. 29A) and turn the Guidepost Handle (#38C, Fig. 30, B) to raise or lower the guide post/upper blade guide assembly to the desired height.

A measurement scale has been supplied on the right side of the guide post for quick reference on the height of the guide bearings above the table surface.

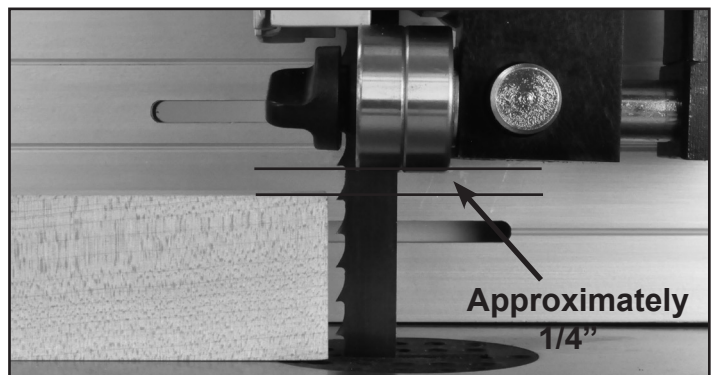

FIGURE 28

2. When the guide bearings are in proper position, re-tighten the guidepost lock knob.

NOTE: The guide post is pre-set at the factory to aligned vertical with the bandsaw blade. If the guide post setting ever needs slight adjustment:

3. Open the top door and lower the blade guard all the way down to the table to access the Guide Bracket (#4C). Fig. 31.

4. Loosen the four Hex Bolts (#2C) located at the rear of the top frame. (Fig. 29, C). This will allow the

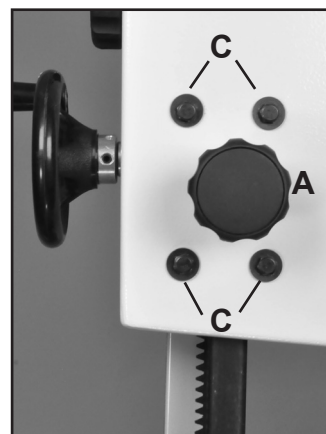

FIGURE 29

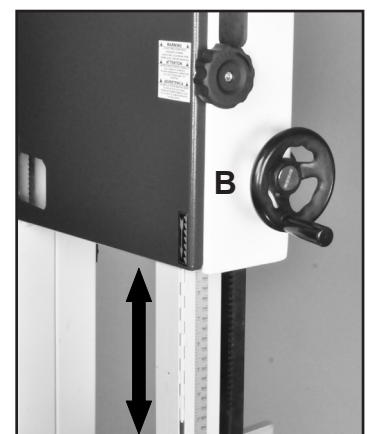

FIGURE 30

CONTINUED ON PAGE 18

ADJUSTMENTS

ADJUSTING THE BLADE GUARD - continued

guide post to be shifted/angled a bit left or right to correct any positioning issues.

5. There are also four Set Screws (#5C) set in the rear of the guide bracket near the corners. If the guard post needs to be angled slightly towards the front or back of the table, or even twisted on an angle, make the adjustment with these screws. Fig. 31.

- Advancing the top two set screws will angle the post towards the rear of the table.
- Advancing the bottom two set screws will angle the post towards the front of the table.
- Setting the two left or right screws will angle the post to the right or left.

6. When the post is adjusted vertical, tighten the four hex bolts that were loosened in step 4.

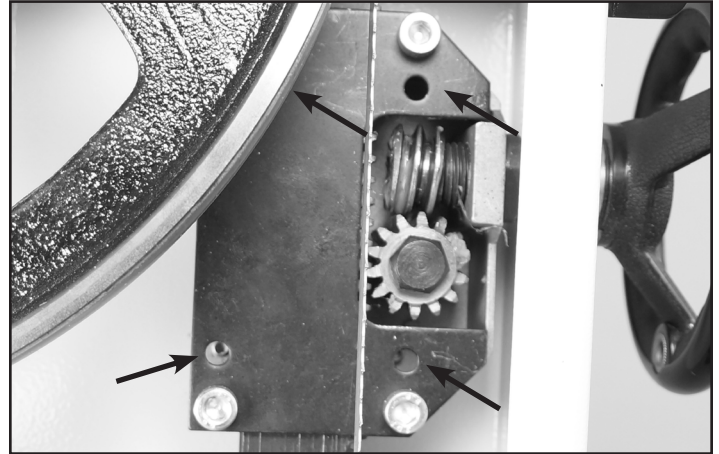

FIGURE 31 NOTE: Gear Guard removed for photo purposes

⚠ WARNING THE MACHINE MUST NOT BE PLUGGED IN AND THE POWER SWITCH MUST BE IN THE OFF POSITION UNTIL ALL ADJUSTMENTS ARE COMPLETE.

ADJUSTING THE RIP FENCE FOR DRIFT

The 10-342 Bandsaw features an innovative fence system that will easily adjust to eliminate 'drift', and bring the fence back to being parallel to the blade. Plus, it allows quick changing of the fence from a vertical to horizontal position, or for use to the left or right of the blade. To adjust the fence for drift:

1. Loosen the side Handle (#7E, Fig. 32, A) which holds the rip fence against the Fence Carrier (#9E, B).
2. Loosen the Locking Knob (#2E, Fig. 32, C).
3. Turn the top Adjusting Handle (#1E, D) to position the fence left or right as needed to align it parallel to the blade and miter saw slots in the table. The handle turns a Cam (#4E, E) that presses against the fence and pivots it as needed.
4. Once the fence is set, tighten the Handle and Knob that were loosened in steps 1 and 2.

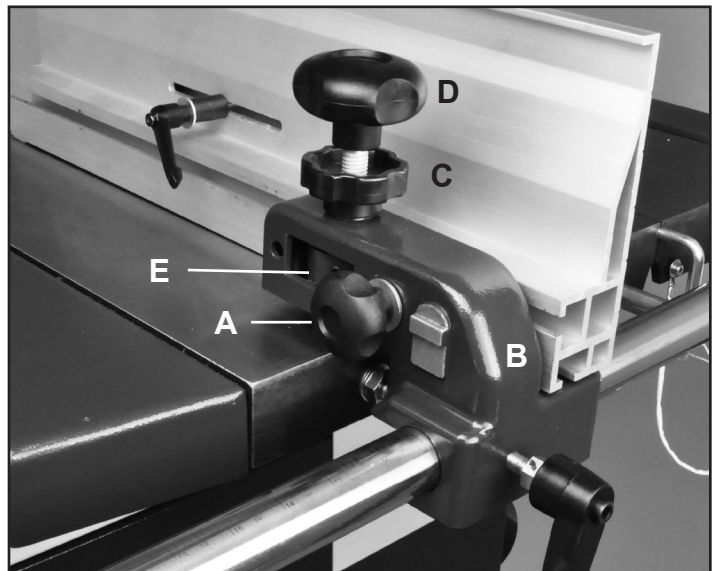

FIGURE 32

ADJUSTING THE FENCE 90° TO THE TABLE

Check that the fence is 90 degrees to the table using a suitable square. If adjustments are required, raise or lower either side of the fence's Guide Rail until the fence body is 90 degree to the table. Once set at 90 degrees, fully tighten the fence bar nuts. FIG. 33. See page 11 for the guide rail installation process.

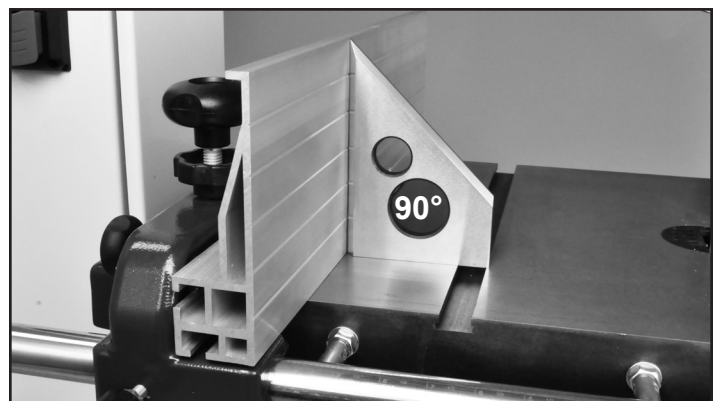

FIGURE 33

ADJUSTMENTS

ADJUSTING THE FENCE TO THE TABLE

Check that the fence is lying flat, or parallel to the table surface. The gap between the table and the bottom of the fence should be equal along the whole length of the fence. If a slight adjustment is necessary, the front rail will need to be adjusted - moving it up or down to raise or lower the fence distance over the table. Fig. 34.

Refer to page 11 for instructions on the mounting and re-positioning of the front fence rail.



FIGURE 34

ADJUSTING THE FENCE ON THE CARRIER

The fence can be changed from a vertical position to a horizontal position, or from its mounting on the left side of the blade to the right with simple adjustments of the carrier's handles and hardware.

To change the fence from vertical to horizontal:

1. Loosen the side Handle (#7E, Fig. 35, A) which holds the rip fence against the Fence Carrier (#9E, B).

2. Slide the fence forward to remove it from the carrier's Sliding Block (#11E, Fig. 35, C).

3. Turn the fence down to its horizontal position and slide it back onto the carrier. The bottom of the fence is slotted to mount on the sliding block, and position itself on the small, raised key (Fig. 35, D) on the side of the carrier. Fig. 36.

4. Once in place, retighten the side handle to secure the fence in position on the carrier.

5. Check the fence for drift, and make corrections if needed per instructions on page 18.

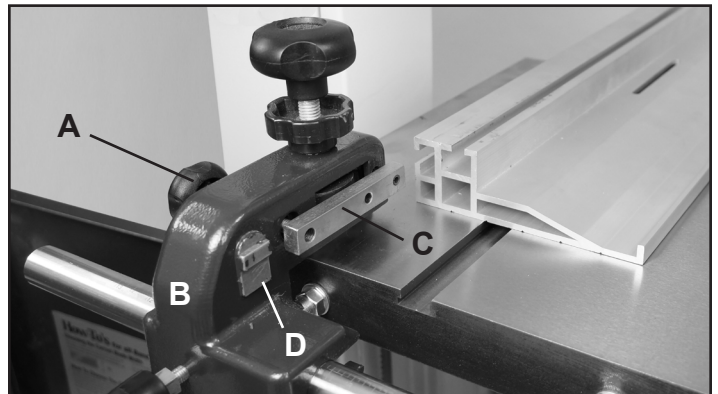

FIGURE 35



FIGURE 36

To change the fence from the left side of the carrier to the right side for using the rip fence to the right of the blade:

1. Loosen the side Handle (#7E, Fig. 35, A) which holds the rip fence against the Fence Carrier (#9E, B).

2. Slide the fence forward to remove it from the carrier's Sliding Block (#11E, C). Move the carrier on the front rail to the right side of the table and blade.

3. Fully unscrew the side handle from the sliding block and reassemble the parts on the opposite, left

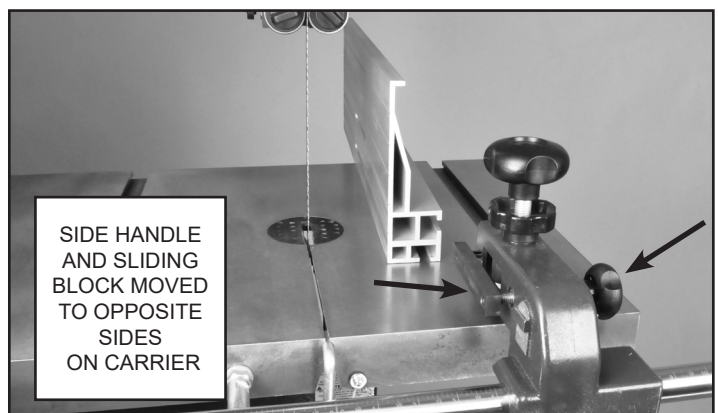

FIGURE 37

CONTINUED ON PAGE 20

ADJUSTMENTS

side of the carrier. Then rotate the fence 180° end-to-end and slide it back onto the carrier. Fig. 37 & 38.

4. Once in place, retighten the side handle to secure the fence in position on the carrier. Fig. 38.

5. Check the fence for drift, and make corrections if needed per instructions on page 18.

⚠ WARNING THE MACHINE MUST NOT BE PLUGGED IN AND THE POWER SWITCH MUST BE IN THE OFF POSITION UNTIL ALL ADJUSTMENTS ARE COMPLETE.

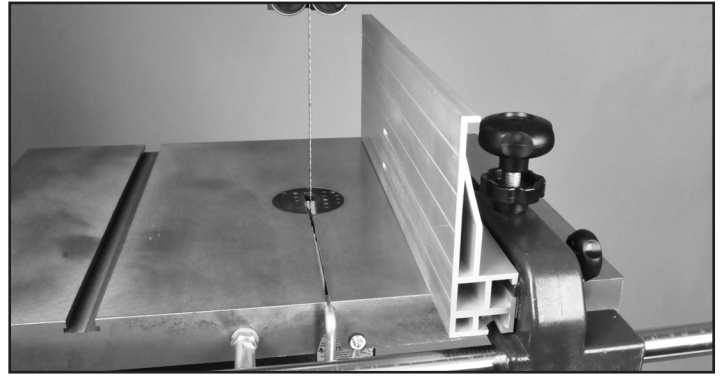

FIGURE 38

ADJUSTING THE DRIVE BELT TENSION

Check the Drive Belt (#10F, FIG. 39, A) tension with thumb pressure. The drive belt should not give more than 3/8" TO 1/2" in the center. DO NOT over tension the belt as this can put excessive, damaging pressure on the belt, pulleys and motor. Fig. 40.

To adjust the tension:

1. Loosen the two Hex Bolts (#25A, 27A, Fig. 39, B) that secure the motor to the frame.
2. Loosen the Hex Nut on the top of the Motor Pulling Rod (#26A, Fig. 39, C). The motor should now be loose to move downward for adjusting the belt.
3. For *less tension* on the drive belt, push the motor downward.
4. For *more tension* on the drive belt, lift the motor upwards. NOTE: There is a second hex nut on the motor pulling rod that is located *under* the frame. This second hex nut (Fig. 39, D) must be loosened to allow the motor to be lifted upwards.
5. When the belt tension is correct, tighten all the motor mounting nuts from steps 1, 2 and 4 above.

SEE PAGE 23 FOR INSTRUCTIONS ON CHANGING THE DRIVE BELT.

LEVELING THE TABLE INSERT

The table insert has an innovative, built-in micro adjustment feature to use if the insert sits too high or too low in the table seat. If the insert is resting *above* the table, turn the hex screws counter-clockwise to lower the insert. If the insert is sitting *below* the table surface, turn the hex screws clockwise to raise the insert level with the table surface. Fig. 41.

CAUTION: Having the insert below the table surface could cause the workpiece to get stuck on the lip of the table seat behind the blade, stopping your cut.



FIGURE 39

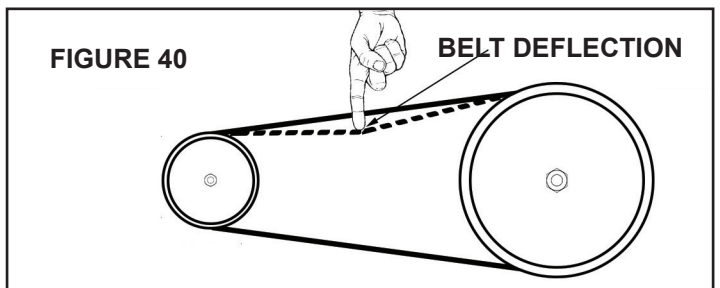

FIGURE 40

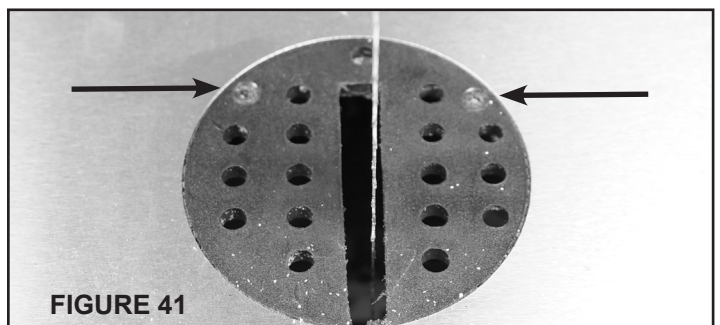

FIGURE 41

OPERATION

MAIN ON / OFF SWITCH

The 10-342EVS Wood/Metal Bandsaw has a main on/off switch located behind the saw on the side of the metal Inverter Box. FIG. 42. This switch **MUST** be operated before and after the saw is used.

It allows electrical access to the control box for using the saw. It also totally shuts down the saw when not in use for an extended time.

The switch protects the saw's electricals, particularly the LCD display from burning out, and prevents unwanted access by children or bystanders. The switch will also hold a lock to further secure the lathe from being activated.

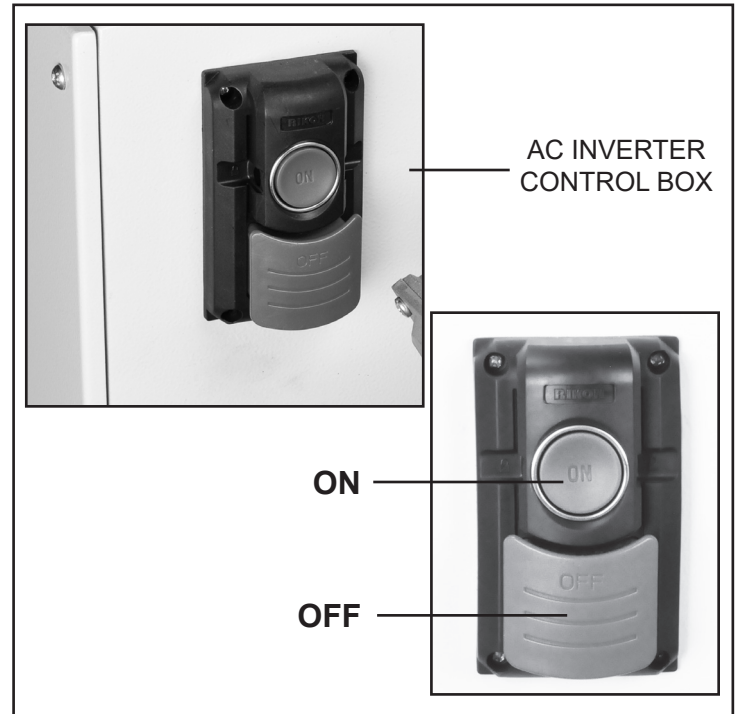

FIG. 42

CONTROL PANEL: ON/OFF SWITCH

In conjunction with the two speed pulley system, the 10-342EVS Wood/Metal Bandsaw also features a variable speed switch.

To use within a specific belt speed range, simply turn the bandsaw on (FIG. 43, A) and rotate the variable speed dial (B) clockwise to increase the speed, and counter clockwise to decrease the speed.

The blade speed will be indicated on the digital readout display (C).

To stop the bandsaw press the large red button (D).

NOTE: Rotate the large red stop button clockwise to reset the saw for next operation.

NOTE: The variable speed dial will only increase speed to the highest speed shown depending on belt position. FIG. 43.

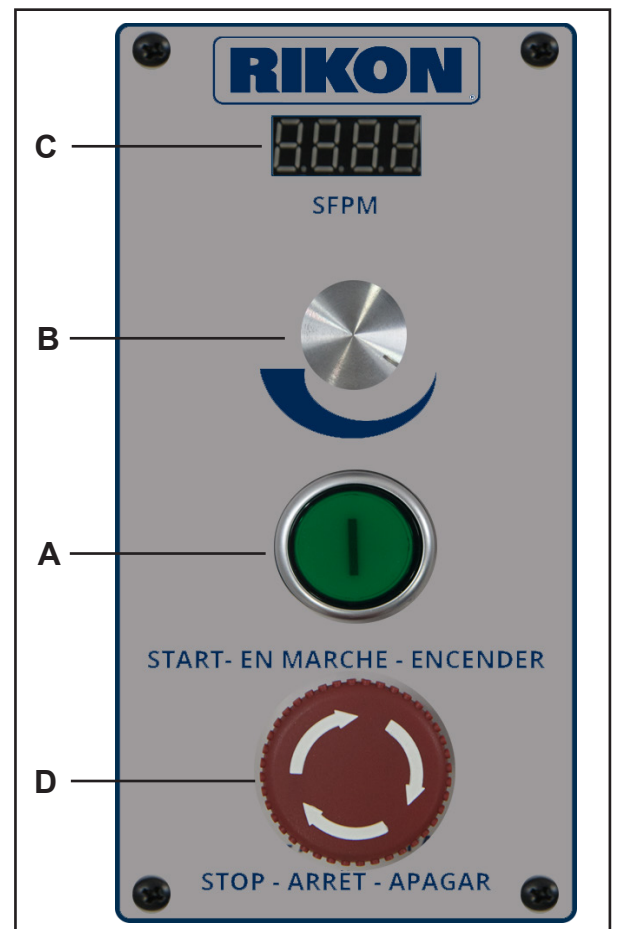

FIG. 43

OPERATION

METAL CUTTING

⚠ WARNING The 10-342EVS Wood/Metal bandsaw is designed for DRY CUTTING ONLY. Do not use lubricants or coolants with this bandsaw.

Proper blade selection for the material to be cut is key to good performance. Do not force the material into the blade as excessive heat will lead to premature blade failure. Poor cutting results will also occur. Always keep three teeth in the material being cut.

Stack or bundle cutting is not recommended with this bandsaw. When cutting round stock, use jigs or wedges to prevent the material from rolling into the cut.

Blade speed differs for each type or grade of metal to be cut. Below is a chart of common materials and the suggested blade speeds. The speeds shown have been reduced by 30% for dry cutting operations. It may be necessary to reduce an additional 15% due to material hardness. Changing blade type/style will also help performance.

METAL TYPE	BLADE SPEED -Ft/Min
Brass Alloys	140-154
Bronze Alloys	80-230
Cast Iron	80-157
Copper Alloys	112-206
Cr-Mo Alloy	136-164
Low/Med Carbon Steel	161-189
Stainless Steel	80-95

NOTE: Blade speed and performance depend on proper blade selection. Consult your blade manufacturer for the proper blade style and speed required for the material to be cut.

CUTTING PLASTIC/COMPOSITE MATERIAL

The 10-342EVS Wood/Metal bandsaw is also designed for cutting plastics and composite materials.

As always, selecting the proper blade for the material to be cut is key to getting good performance. Do not force the material into the blade as excessive heat will lead to premature blade failure and poor cutting results will also occur.

Stack or bundle cutting is recommended if the material is properly secured during the cut. When cutting round stock, use jigs or wedges to prevent the material from rolling into the cut.

Blade speed differs for each type of material to be cut. Improper blade selection and speed may result in melting or curling the material. Changing blade type/style will also help performance.

NOTE: Blade speed and performance depend on proper blade selection. Consult your blade manufacturer for the proper blade and speed required for the material to be cut.

OPERATION

ELECTRICAL OUTLET

On the rear of the bandsaw column below the tool holder, a 110V electrical outlet has been added to the machine for your working convenience. This outlet can be used with work lights (with magnetic bases or clips) to illuminate the work table and blade, for radios, charging phones or tablets, etc. FIG. 44.

CAUTION: Make sure that the cords of these devices do not interfere with any parts of the bandsaw.



FIGURE 44

WIRING DIAGRAM

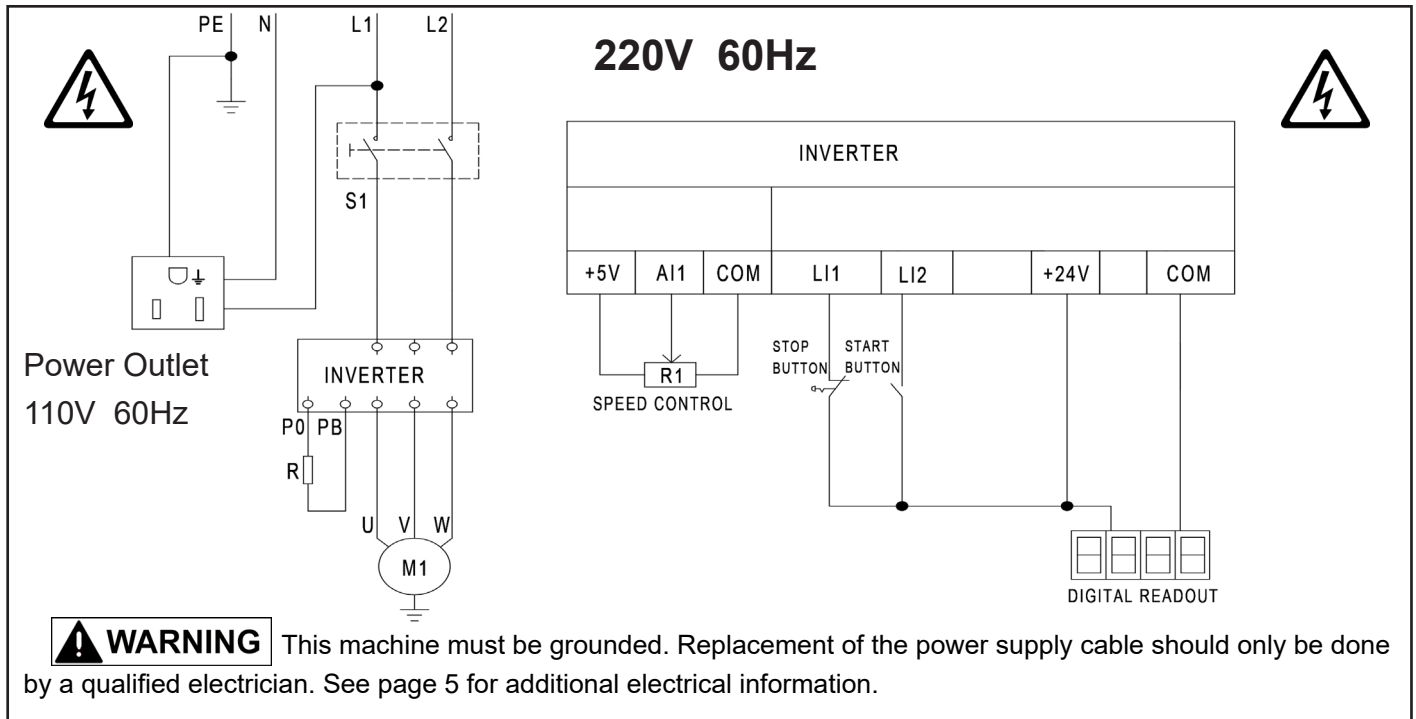

MAINTENANCE

CAUTION BEFORE CLEANING OR CARRYING OUT MAINTENANCE WORK, DISCONNECT THE MACHINE FROM THE POWER SOURCE (WALL SOCKET). NEVER USE WATER OR OTHER LIQUIDS TO CLEAN THE MACHINE. USE A BENCH BRUSH. DO NOT USE COMPRESSED AIR NEAR BEARINGS. REGULAR MAINTENANCE OF THE MACHINE WILL PREVENT UNNECESSARY PROBLEMS.

1. Keep the table clean to ensure accurate cutting.
2. Keep the outside of the machine clean to ensure accurate operation of all moving parts and prevent excessive wear.
3. Keep the ventilation slots of the motor clean to prevent it from overheating.
4. Keep the inside of the machine (near the saw blade, etc.) clean to prevent accumulation of dust. Use dust collection, if possible.
5. To prolong the life of the blade, when the bandsaw is not in use for extended periods, release the blade tension. Before reusing the bandsaw, ensure that the blade is re-tensioned and tracking is checked.
6. Keep the guide bearings free of dust, and clean the guide bearing assemblies frequently.

MAINTENANCE

⚠ WARNING: THE MACHINE MUST NOT BE PLUGGED IN AND THE POWER SWITCH MUST BE IN THE OFF POSITION UNTIL ALL ADJUSTMENTS ARE COMPLETE.

CHANGING THE MOTOR DRIVE BELT

Refer to “Frame Assembly” parts diagram on page 28, and “Motor & Drive Wheel Assembly” page 37.

1. Before changing the belt, make sure that the bandsaw is unplugged from the power source.
2. Release the saw blade tension from the drive belt by turning the quick release blade tension lever.
3. Release the drive belt tension by using the belt tension. See page 20 for Instructions.
4. Remove the lower wheel (Wheel Assembly, Part #9F) by removing the hex head bolt and washer (#7F, 6F) in the middle of the wheel’s hub. Carefully slide the lower wheel off of the lower wheel shaft, and at the same time remove the saw blade from this wheel.

⚠ CAUTION Be careful not to cut yourself on the sharp saw teeth. Wear gloves for protection.

5. Remove the old drive belt from the wheel’s pulley, and install the new belt. Make sure the ribs in the drive belt are seated correctly in the pulley before reassembling and tensioning the drive belt.
6. Reverse the procedure to re-assemble the saw parts. Tension the drive belt until there is 3/8” to 1/2” of deflection. See page 20 for instructions on ‘Belt Tensioning’.

CHANGING BANDSAW TIRES

Use a putty knife to get underneath the tire and pull it up and away from the wheel. Work the putty knife all the way around the wheel to loosen the tire. Then, use the putty knife as leverage to flip the tire over and off of the wheel. Clean the inside of the groove, removing any dirt, debris or cement with lacquer thinner.

Soak the replacement tire in warm water to make it more flexible. Dry the tire, and while it is still warm, lay it on top of the wheel. Start by setting the tire into the wheel groove at the top of the wheel. Using a putty knife, work the new tire around the wheel, making sure not to slice the tire. If rubber cement is to be used as a binder, make sure to distribute it evenly. Having high spots between the wheel and the tire will cause a vibration and effect blade tracking.

NOTES

Use this section to record maintenance, service and any calls to Technical Support.

TROUBLESHOOTING

⚠ WARNING FOR YOUR OWN SAFETY, ALWAYS TURN OFF AND UNPLUG THE MACHINE BEFORE CARRYING OUT ANY TROUBLESHOOTING.

TROUBLE	PROBABLE CAUSE	REMEDY
The machine does not work when switched on.	<ol style="list-style-type: none"> 1. No power supply. 2. Defective switch. 	<p>Check the cable for breakage. Contact your local dealer for repair.</p>
The blade does not move with the motor running.	<ol style="list-style-type: none"> 1. The quick release lever or blade tension handwheel has not been tightened. 2. The blade has come off one of the wheels. 3. The saw blade has broken. 4. The drive belt has snapped. 	<p>Switch off the motor, tighten the quick release lever or blade tension handwheel. Open the hinged door and check. Replace the blade. Replace the belt.</p>
The blade does not cut in a straight line.	<ol style="list-style-type: none"> 1. Fence for cutting not used. 2. Too fast feed rate. 3. The blade teeth are dull or damaged. 4. Blade guides not suitably adjusted. 	<p>Use a fence. Put light pressure on the workpiece & make sure the blade does not bend. Use a new blade. Adjust the blade guides (see the section on page 16 and 17).</p>
The blade does not cut, or cuts very slowly.	<ol style="list-style-type: none"> 1. The teeth are dull, caused by cutting hard material or long use. 2. The blade was mounted in the wrong direction. 	<p>Replace the blade, use a 6 T.P.I. blade for wood and soft materials. Use a 14 T.P.I. blade for harder materials. A 14 T.P.I. blade always cuts slower due to the finer teeth and the slower cutting performance. Fit the blade correctly.</p>
Sawdust builds up inside the machine.	<ol style="list-style-type: none"> 1. This is normal. 	<p>Clean the machine regularly. Open the hinged door and remove the sawdust with a vacuum cleaner.</p>
Sawdust inside the motor housing.	<ol style="list-style-type: none"> 1. Excessive dust build-up on the machine exterior components. 	<p>Clean the ventilating slots of the motor with a vacuum cleaner. From time to time remove the sawdust to prevent it from being sucked into the housing.</p>
The machine does not cut at 45° or 90° angles.	<ol style="list-style-type: none"> 1. The table is not at right angles to the blade. 2. The blade is dull or too much pressure was put on the workpiece. 	<p>Adjust the table. Replace the blade or put less pressure on the workpiece.</p>
The blade cannot be properly positioned on the bandwheels.	<ol style="list-style-type: none"> 1. The blade tracking knob hasn't been properly adjusted. 2. Inferior blade. 3. The wheels are not in alignment. 	<p>Adjust the tracking knob (see page 13). Replace the blade. Adjust the lower wheel (see pages 26 & 27) Contact Technical Support @ 877-884-5167 or techsupport@rikontools.com.</p>

For parts or technical questions contact: techsupport@rikontools.com or 877-884-5167.

TROUBLESHOOTING

LOWER WHEEL ADJUSTMENTS

The following instructions will correct common blade issues related to the lower wheel's alignment in relation to the upper wheel. These adjustments will correct the blade position on the lower wheel and blade oscillation (wobble). These are critical adjustments which affect the performance and accuracy of the bandsaw.

CAUTION PLEASE READ AND UNDERSTAND THESE STEPS THOROUGHLY BEFORE MAKING ANY ADJUSTMENTS. FAILURE TO DO SO COULD DAMAGE THE MACHINE.

Please contact a tech support representative if you have questions before attempting these adjustments. RIKON Tech Support 877-884-5167 techsupport@rikontools.com

Release the blade tension completely before making any lower wheel adjustments. Pressure must be released on the lower wheel to allow proper adjustments and to avoid damaging the machine.

If the blade is not running true, or it is not running on center of the lower wheel but is correct on the upper wheel, then an adjustment to the wheel hub on the rear of the bandsaw is required.

The numbers shown on the rear hub photo represent the positions on a clock face.

NOTE: To help identify the extent of rotation on a bolt, mark a black dot on the edge of the bolt as a visual indicator.

If a blade is tracking forward on the lower wheel toward the door, follow these correction steps:

- 1.) De-tension the saw blade.
- 2.) Loosen 9 o'clock shaft bolt to take pressure off the shaft.
- 3.) Loosen 12 o'clock shaft bolt one half rotation.
- 4.) Tighten the 6 o'clock shaft bolt until the shaft touches the 12 o'clock adjusting bolt.
- 5.) Lock all three shaft bolts.
- 6.) Re-tension the saw blade and set the upper wheel to plumb by adjusting the tracking knob. Spin the upper wheel by hand and track the blade.
- 7.) Repeat if further adjustment is necessary.

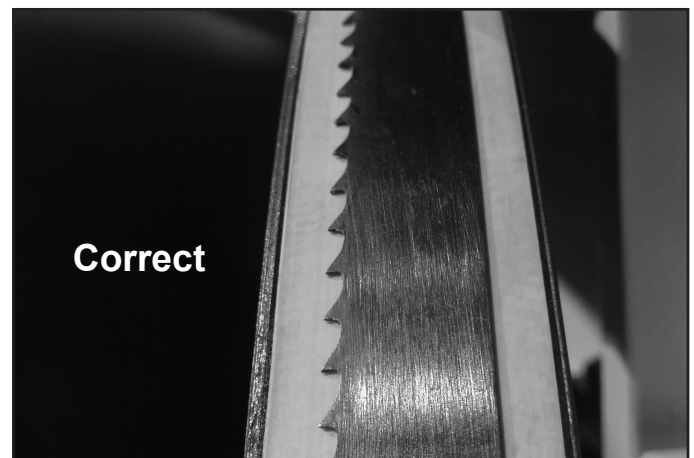
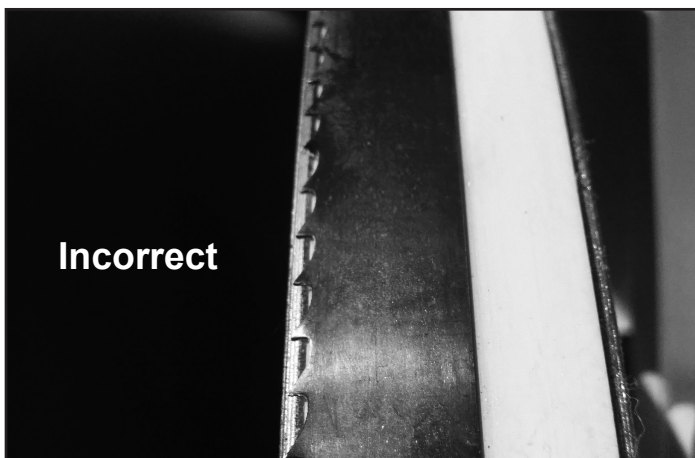
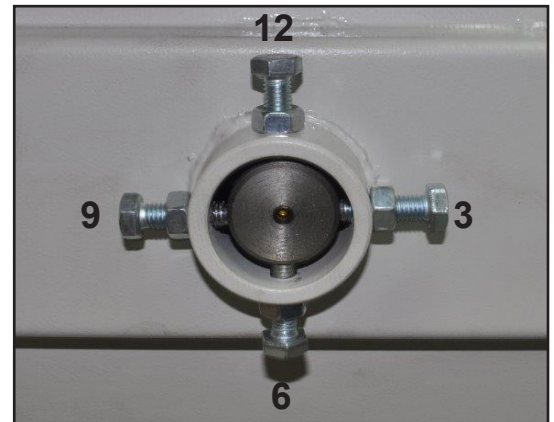

TROUBLESHOOTING

If a blade is tracking on the rear of the lower wheel away from the door, follow these steps:

- 1.) De-tension the saw blade.
- 2.) Loosen 9 o'clock shaft bolt to take pressure off the shaft.
- 3.) Loosen 6 o'clock shaft bolt one half rotation.
- 4.) Tighten the 12 o'clock shaft bolt until the shaft touches the 6 o'clock adjusting bolt.
- 5.) Lock all three shaft bolts.
- 6.) Re-tension the saw blade and set the upper wheel to plumb by adjusting the tracking knob. Spin the upper wheel by hand and track the blade.
- 7.) Repeat if further adjustment is necessary.

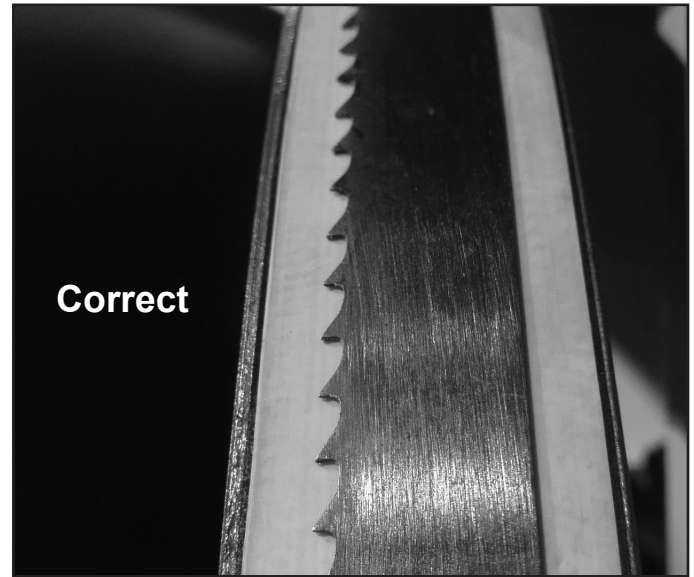
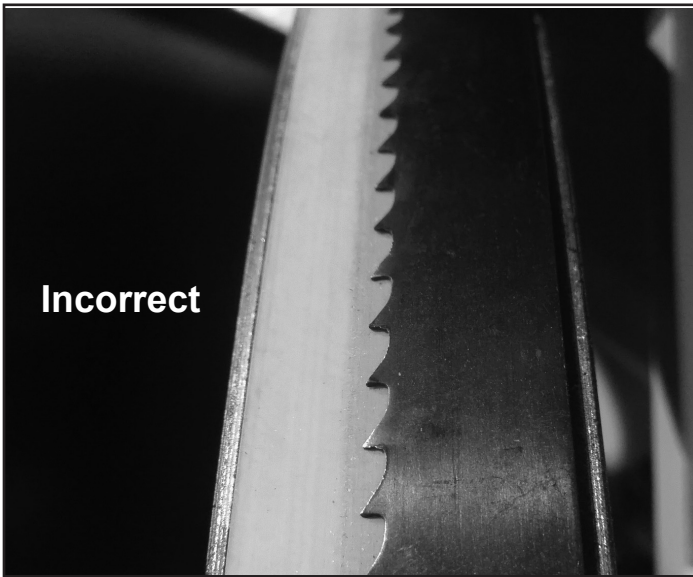

If a blade is moving back and forth (wobbling) follow these steps:

First, check the bandsaw blade to insure that it has been welded correctly, so that the blade's back is in proper alignment - flat (if it is laid down on a table surface).

If the blade is welded true, then adjustment to the wheel hub on the rear of the bandsaw is required.

- 1.) De-tension the saw blade.
- 2.) Loosen 6 o'clock shaft bolt to take pressure off of the shaft.
- 3.) Loosen 9 o'clock shaft bolt one half rotation.
- 4.) Tighten the 3 o'clock shaft bolt until the shaft touches the 9 o'clock adjusting bolt.
- 5.) Lock all three shaft bolts.
- 6.) Re-tension the saw blade and set the upper wheel to plumb by adjusting the tracking knob. Spin the upper wheel by hand and track the blade.
- 7.) Start the bandsaw and check blade movement.
- 8.) If movement has diminished then continue with the adjustment.
- 9.) If movement is worse, reverse the adjustments in steps 3 and 4.

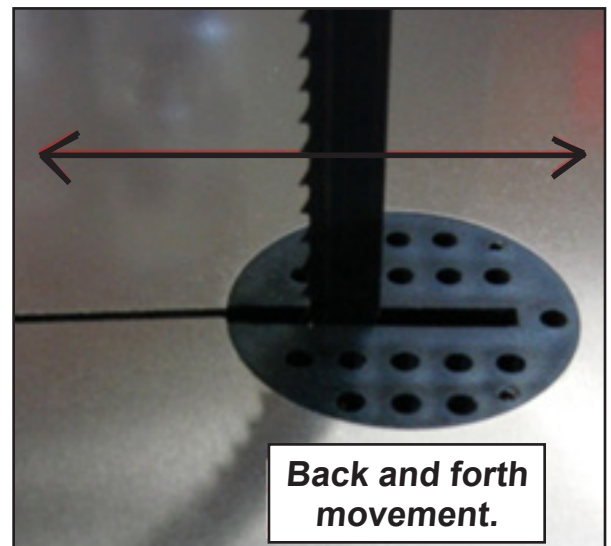

NOTE: Please reference the Manufacturer's Part Number when calling for Replacement Parts. For Parts under Warranty, the Serial Number of your machine is required.

FRAME ASSEMBLY SHEET A

PARTS DIAGRAM

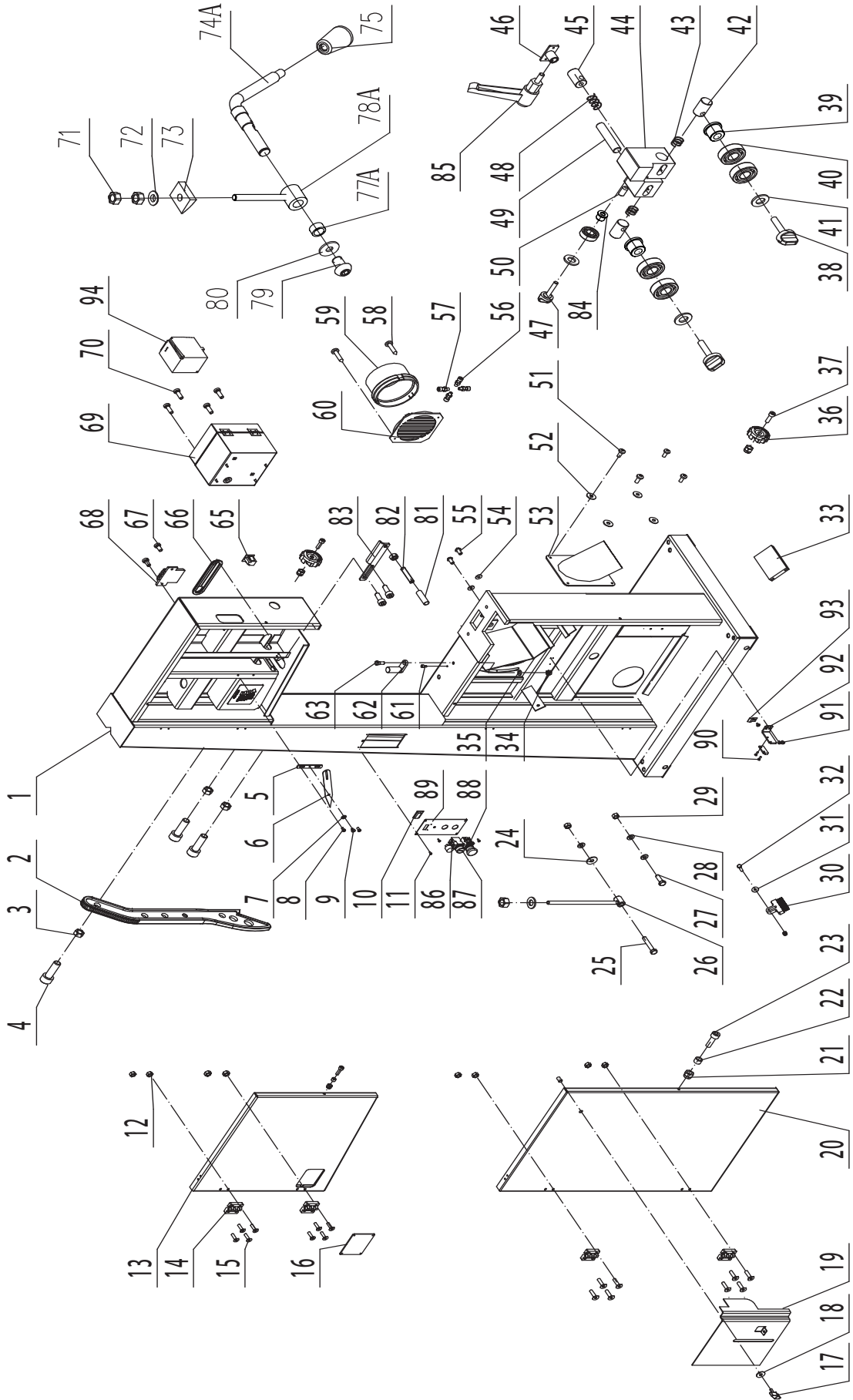

PARTS LIST

FRAME ASSEMBLY - SHEET A

KEY NO.	DESCRIPTION	QTY	PART NO.
1A	Frame	1	1-JMBS1801011000A-117U
2A	Push stick	1	1-JL81100003-146S
3A	Hex nut M6	3	1-M6GB6170B
4A	Hex bolt	3	1-M6X30GB70D1B
5A	Batter board	1	1-JL27010005
6A	Tension indicator arrow	1	1-JL26010004-002A
7A	Flat washer	1	1-WSH5GB97D1Z
8A	Pan head screw M5x10	2	1-M5X10GB818Z
9A	Special screw	1	1-JL26010010
10A	Digital display board	1	1-JMWL1203090008A
11A	Pan head screw M4x10	4	1-M4X10GB823B
12A	Hex nut with flange	8	1-M6GB6177B
13A	Upper door cover	1	1-JMBS1801012000A-076U
14A	Plastic hinge	4	1-EBBS1801010004
15A	Hex cap screw M6x20	16	1-M6X20GB70D3B
16A	Window	1	1-JXBS1804010004A
17A	Wing nut	1	1-JXBS2401054001-001S
18A	Big washer	1	1-WSH6GB96B
19A	Protective cover	1	1-JXBS1804012004-114X
20A	Lower door cover	1	1-JMBS1801013000A-076U
21A	Hex locking nut M6	5	1-M6GB889Z
22A	Cover	2	1-JL26010007
23A	Hex cap screw M6x20	2	1-M6X20GB70D1Z
24A	Big washer	1	1-WSH10GB96Z
25A	Hex bolt M10x60	1	1-M10X60GB5783Z
26A	Pull rod	1	1-JMBS1801014001
27A	Hex bolt M10x30	1	1-M10X30GB5783Z
28A	Flat washer	3	1-WSH10GB97D1Z
29A	Hex nut M10	3	1-M10GB6170Z
30A	Brush	1	1-JL21060003
31A	Big washer	3	1-WSH6GB96Z
32A	Hex bolt M6x25	1	1-M6X25GB5783Z
33A	Board	1	1-JXBS1804010002
34A	Hex locking nut M8	1	1-M8GB889Z
35A	Flat washer	1	1-WSH8GB97D1Z
36A	Star knob	2	1-JL26010006-001S
37A	Hex cap screw M6x25	2	1-M6X25GB70D1Z
38A	Lock handle	2	1-JMBS1801052002-001S
39A	Bearing sleeve	2	1-JMBS1801052003
40A	Bearing	5	1-BRG6202-2RSGB276
41A	Washer	3	1-WSH8GB96B
42A	Guide shaft	2	1-JMBS1403014003
43A	Spring	2	1-JMBS1403014005
44A	Lower guide block	1	1-JMBS1801052001
45A	Adjust bar	1	1-JMBS1801016001
46A	Guide frame	1	1-JMBS1801010001
47A	Locking handle	1	1-JMBS1403014006-001S
48A	Spring	1	1-JMBS1401014008

KEY NO.	DESCRIPTION	QTY	PART NO.
49A	Guide supporting rod	1	1-JL26041004
50A	Cap screw M8x10	1	1-M8X10GB80B
51A	Pan head screw M4x10	4	1-M4X10GB818B
52A	Big washer	4	1-WSH4GB96B
53A	Dust port	1	1-JXBS2401010013
54A	Big washer	2	1-WSH6GB96B
55A	Screw M6x12	2	1-M6X12GB70D2B
56A	Hex bolt M12x40	4	1-M12X40GB5783B
57A	Hex nut M12	4	1-M12GB6170B
58A	Tapping screw	2	1-ST3D5X9D5GB845B
59A	Dust port	1	1-JL20010007-001S
60A	Dust port grating	1	1-JL20010019-001S
61A	Hex cap screw M5x12	3	1-M5X12GB70D1B
62A	Heel stop block	1	1-FDBS2001014001
63A	Stud shaft	1	1-JL26010015
65A	Electric socket	1	1-DB-F-M
66A	Dust board	1	1-JL26030019
67A	Pan head screw M5x10	4	1-M5X10GB818B
68A	Tool holder	1	1-JL26090001
69A	Threading board	1	1-JL26010011-117U
70A	Strain relief M20	2	1-JL91046100B
71A	Hex nut M10	2	1-M10GB6170B
72A	Washer	1	1-WSH10GB849B
73A	Heel block	1	1-JMBS1403030004
74AA	Camshaft handle	1	1-JMBS1801015001A
75A	Knob ball	1	1-1904011
77AA	Cam	1	1-JMBS1401012002
78AA	Tension	1	1-JMBS1403016003A
79A	Hex cap screw M8x12	1	1-M8X12GB70D2B
80A	Big washer	1	1-WSH8GB96B
81A	Plastic tubing	1	1-JXBS2401010018
82A	Set screw M6x30	1	1-M6X30GB77B
83A	Upper blade guard	1	1-JMBS1801010006
84A	Bearing Sleeve	1	1-JMBS1403014002
85A	Ratchet handle	1	1-KTSB-1-B-M8X63X20
86A	Potentiometer knob	1	1-RCWL1601091003
87A	Start button	1	1-LA39-B2-10-g
88A	Stop button	1	1-LA39-B2-R02Z-R
89A	Switch cover	1	1-JMBS180101009A-117U
90A	Cr pan hd screw M3X10	2	1-M3X10GB818Z
91A	Cr apn hd screw M4X6	3	1-M4X6GB818B
92A	Speed measuring plate	1	1-JMBS1801010010
93A	Cable clamp	1	1-1502014-02
94A	Transducer	1	1-ATV12HU15M2

PARTS DIAGRAM

TABLE ASSEMBLY SHEET B

NOTE: Please reference the Manufacturer's Part Number when calling for Replacement Parts.

For Parts under Warranty, the serial number of your machine is required.

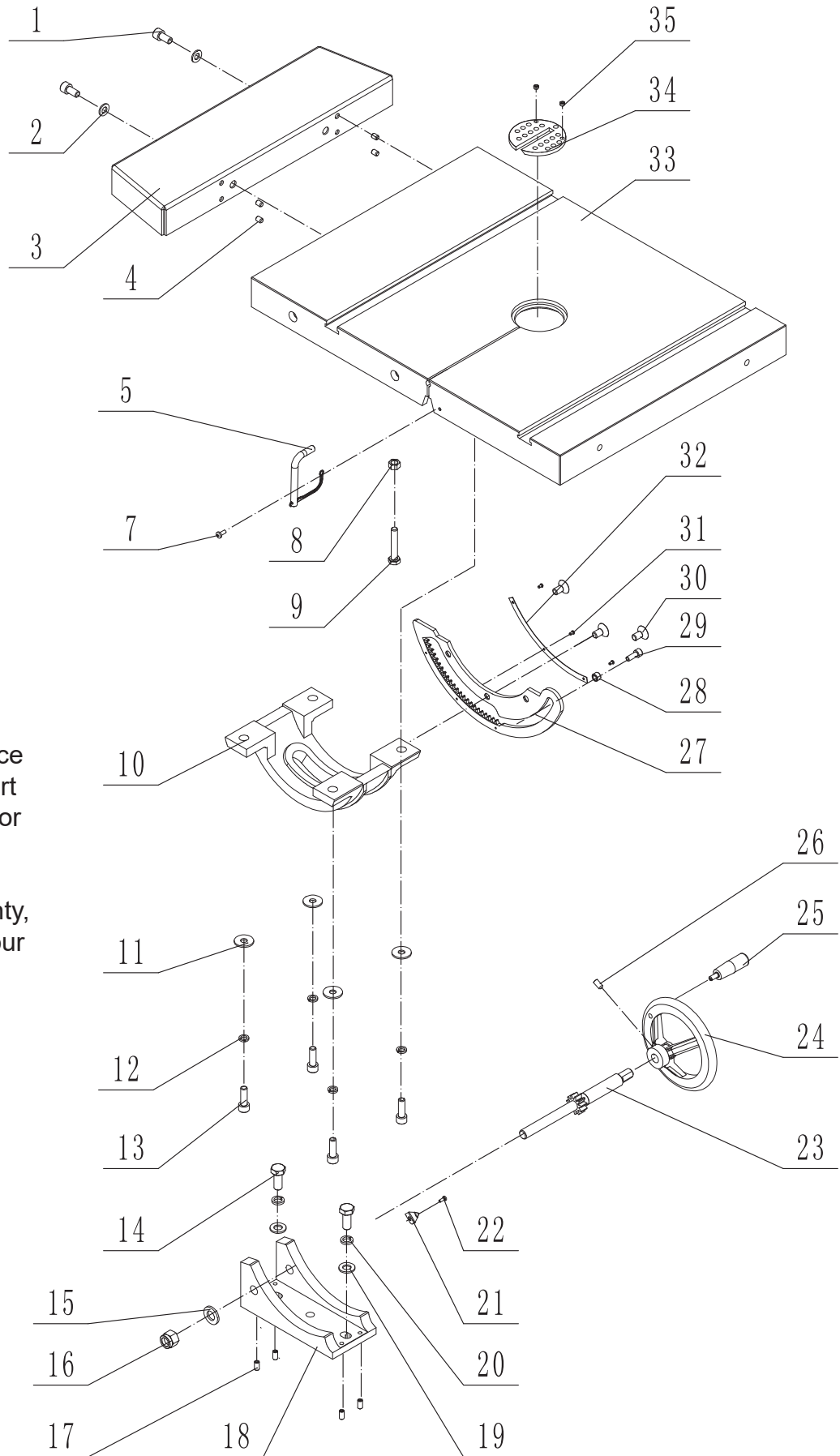

PARTS LIST

TABLE ASSEMBLY - SHEET B

KEY NO.	DESCRIPTION	QTY	MFG. PART NO.
1B	Hex socket cap screw M8x16	2	1-M8X16GB70D1Z
2B	Flat washer M8	2	1-WSH8GB97D1Z
3B	Extension table	1	1-JMBS1801030002-076U
4B	Set screw M6x8	4	1-M6X8GB77B
5B	Table support pin assembly	1	1-JMBS1404030002
7B	Cross recess pan head screw M4x10	1	1-M4X10GB818Z
8B	Nut M8	1	1-M8GB6170B
9B	Hex bolt M8x50	1	1-M8X50GB5781B
10B	Lower table trunnion	1	1-JMBS1403030002
11B	Big washer	4	1-WSH8GB96B
12B	Spring washer	4	1-WSH8GB93B
13B	Hex socket cap screw M8x25	4	1-M8X25GB70D1B
14B	Hex bolt M10x25	2	1-M10X25GB5783B
15B	Flat washer M12	1	1-WSH12GB97D1B
16B	Hex locking nut	1	1-M12GB889B
17B	Set screw M6x12	4	1-M6X12GB77B
18B	Support bracket	1	1-JMBS1403030005
19B	Flat washer	2	1-WSH10GB97D1B
20B	Spring washer	2	1-WSH10GB93B
21B	Table angle pointer	1	1-JXBS2401031008A
22B	Cross recess pan head screw M3x8	1	1-M3X8GB818Z
23B	Gear shaft	1	1-JMBS1403030007A
24B	Handle	1	1-SGSL-D125-d12
25B	Small handle	1	1-JL26020014-001S
26B	Set Screw M6x12	1	1-M6X12GB80B
27B	Rack	1	1-JMBS1403030003
28B	Eccentric bushing	1	1-JMBS1403030008
29B	Screw M6x16	1	1-M6X16GB70D1B
30B	Hex countersunk head screw M8x16	3	1-M8X16GB70D3Z
31B	Rivet	3	1-RVT2D5X5GB827C
32B	Angle scale label	1	1-JMBS1403030006
33B	Table	1	1-JMBS1801030001A-001L
34B	Table insert	1	1-JL26050008A-001S
35B	Set screw M6x4	2	1-M6X4GB77B

PARTS DIAGRAM

GUIDE POST ASSEMBLY

SHEET C

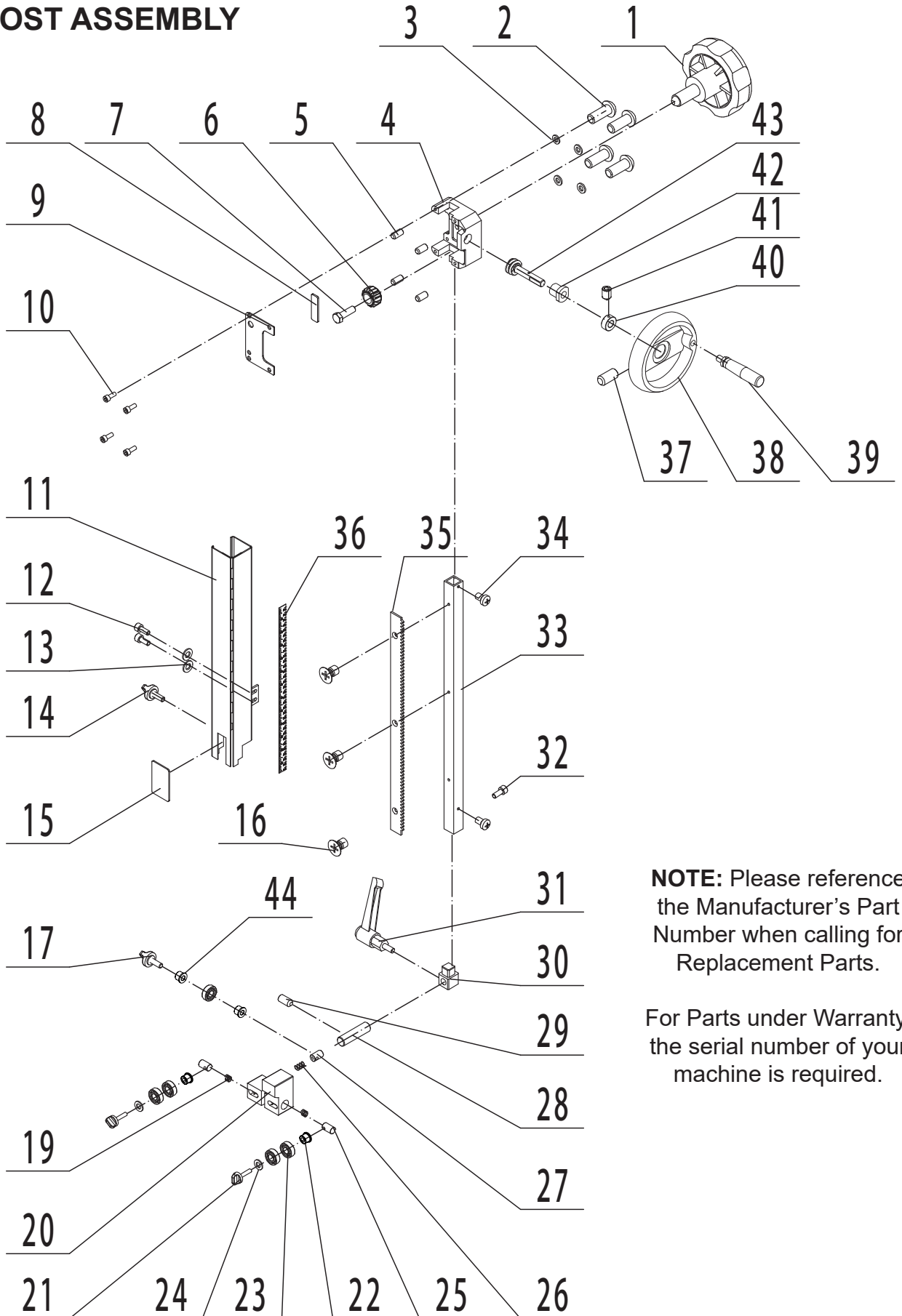

NOTE: Please reference the Manufacturer's Part Number when calling for Replacement Parts.

For Parts under Warranty, the serial number of your machine is required.

PARTS LIST

GUIDE POST ASSEMBLY - SHEET C

KEY NO.	DESCRIPTION	QTY	MFG. PART NO.
1C	Lock handle	1	1-JL26040015-001S
2C	Hex bolt M8x20	4	1-M8X20GB70D2B
3C	Big washer	4	1-WSH8GB96B
4C	Guide bracket	1	1-JL26040008
5C	Set screw M6x12	4	1-M6X12GB77B
6C	Gear	1	1-1501006
7C	Fixed bolt	1	1-JL26040006
8C	Fixed plate	1	1-JL26040007
9C	Guide bracket cover	1	1-BS5001050001
10C	Hex bolt	4	1-M8X16GB70D1B
11C	Hinged door	1	1-JMBS1801051000B-114X
12C	Hex socket cap screw M5x12	2	1-M5X12GB70D1B
13C	Washer	2	1-WSH5GB97D1B
14C	Lock handle	1	1-JMBS1403050004-001S
15C	Clear window	1	1-JMBS1404050001
16C	Screw M4x10	3	1-M4X10GB819B
17C	Lock handle	1	1-JMBS1801052002-001S
19C	Spring	2	1-JMBS1403014005
20C	Upper guide	1	1-JMBS1801052001
21C	Lock handle	2	1-JMBS1801052002-001S
22C	Bearing sleeve	2	1-JMBS1801052003
23C	Bearing	5	1-BRG6202-2RSGB276
24C	Flat washer	2	1-WSH8GB96B
25C	Guide shaft	2	1-JMBS1403014003
26C	Spring	1	1-JMBS1403014008
27C	Adjust bar	1	1-JMBS1801052004
28C	Guide supporting rod	1	1-JL26041004
29C	Locking screw M6x12	1	1-M8X10GB77B
30C	Upper guide support block	1	1-BS5001052001
31C	Ratchet handle	1	1-KTSB-1-B-M8X63X25
32C	Hex socket cap screw M6x30	1	1-M6X30GB70D1B
33C	Slider bar	1	1-BS5001050003
34C	Pan head screw M5x10	2	1-M5X10GB818B
35C	Rack	1	1-BS6001050001
36C	Scale	1	1-JMBS1403050002
37C	Locking screw M6x12	1	1-M6X12GB77B
38C	Crank handwheel	1	1-SGSL-D100-d12
39C	Small handle	1	1-JL26020014B-001S
40C	Set screw collar	1	1-CLP12GB884B
41C	Set screw M5x8	1	1-M5X8GB78B
42C	Bushing	1	1-JL26040003
43C	Worm cylinder	1	1-JL26040004
44C	Bearing sleeve	2	1-JMBS1403014002

PARTS DIAGRAM

BLADE TENSION & TRACKING

SHEET D

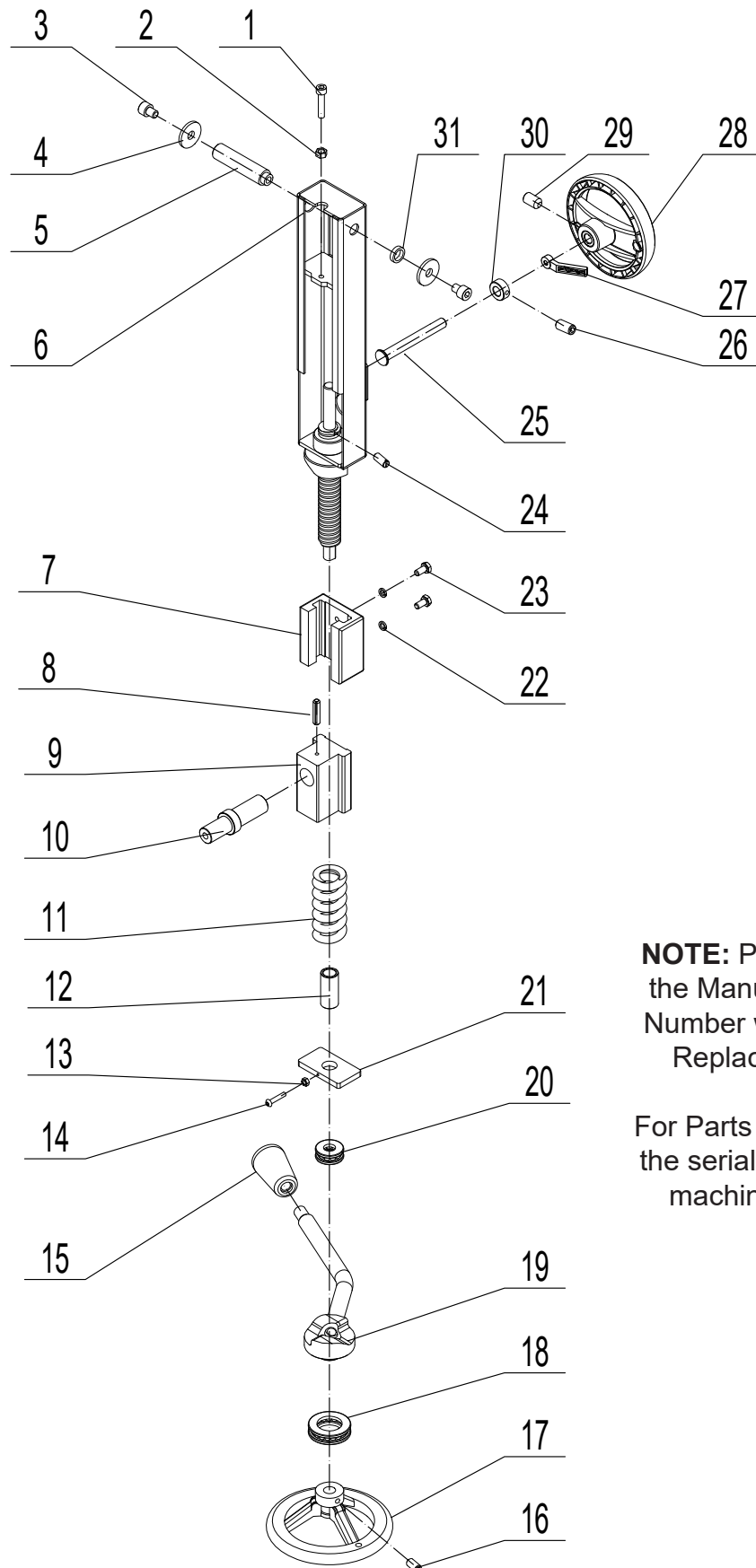

NOTE: Please reference the Manufacturer's Part Number when calling for Replacement Parts.

For Parts under Warranty, the serial number of your machine is required.

PARTS LIST

BLADE TENSION & TRACKING SHEET D

KEY NO.	DESCRIPTION	QTY	MFG. PART NO.
1D	Hex socket cap screw M6x30	1	1-M6X30GB70D1Z
2D	Hex nut M6	1	1-M6GB6170Z
3D	Hex socket cap screw M8x10	2	1-M8X10GB70Z
4D	Washer	2	1-WSH8GB5287Z
5D	Supporting roller	1	1-JL26030001A
6D	Blade tension bracket assembly	1	1-JL26031000B
7D	Sliding Rail	1	1-JL26030013
8D	Roll pin	1	1-PIN5X35GB879D1B
9D	Upper wheel shaft hinge	1	1-JL26030009A
10D	Upper wheel shaft	1	1-JMBS1801040001
11D	Spring	1	1-JL26030011
12D	Spring bushing	1	1-JL26030002
13D	Hex nut	1	1-M3GB6170B
14D	Screw M3x16	1	1-M3X16GB70D2B
15D	Knob ball	1	1-1904011
16D	Set screw M6x12	1	1-M6X12GB80B
17D	Large tension handwheel	1	1-SGSL-D125-D12
18D	Bearing	1	1-BRG51105GB301
19D	Tension lever with riser block	1	1-JL26030018
20D	Bearing	1	1-BRG51201GB301
21D	Layer board	1	1-JMBS1403040007
22D	Washer	2	1-WSH6GB93Z
23D	Hexagon bolt M6x12	2	1-M6X12GB5783Z
24D	Set screw M5x12	1	1-M5X12GB73B
25D	Stud shaft	1	1-JL26030020
26D	Set screw M5x10	1	1-M5X10GB77B
27D	Locking handle	1	1-JL26030016-001S
28D	Top wheel tilt handwheel	1	1-SGSL-D100-d10
29D	Set screw M6x10	1	1-M6X10GB80B
30D	Retainer ring	1	1-JL26030021
31D	Support sleeve	1	1-JL26030017A

NOTE: Please reference the Manufacturer's Part Number when calling for Replacement Parts.
For Parts under Warranty, the serial number of your machine is required.

PARTS DIAGRAM & PARTS LIST

RIP FENCE ASSEMBLY - SHEET E

NOTE: Please reference the Manufacturer's Part Number when calling for Replacement Parts.

For Parts under Warranty, the serial number of your machine is required.

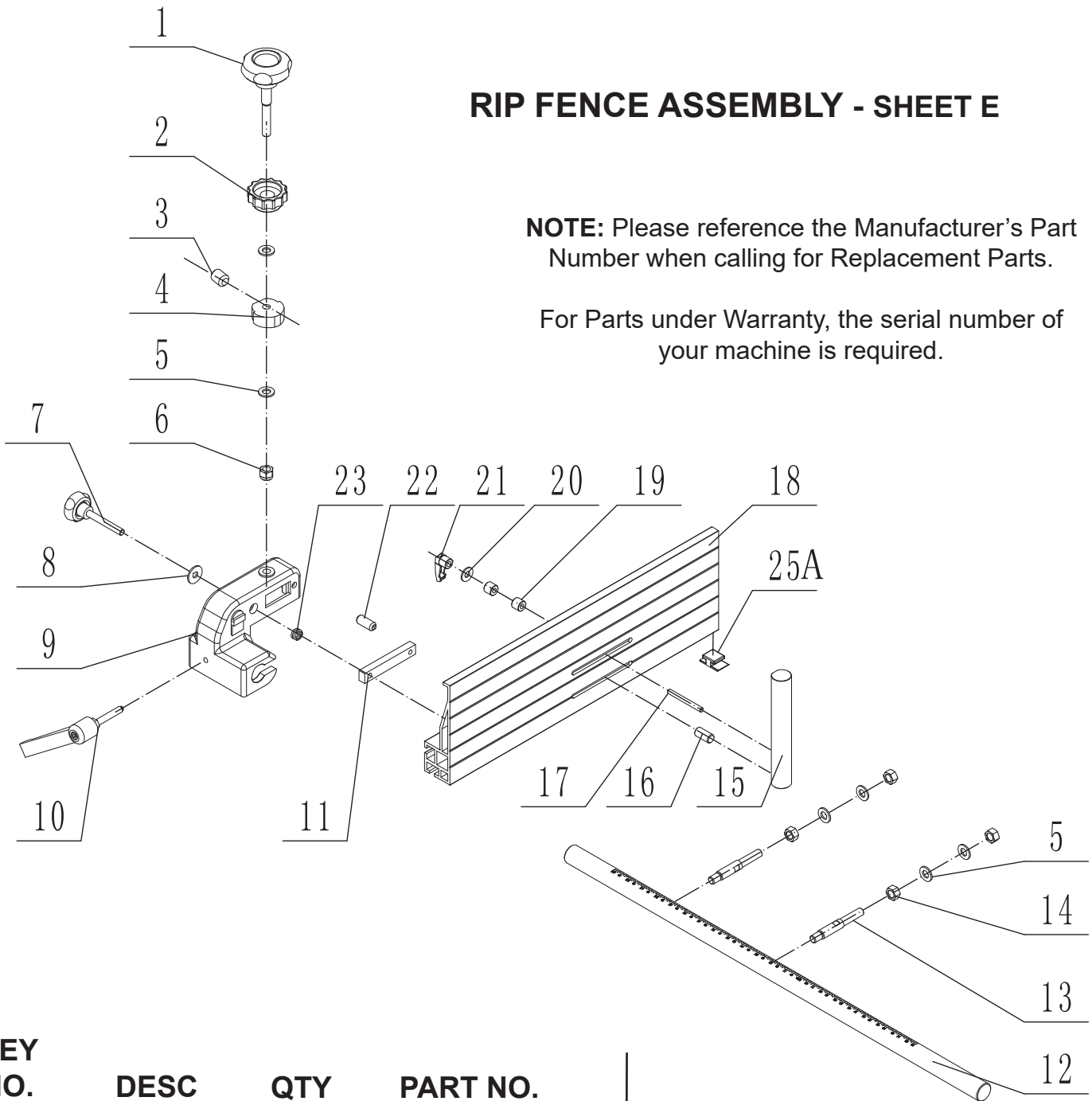

KEY

KEY NO.	DESC	QTY	PART NO.
1E	Adjust handle	1	1-JMBS1403060009-001S
2E	Drift locking handle	1	1-JMBS1403060010-001S
3E	Cap screw M8x10	1	1-M8X10GB80B
4E	Cam	1	1-JMBS1403060004
5E	Flat washer	6	1-WSH10GB97D1Z
6E	Hex locking nut M10	1	1-M10GB889D1Z
7E	Fence locking handle	1	1-JMBS1403060003-001S
8E	Big washer	1	1-WSH8GB96Z
9E	Fence carrier	1	1-JMBS1403060001-076U
10E	Carrier locking handle	1	1-JMBS1403060011
11E	Sliding block	1	1-JMBS1403060005
12E	Guide rail	1	1-JMBS1801060004
13E	Connecting rod	2	1-JXBS2001060003
14E	Hex nut	4	1-M10GB6170Z

KEY

KEY NO.	DESC	QTY	PART NO.
15E	Re-saw bar	1	1-JMBS1403061001
16E	Screw	1	1-JL26061003
17E	Bolt	1	1-JMBS1403061002
18E	Fence	1	1-JMBS1403060002
19E	Spacer	2	1-JL93010018
20E	Washer	1	1-WSH6GB97D1B
21E	Lock knob	1	1-KTSB-1-A-M6X50
22E	Roll pin	1	1-PIN6X26GB879D1B
23E	Spring	1	1-JMBS1403060007
25AE	Nylon plate	1	1-JMBS1401060001A

PARTS DIAGRAM & PARTS LIST

MOTOR & DRIVE WHEEL ASSEMBLY SHEET F

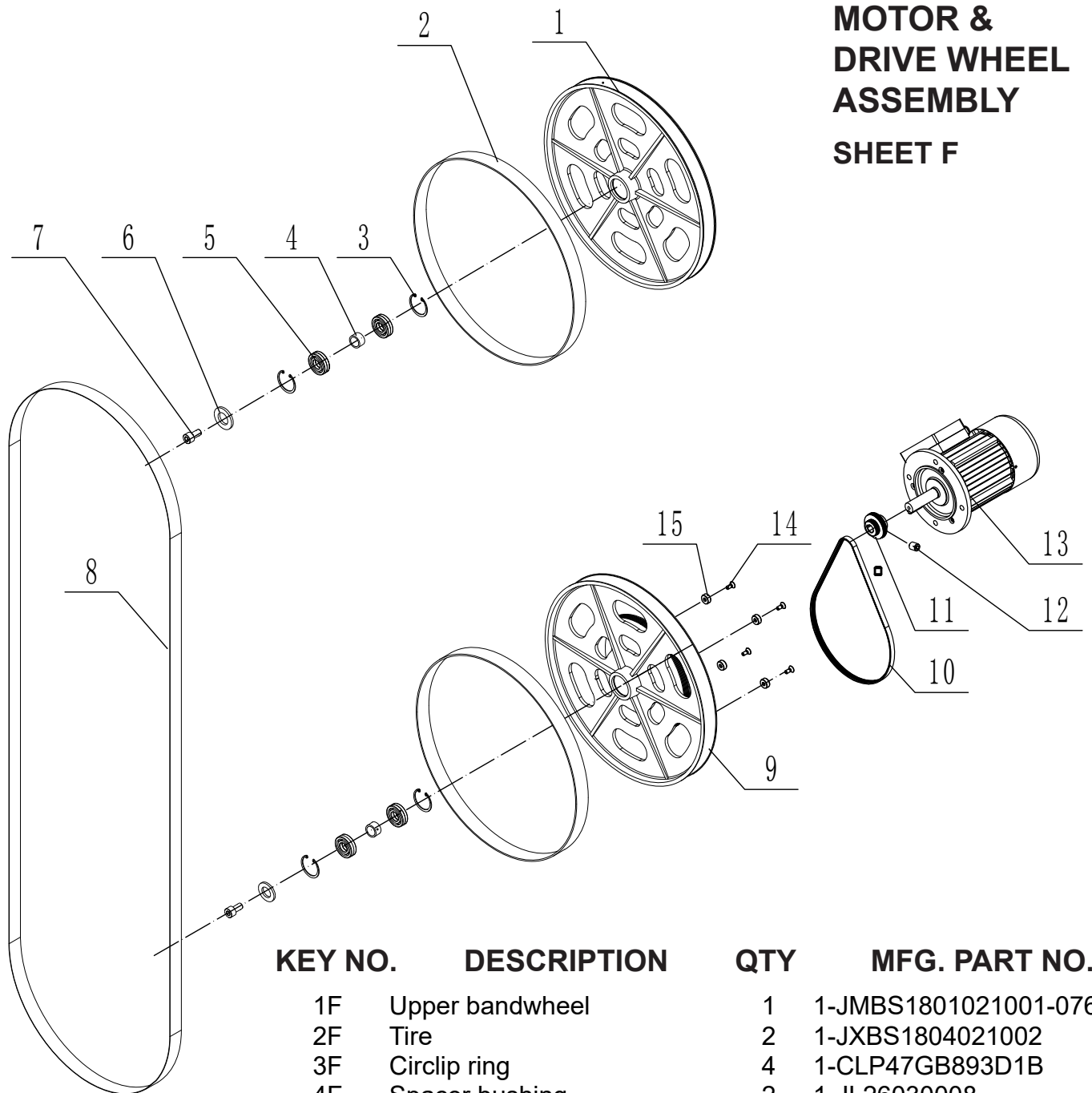

KEY NO.	DESCRIPTION	QTY	MFG. PART NO.
1F	Upper bandwheel	1	1-JMBS1801021001-076Z
2F	Tire	2	1-JXBS1804021002
3F	Circlip ring	4	1-CLP47GB893D1B
4F	Spacer bushing	2	1-JL26030008
5F	Bearing	4	1-BRG6204-2RSGB276
6F	Washer	2	1-JXPS1202070005
7F	Hex screw M8x16	2	1-M8X16GB70D1Z
8F	Bandsaw blade	1	1-JMBS1801020002
9F	Lower bandwheel	1	1-JMBS1801022001-076Z
10F	Multi-vee belt	1	1-5PJ1023GB16588
11F	Motor pulley	1	1-JMBS1801020004D
12F	Socket head cap screw M8X8	2	1-M8X8GB80B
13F	Motor	1	2-YSH100194
14F	Countersunk screw M4X10	4	1-M4X10GB819D1B
15F	Magnetic steel	4	1-JMWL1203010006

NOTE: Please reference the Manufacturer's Part Number when calling for Replacement Parts.

For Parts under Warranty, the serial number of your machine is required.

ACCESSORIES

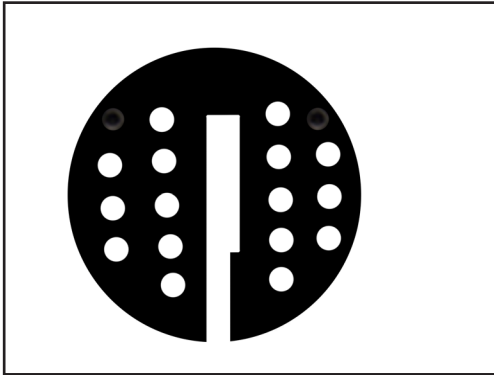

C10-391 TABLE INSERTS - PK 4
Replacement plastic inserts with rear threaded holes for hex screw levellers.

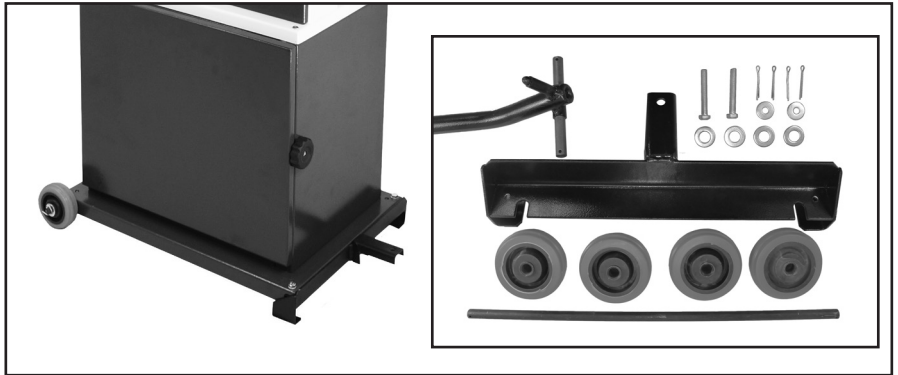

13-345 MOBILITY KIT Conversion Kit installs onto the bandsaw base to make it easy to move around the shop. Includes rear wheel assembly, front support, tow bar, hardware and instructions.



13-912 'T' SLOT MITER GAUGE
Fits 3/4" x 3/8" miter slots. Handy scale for up to 60° left and right angle settings, includes adjustable 9" aluminum fence extension and push handle.

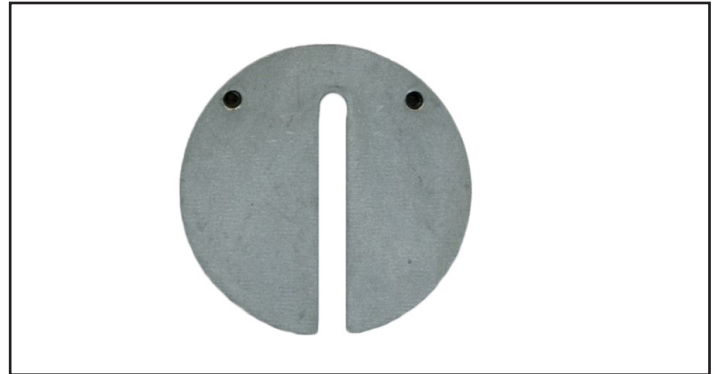

C10-395 ALUMINUM TABLE INSERT
Replacement cast aluminum insert with central slot for positioning the bandsaw blade. Provides solid support and includes rear table levelling screws.



C10-392 ZERO CLEARANCE INSERTS - PK 4
Pack of four plastic inserts with table levelling screws. Inserts have no slot and require user to cut their own on installation. This minimizes the slot width so debris or thin cut wood strips will not catch or fall into the thin slot. Ideal for use when cutting small pieces on the bandsaw for inlay, shims, puzzles, etc.



BAND SAW BLADES
For a complete line of 142" band saw blades, contact your local RIKON Distributor, or visit the RIKON website at www.rikontools.com.

LINK TO RIKON WEBSITE



WARRANTY

RIKON

POWER TOOLS®

5-Year Limited Warranty

RIKON Power Tools Inc. ("Seller") warrants to only the original retail consumer/purchaser of our products that each product be free from defects in materials and workmanship for a period of five (5) years from the date the product was purchased at retail. This warranty may not be transferred.

This warranty does not apply to defects due directly or indirectly to misuse, abuse, negligence, accidents, repairs, alterations, lack of maintenance or normal wear and tear. Under no circumstances will Seller be liable for incidental or consequential damages resulting from defective products. All other warranties, expressed or implied, whether of merchantability, fitness for purpose, or otherwise are expressly disclaimed by Seller. This five-year warranty does not cover products used for commercial, industrial or educational purposes. The warranty term for these claims will be limited to a two-year period.

This limited warranty does not apply to accessory items such as blades, drill bits, sanding discs, grinding wheels, belts, guide bearings and other related items.

Seller shall in no event be liable for death, injuries to persons or property, or for incidental, contingent, special, or consequential damages arising from the use of our products.

To take advantage of this warranty, proof of purchase documentation must be provided which has the date of purchase and an explanation of the complaint.

The Seller reserves the right to effect at any time, without prior notice, those alterations to parts, fittings, and accessory equipment which they may deem necessary for any reason whatsoever.

To register your machine online, visit RIKON at www.rikontools.com/warranty

**To take advantage of this warranty, or if you have any questions,
please contact us at 877-884-5167 or email warranty@rikontools.com**



For more information:
25 Commerce Way
North Andover, MA 01845

877-884-5167 / 978-528-5380
techsupport@rikontools.com

LINK TO RIKON WEBSITE

